





# 6 Wiring Adaptor for Remote Control KRP413A1S

## Safety Precautions

- Read these safety precautions carefully before installing the unit, and be sure to install the unit properly.
- This manual classifies precautions to the user into the following two categories. These warnings and cautions are for your safety. Follow them.

 <b>WARNING</b>	Faulty installation can result in death or serious injury.
 <b>CAUTION</b>	Faulty installation can result in serious injury, damage to property, or other serious consequences.

- Below is a key to symbols used in this manual.

	Be sure to follow instructions.
	Be sure to perform grounding work.
	Never attempt.

- After installation is complete, test the unit to confirm that it is working properly, and instruct the owner its proper use.

### WARNING

- Installation should be left to the dealer from whom you purchased the unit, or another qualified professionals.
- Install the unit securely according to the installation manual. Faulty installation may lead to electric shock or fire.
- Be sure to use the supplied or specified parts. Using other parts may lead to electric shock or fire.
- Install the unit securely in a location that will support its weight. If installed in a poor location or improperly installed, the unit may not work as intended.
- For electrical work, follow local electric standards and the installation manual. Faulty installation may lead to fire or electric shock.
- Do not bundle the power cord, or attempt to extend it by splicing it with another cord or by using an extension cord. Do not place any other load on the power circuit used for the unit. Improper wiring may lead to electric shock, heat generation or fire.
- Use dedicated wiring for all electrical connections, and be sure to arrange the wiring so that force applied to the wiring will not damage the terminals. Poor wiring or installation may cause electric shock, heat generation or fire.

### CAUTION

- Before installation, unplug the air conditioner to ensure safety. Failure to do so may cause electric shock.
- Static electricity may damage electric components. Before connecting cables and communication lines, and operating the switches, be sure to discharge any electrical charge from your body (by, for example, touching the earth line)
- Do not install the unit in a location where it may be exposed to flammable gases. If gas leaks and build up around the unit, it may catch fire.
- Do not place the relay harness close to the power cord, inter-unit cable, or pipes which generate noise. Treat the harness with care.

## 1. Functions and Features

- On/Off setting
- Switching between Instantaneous Contact/Normal Contact
- Connection with five-room central controller (KRC72 for oversea model)
- Connection with fan coil remote controller
- Automatic reset after power failure
- Output of normal operation signals/alert signals

## 2. Field Wiring

For interconnecting wiring, use Daikin KDC100A12 cable (not supplied) or other similar cable. The cable should have the specifications shown below.

### ■ Optional cable KDC100A12 (without connectors)

Specifications:	0.2 mm <sup>2</sup> × 4 core (sheathed)
Outer diameter:	φ5.3
Length:	100 m
Colour:	Grey

### ■ Other cable (commercially available)

Item	Outer dia.	Remarks
Cable for instrumentation (IPVV) 0.3 mm <sup>2</sup> × 4-core	7.2 mm	Hard sheath
Microphone cord (MVVS) 0.3 mm <sup>2</sup> × 4-core	8.0 mm	Shielded
Microphone cord (MVVS) 0.2 mm <sup>2</sup> × 4-core	6.5 mm	
Microphone cord (MVVS) 0.15 mm <sup>2</sup> × 4-core	4.8 mm	
Intercom cable 0.65 mm <sup>2</sup> dia. × 4-core		
PVC jumper wire (TJVC) (from 0.5 mm dia. × 4 pcs.)	—	Not sheathed

Note 1: Keep any wiring for the control unit away from the power cord to prevent electrical noise.

Note 2: Do not use cables shown above for power cord, inter-unit cord/cable or power cord for lamps.

# Installation

This product is available in two types. The **KRP413A1S** is for installation in a case independent of the indoor unit, and the **KRP413A1** is for installation within the indoor unit.

## 1. KRP413A1S

### 1 Installation diagram

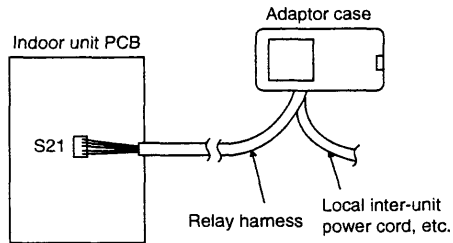

### 2 Components

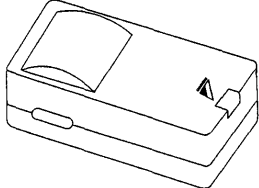
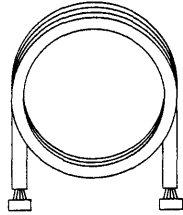
<p>① Adaptor case assy (Adaptor (PCB) is attached in the adaptor case.)</p> 	<p>② Relay harness (approx. 0.8 m)</p> 
<p>③ Accessories</p> <ul style="list-style-type: none"> <li>• Tie-wrap (4 pcs.)</li> <li>• Velcro for attaching to the indoor unit (2 sets)</li> <li>• Screws for attaching the adaptor case (4 pcs.)</li> <li>• Screws for attaching to the wall (3 pcs.)</li> </ul>	
<p>④ Installation manual</p>	

## 2. KRP413A1

For this type, install the adaptor PCB within the indoor unit. The method of installation and connection vary depending on the model of the air conditioner. See your air conditioner installation manual for details.

### 1 Components

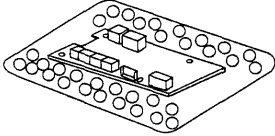
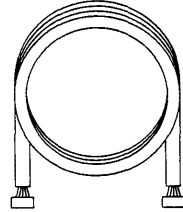
<p>① Adaptor PCB</p> 	<p>② Relay harness (approx. 0.8 m)</p> 
<p>③ Installation manual</p>	

## 3. Attaching Adaptor Case Assy (for KRP413A1S)

### 1 Using the screws (to mount on a wall, etc.)

- Use the 3 supplied screws to attach the case assy.

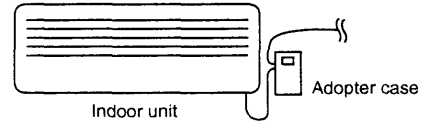

Install the adaptor case assy as close to the indoor unit as possible.

#### ① Removing case front

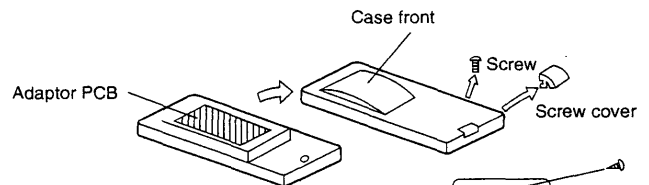

Remove the screw cover, one of the screws and then the case front.

#### ② Attach the case back to the surface by tightening the screws through the screw holes (one round hole, two long holes).

#### ③ After connecting the cables (refer to the following sections), replace the case front. Be careful not to damage the harness in the case.

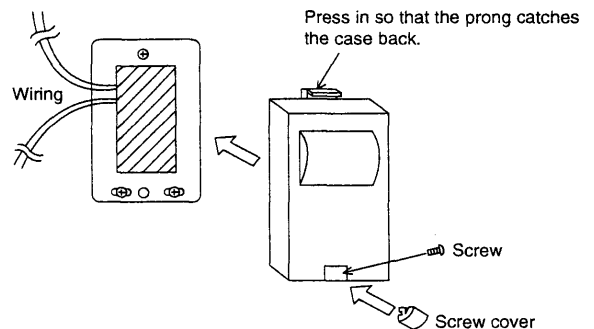

### 2 Using Velcro (to attach on the indoor unit)

- Attach the adaptor case with the supplied Velcro.
- ① Remove the case front (as for mounting on a wall).
- ② After connecting the cables (see the following sections), replace the case front. It can be screwed to the case back from the rear with the four supplied screws. Be careful not to damage the harness in the case.
- ③ Stick one end of the Velcro to the rear side of the case back, and stick the other end to the indoor unit with the same space between them.

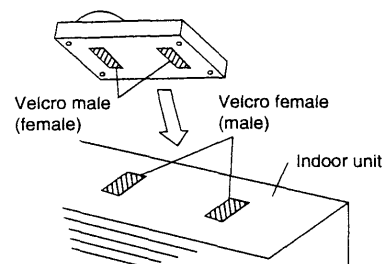

To prevent the adaptor case assy from falling, do not use the Velcro for attaching it to a wall or other surface.

# Wiring

## 1. Wiring

- ① Connect one end of the relay harness to connector S21 of the PCB in the indoor unit.
- ② Connect the other end of the relay harness to connector S6 of the adaptor PCB.
- ③ Connect field wiring according to the functions assigned to each connection terminal of the adaptor PCB.
- ④ Secure all wires.

### 1 Securing wires in the adaptor case assy (for KRP413A1S)

- Fasten with a tie-wrap so that wires will not come loose even if pulled.

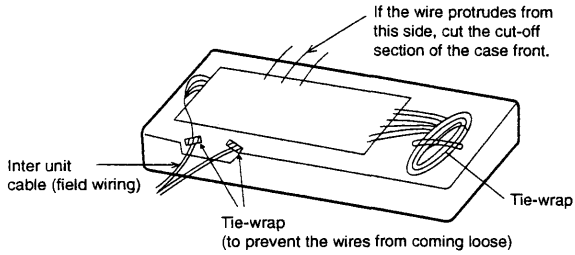

### 2 Securing wires in the indoor unit (for KRP413A1)

- The method for securing wire varies depending on the model of the air conditioner. See your air conditioner installation manual for details.

## 2. Automatic Reset After Power Failure

- This PCB stores the following data in the event of a power failure (common features).
  - ① On/Off (see Note 1)
  - ② Operation modes
  - ③ Temperature setting
  - ④ Air flow rate
  - ⑤ On/Off status of remote controller
 (Note 1 When SW1-2 is in Off mode, the unit will not be activated.)

## 3. Monitor Signal Output (normal operation and alerts)

- Maximum length of the wiring is 100 m.

### 1 Monitor signal output for LED

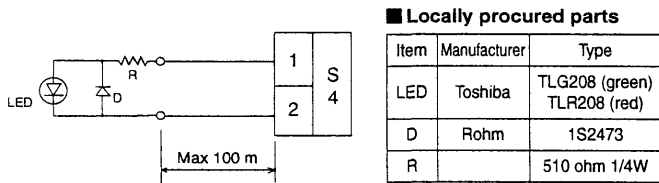

### 2 Monitor signal output (normal operation and alerts) using external relay contacts

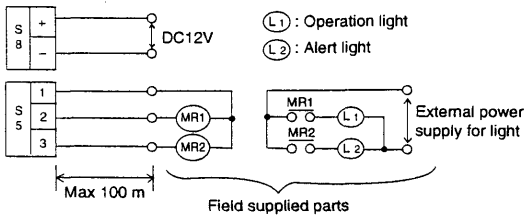

#### Field procured parts (Recommended external relay contacts)

Manufacturer	Type	Coil rated voltage	Coil resistance
Omron	MY relay	12 V DC	160 ohm ± 10%
Matsushita	HC relay	12 V DC	160 ohm ± 10%

## 4. Connection with Remote Controller

Example connections with three kinds of remote controllers are shown below.

Note: These connections cannot be used in combination.

### 1 Generic remote controller

- Set SW1-1 to Off and select Operation Mode 1.

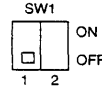

#### <Instantaneous Contact>

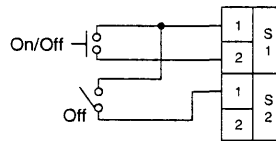

- The remote controller most recently used (local or air conditioner) takes precedence.
- Use a remote controller with a pulse width of 100 m/sec or more.

#### <Normal Contact>

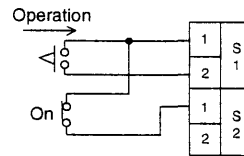

- Power On/Off cannot be controlled from the unit's remote controller.
- When power is restored after a power failure in this mode, On or Off is determined according to the current settings of the remote controller.

### 2 Five-room central controller (KRC72)

- Set SW1-1 to Off and select Operation Mode 1.
- The remote controller most recently used takes precedence.

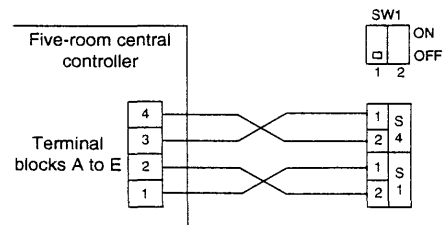

### 3 Fan coil remote controller

- Set SW1-1 to On and select Operation Mode 2.
- Most settings (power On/Off, air flow rate, mode change) cannot be made using the air conditioner's remote controller.
- When power is restored after a power failure in this mode, On or Off is determined according to the current settings of the remote controller.
- When the Cooling /Heating mode is changed, use the air conditioner's remote controller to adjust the temperature.

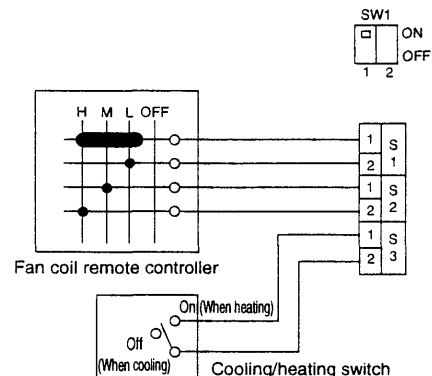

# Test Operation and Confirmation

## 1. When the System is Not Working

- Is the air conditioner working properly?
- Are the connectors of the relay harness properly connected?
- Are the remote controller and field wiring properly connected?
- Are all switch settings correct?
- If there is nothing apparently wrong, conduct a diagnostic check using the following procedure.

### Diagnostic check

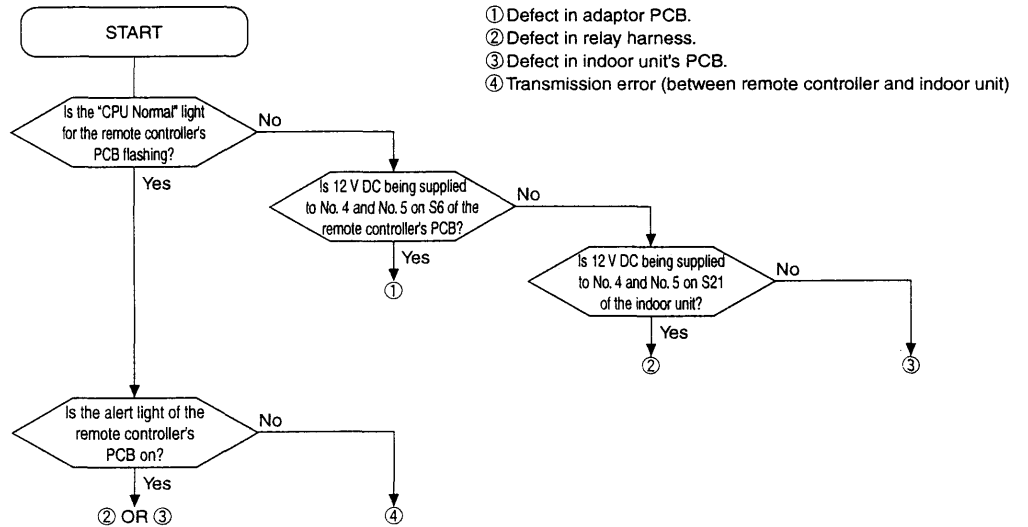

## 2. Switch Settings and Connection Terminals

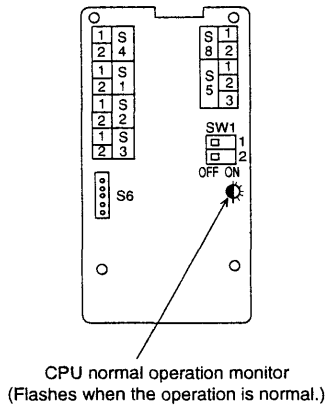

SW1-1	Selecting the operation mode	OFF	Operation mode 1 (Used with the exception of fan coil remote controller settings)	
		ON	Operation mode 2 (Used with fan coil remote controller settings)	
SW1-2	Selecting On/Off when power is restored after a power failure	OFF	Always Off	
		ON	Off if operation was in Off mode before power failure; On if operation was in On mode before power failure	
S1 S2 S3	SW1-1: OFF (Operation mode 1)		Instantaneous contact	Normal contact
		S1 (1) - S2 (1)	OPEN	CLOSE
		S1 (1) - S1 (2)	Pulse input On/Off switching	OPEN, Not activated
	S2 (2), S3	CLOSE, Activated		
			Not used	
	SW1-1: ON (Operation mode 2)	S1, S2 OPEN	Not activated	
		S1 (1) - S1 (2) CLOSE	On, airflow: L tap	
S1 (1) - S2 (1) CLOSE		On, airflow: M tap		
S1 (1) - S2 (2) CLOSE		On, airflow: H tap		
S3 (With the remote controller only)		OPEN, Cooling		
		CLOSE, Heating		
S4	(1) - (2)	Voltage on (DC12 V), normal operation light output		
S5	(1) - (2)	Normal operation light output (power for light required)		
	(1) - (3)	Alert light output (power for light required)		
S6 connector		Connect with connector S21 on the PCB of the indoor unit		
S8	(+) - (-)	Relay DC 12 V power supply terminal		