

TABLE OF CONTENTS

RMXS-E8V1B

1	Features	814
2	Specifications	815
	Nominal Capacity and Nominal Input	815
	Technical Specifications	815
	Electrical Specifications	817
3	Electrical data	818
4	Options	819
5	Capacity tables	820
	Cooling capacity tables	820
	Heating capacity tables	826
	Capacity correction factor	832
6	Dimensional drawing & centre of gravity	834
	Dimensional drawing	834
	Centre of gravity	835
7	Piping diagram	836
8	Wiring diagram	837
	Wiring diagram	837
	External connection diagram	838
9	Sound data	839
	Sound pressure spectrum	839
	Sound power spectrum	841
10	Installation	842
	Installation method	842
11	Operation range	844

1 Features

- The RMXS gives you a high-capacity multi split system which combines the power and easy installation of a VRV outdoor unit with the quiet operation of residential - use indoor units.
- The Super Multi Plus has more than enough power to drive up to 9 indoor units, including a 7,1 kW class unit.
- An inverter driven compressor allows the capacity to be adjusted precisely to match variations in room and outside temperatures.
- A 135-meter piping length means there are now no restrictions on the choice of installation position for indoor units, greatly improving planning flexibility.



35

1

2 Specifications

2-1 NOMINAL CAPACITY AND NOMINAL INPUT				RMXS112E8V1B	RMXS140E8V1B	RMXS160E8V1B
Nominal Capacity	Cooling capacity	Standard	kW	11.2	14.0	15.5
	Heating capacity	Standard	kW	12.5	16.0	17.5
For combination indoor units + outdoor units	EER	Nominal		3.20	2.75	2.87
	COP	Nominal		3.18	3.07	3.22
Max. number of connectable indoor units (BP to be connected)				6	8	9
Min. / Max. total capacity index of I/U to be connected				55/145.5	70/182	80/108

2-2 TECHNICAL SPECIFICATIONS				RMXS112E8V1B	RMXS140E8V1B	RMXS160E8V1B	
Casing	Colour			Daikin White			
	Material			Paintable galvanized steel plate			
Dimensions	Unit	Height	mm	1,345			
		Width	mm	900	900	900	
		Depth	mm	320	320	320	
	Packing	Height	mm	1,524			
		Width	mm	980	980	980	
		Depth	mm	420	420	420	
Weight	Unit		kg	120	120	120	
	Packed Unit		kg	130	130	130	
Heat Exchanger	Dimensions	Length	mm	857	857	857	
		Nr of Rows			2	2	2
		Fin Pitch	mm	2	2	2	
		Nr of Passes			10	10	10
		Face Area	m ²	1,131			
		Nr of Stages			60	60	60
	Tube type			Hi-XSS(8)			
	Fin	Type		Non-symmetric waffle louvre			
		Treatment		Corrosion resistant			
	Fan	Type			Propeller		
Discharge direction			Horizontal				
Quantity			2	2	2		
Air Flow Rate (nominal at 230V)		Cooling	m ³ /min	106	106	106	
		Heating	m ³ /min	102	105	105	
Motor		Quantity			2	2	2
	Model			Brushless DC motor			
Motor	Speed (nominal)	Cooling	rpm	850/815			
		Heating	rpm	820/785	840/805	840/805	
Fan	Motor	Output	W	70	70	70	
		Drive			Direct Drive		
Compressor	Quantity			1	1	1	
	Motor	Model			JT100G-VDL@T2		
		Type			Hermetically sealed scroll compressor		
		Speed	rpm	6,480			
		Motor Output	W	2.5	3.0	3.5	
		Crankcase Heater	W	33	33	33	
		Starting Method			Direct on line		
Operation Range	Cooling	Min	°CDB	-5	-5	-5	
		Max	°CDB	46	46	46	
	Heating	Min	°CWB	-15	-15	-15	
		Max	°CWB	20	20	20	
Sound Level (nominal)	Cooling	Sound Power	dBA	67	68	70	
		Sound Pressure	dBA	51	52	54	
	Heating	Sound Pressure	dBA	53	54	55	
Sound Level (Night quiet)	Sound Pressure		dBA	Step 1: 47Step 2: 44Step 3: 41			

2 Specifications

2-2 TECHNICAL SPECIFICATIONS				RMXS112E8V1B	RMXS140E8V1B	RMXS160E8V1B
Refrigerant	Type			R-410A		
	Charge	kg		4.0	4.0	4.0
	Control			Expansion valve (electronic type)		
	Nr of Circuits			1	1	1
Refrigerant Oil	Type			Daphne FVC68D		
	Charged Volume	l		1.5	1.5	1.5
Piping connections	Liquid (OD)	Quantity		1	1	1
		Type		Flare connection		
		Diameter (OD)	mm	9.52	9.52	9.52
	Gas	Quantity		1	1	1
		Type		Brazed connection		
		Diameter (OD)	mm	19.1	19.1	19.1
	Drain	Quantity		3	3	3
		Type		Hole		
		Diameter (OD)	mm	26x3		
	Piping Length	System total	m	115	135	145
Piping Length	Total	OU - BP	m	55	55	55
		BP - IU	m	60	80	90
	1 room	BP - IU	m	15	15	15
Piping connections	Height difference	OU - BP	m	30	30	30
		OU - IU	m	30	30	30
		BP-BP/IU-IU	m	15	15	15
	Additional Refrigerant Charge		kg/m	Refer to installation manual		
	Installation height difference	Maximum	m	30	30	30
	Max. internunit level difference		m	15	15	15
	Heat Insulation			Both liquid and gas pipes		
Defrost Method				Reversed cycle		
Defrost Control				Sensor for outdoor heat exchanger temperature		
Capacity Control Method				Inverter controlled		
Capacity control	Cooling	Minimum		24	24	24
		Maximum		100	100	100
	Heating	Minimum		24	24	24
		Maximum		100	100	100
Safety Devices				High pressure switch		
				Fan motor thermal protector		
				Inverter overload protector		
				PC board fuse		
Standard Accessories	Item			Gas connection pipe		
	Quantity			3	3	3
	Item			Installation manual		
	Quantity			1	1	1
	Item			Operation manual		
	Quantity			1	1	1
	Item			Drain socket		
	Quantity			1	1	1
	Item			Drain cap		
	Quantity			2	2	2
	Item			Drain receiver		
	Quantity			3	3	3
	Item			Insulation		
	Quantity			1	1	1

2 Specifications

2-2 TECHNICAL SPECIFICATIONS	RMXS112E8V1B	RMXS140E8V1B	RMXS160E8V1B
Notes	* Nominal cooling capacities are based on : indoor temperature : 27°CDB, 19°CWB, outdoor temperature : 35°CDB, equivalent piping length: outdoor - BP: 5m / BP - indoor: 3m / level difference: 0m.		
	* Nominal heating capacities are based on : indoor temperature : 20°CDB, outdoor temperature : 7°CDB, 6°CWB, equivalent piping length: outdoor - BP: 5m / BP - indoor: 3m / level difference: 0m.		
	The sound power level is an absolute value indicating the power which a sound source generates.		
	Sound pressure level is a relative value, depending on the distance and acoustic environment. For more details, please refer to sound level drawings of this chapter.		
Sound values are measured in a semi-anechoic room.			

2-3 ELECTRICAL SPECIFICATIONS				RMXS112E8V1B	RMXS140E8V1B	RMXS160E8V1B
Power Supply	Name			V1		
	Phase			1N-		
	Frequency		Hz	50	50	50
	Voltage		V	220-240		
	Voltage range	Minimum	V	-10%		
		Maximum	V	+10%		
Current	Nominal running current (RLA)	Cooling	A	15.9	20.2	22.2
		Starting current (MSC)	A	15.9	20.2	22.2
	Min. circuit amp (MCA)		A	27.0	27.0	27.0
	Max. fuse amps (MFA)		A	32.0	32.0	32.0
	Full load amps (FLA)		A	0.3+0.3(Fan motor)		
Wiring connections	For Power Supply	Quantity		3	3	3
		Remark		(including earth wiring)		
	For connection with indoor	Quantity		2	2	2
		Remark		F1+F2		
Power Supply Intake				Both BP unit and outdoor unit		
Notes	RLA is based on following conditions: indoor temperature: 27°CDB/19°CWB, outdoor temperature: 35°CDB					
	Voltage range: units are suitable for use on electrical systems where voltage supplied to unit terminal is not below or above listed range limits					
	Maximum allowable voltage range variation between phases is 2%.					
	Select wire size based on the value of MCA					
	Instead of fuse, use circuit breaker. MFA is used to select circuit breaker and the ground fault circuit interrupter (earth leakage circuit breaker).					
MSC means the maximum current during start up of the compressor						

3 Electrical data

		RMXS112EV	RMXS140EV	RMXS160EV	
Power supply	Name	V1			
	Phase	1N~			
	Frequency	50			
	Voltage	220-240			
Current	Nominal running current (RLA)	A	15.9	20.2	22.2
	Starting current (MSC)	A	15.9	20.2	22.2
	Min. Circuit Amps (MCA)	A	27.0		
	Max. Fuse Amps (MFA)	A	32.0		
	Full Load Amps (FLA)	A	0.3 + 0.3 (Fan motor)		
Voltage range	Min.	V	198		
	Max.	V	264		
Wiring connections	For power supply	Quantity	3		
		Remark	Earth wire included		
	For connection with BP	Quantity	2		
		Remark	F1+F2		
Power supply intake		Both BP unit and outdoor unit			

3TW30401-2

SYMBOLS

- MCA : Min. Circuit Amps
- MFA : Max. Fuse Amps (see note 5)
- RLA : Rated Load Amps (A)
- FLA : Full Load Amps
- MSC : Starting current (see note 6)

NOTES

- 1 RLA is based on the following conditions:
Indoor temperature 27°CDB/19°CWB
Outdoor temperature 35°CDB
- 2 Voltage range
Units are suitable for use on electrical systems where voltage supplied to unit terminals is not below or above listed operation range limits
- 3 Maximum allowable voltage variation between phases is 2%
- 4 Select wire size based on the larger value of MCA
- 5 Instead of fuse, use circuit breaker MFA is used to select the circuit breaker and the ground fault circuit interrupter (earth leakage circuit breaker).
- 6 MSC means the maximum current during start up of the compressor.
- 7 For more details concerning conditional connections, see <http://extranet.daikineurope.com>, select "E-Data Books". Finally, click on the document title of your choice.

4 Options

RMXS-EV				
N°	Item	RMXS112	RMXS140	RMXS160
1	Drain plug		KKPJ5F180	
2	Refnet joint		KHRQ22M20TA	
3	Branch provider (2 rooms)		BPMKS967B2	
4	Branch provider (3 rooms)		BPMKS967B3	
*Note: all options are kits				4TW26791-2B

5 Capacity tables

5 - 1 Cooling capacity tables

RMXS112EV- Cooling capacity													
Combination %	Outdoor air temp. °CDB	Indoor air temp.: °CWB											
		14 °C		16 °C		18 °C		19 °C		22 °C		24 °C	
		TC kW	PI kW	TC kW	PI kW	TC kW	PI kW	TC kW	PI kW	TC kW	PI kW	TC kW	PI kW
130%	10	12.61	2.23	13.99	2.22	15.02	2.21	15.54	2.21	17.16	2.20	18.27	2.20
	14	12.38	2.39	13.72	2.39	14.71	2.40	15.22	2.40	16.79	2.40	17.86	2.40
	18	12.12	2.59	13.41	2.60	14.37	2.61	14.87	2.61	16.39	2.63	17.44	2.64
	20	11.98	2.69	13.25	2.71	14.19	2.72	14.68	2.73	16.18	2.75	17.21	2.76
	23	11.76	2.87	12.99	2.89	13.91	2.91	14.39	2.92	15.85	2.95	16.86	2.97
	27	11.44	3.12	12.63	3.15	13.52	3.18	13.98	3.19	15.39	3.23	16.36	3.26
	31	11.09	3.41	12.23	3.45	13.09	3.48	13.54	3.49	14.90	3.54	15.84	3.58
	35	10.72	3.72	11.81	3.77	12.64	3.80	13.06	3.82	14.38	3.88	15.28	3.92
	39	10.31	4.06	11.35	4.11	12.15	4.16	12.56	4.18	13.83	4.25	14.70	4.29
	43	9.88	4.42	10.87	4.49	11.63	4.54	12.03	4.56	13.25	4.64	14.08	4.69
46	9.04	4.33	9.87	4.33	10.50	4.33	10.83	4.33	11.83	4.33	12.51	4.33	
120%	10	12.46	2.17	13.79	2.16	14.82	2.15	15.33	2.15	16.94	2.14	18.05	2.13
	14	12.23	2.33	13.51	2.33	14.50	2.33	15.01	2.33	16.57	2.34	17.64	2.34
	18	11.97	2.52	13.20	2.53	14.17	2.54	14.66	2.55	16.17	2.56	17.21	2.57
	20	11.83	2.63	13.04	2.64	13.99	2.66	14.47	2.66	15.96	2.68	16.98	2.70
	23	11.61	2.80	12.78	2.82	13.71	2.84	14.18	2.85	15.63	2.88	16.63	2.90
	27	11.29	3.06	12.42	3.09	13.31	3.11	13.77	3.12	15.17	3.16	16.14	3.19
	31	10.94	3.34	12.03	3.37	12.89	3.40	13.33	3.42	14.68	3.47	15.62	3.50
	35	10.57	3.64	11.61	3.69	12.44	3.73	12.86	3.74	14.17	3.80	15.06	3.84
	39	10.17	3.98	11.16	4.03	11.96	4.07	12.36	4.10	13.62	4.16	14.49	4.21
	43	9.74	4.34	10.68	4.40	11.44	4.45	11.83	4.47	13.04	4.55	13.87	4.60
46	8.92	4.33	9.74	4.33	10.37	4.33	10.69	4.33	11.68	4.33	12.36	4.33	
110%	10	11.86	2.04	13.14	2.03	14.14	2.02	14.64	2.02	16.21	2.01	17.29	2.00
	14	11.64	2.20	12.88	2.20	13.85	2.20	14.34	2.20	15.86	2.20	16.90	2.20
	18	11.40	2.39	12.60	2.40	13.53	2.40	14.01	2.41	15.48	2.42	16.50	2.42
	20	11.27	2.49	12.44	2.50	13.37	2.51	13.83	2.52	15.28	2.53	16.28	2.54
	23	11.06	2.66	12.20	2.68	13.11	2.69	13.56	2.70	14.98	2.72	15.95	2.74
	27	10.76	2.90	11.86	2.93	12.73	2.95	13.17	2.96	14.54	2.99	15.49	3.02
	31	10.44	3.18	11.50	3.21	12.34	3.24	12.76	3.25	14.08	3.29	14.99	3.32
	35	10.09	3.47	11.10	3.51	11.91	3.55	12.32	3.56	13.60	3.61	14.47	3.65
	39	9.71	3.80	10.68	3.85	11.46	3.88	11.85	3.90	13.08	3.96	13.93	4.00
	43	9.31	4.15	10.23	4.20	10.98	4.24	11.36	4.27	12.53	4.33	13.35	4.38
46	8.81	4.33	9.62	4.33	10.24	4.33	10.56	4.33	11.54	4.33	12.20	4.33	
100%	10	10.54	1.81	11.79	1.80	12.71	1.79	13.18	1.78	14.64	1.77	15.64	1.75
	14	10.36	1.96	11.57	1.95	12.47	1.95	12.93	1.95	14.34	1.94	15.31	1.94
	18	10.16	2.13	11.33	2.13	12.20	2.13	12.65	2.13	14.02	2.14	14.96	2.14
	20	10.06	2.22	11.21	2.23	12.06	2.24	12.50	2.24	13.85	2.24	14.78	2.25
	23	9.89	2.38	11.00	2.39	11.84	2.40	12.27	2.40	13.59	2.42	14.49	2.43
	27	9.64	2.60	10.71	2.62	11.52	2.64	11.93	2.65	13.21	2.67	14.09	2.68
	31	9.37	2.85	10.40	2.88	11.18	2.90	11.58	2.91	12.82	2.94	13.67	2.96
	35	9.07	3.13	10.06	3.16	10.82	3.19	11.20	3.20	12.39	3.24	13.22	3.26
	39	8.75	3.43	9.70	3.47	10.42	3.50	10.80	3.51	11.95	3.56	12.74	3.59
	43	8.41	3.75	9.31	3.80	10.01	3.83	10.36	3.85	11.47	3.90	12.24	3.94
46	8.13	4.01	9.00	4.06	9.68	4.10	10.02	4.12	11.10	4.18	11.84	4.21	

3D052905

Symbols:
TC: Total capacity (kW)
PI: Power input (kW)

Notes:
1. This table shows outdoor unit cooling capacity and power input.
2. Is specified point.
3. PI of indoor units is not included in the table.

5 Capacity tables

5 - 1 Cooling capacity tables

RMXS112EV- Cooling capacity													
Combination %	Outdoor air temp. °CDB	Indoor air temp.: °CWB											
		14 °C		16 °C		18 °C		19 °C		22 °C		24 °C	
		TC kW	PI kW	TC kW	PI kW	TC kW	PI kW	TC kW	PI kW	TC kW	PI kW	TC kW	PI kW
90%	10	9.55	1.54	10.65	1.52	11.47	1.51	11.89	1.50	13.19	1.48	14.09	1.46
	14	9.38	1.68	10.45	1.67	11.25	1.66	11.65	1.65	12.92	1.64	13.79	1.63
	18	9.20	1.84	10.22	1.83	11.00	1.83	11.40	1.83	12.63	1.82	13.47	1.82
	20	9.10	1.93	10.11	1.93	10.87	1.93	11.26	1.92	12.47	1.92	13.30	1.92
	23	8.94	2.07	9.92	2.08	10.67	2.08	11.05	2.08	12.23	2.08	13.04	2.09
	27	8.71	2.29	9.65	2.30	10.38	2.31	10.75	2.31	11.89	2.32	12.68	2.33
	31	8.46	2.53	9.37	2.54	10.07	2.56	10.42	2.56	11.53	2.58	12.30	2.59
	35	8.19	2.79	9.06	2.81	9.73	2.83	10.08	2.84	11.15	2.86	11.89	2.88
	39	7.89	3.08	8.73	3.10	9.38	3.13	9.72	3.14	10.75	3.17	11.46	3.19
	43	7.58	3.39	8.38	3.42	9.01	3.44	9.33	3.46	10.32	3.50	11.01	3.52
46	7.33	3.63	8.10	3.67	8.71	3.70	9.02	3.71	9.99	3.76	10.66	3.79	
80%	10	8.50	1.29	9.46	1.27	10.19	1.25	10.57	1.24	11.72	1.21	12.52	1.19
	14	8.35	1.42	9.28	1.40	9.99	1.39	10.35	1.38	11.48	1.36	12.26	1.34
	18	8.18	1.56	9.08	1.55	9.77	1.54	10.13	1.54	11.22	1.52	11.98	1.52
	20	8.09	1.65	8.98	1.64	9.66	1.63	10.01	1.63	11.08	1.62	11.83	1.61
	23	7.95	1.78	8.81	1.77	9.47	1.77	9.82	1.77	10.87	1.77	11.60	1.76
	27	7.74	1.98	8.57	1.98	9.22	1.98	9.55	1.98	10.57	1.98	11.28	1.98
	31	7.52	2.20	8.32	2.21	8.94	2.21	9.26	2.22	10.25	2.22	10.94	2.23
	35	7.28	2.45	8.05	2.46	8.65	2.47	8.96	2.47	9.92	2.49	10.58	2.50
	39	7.02	2.72	7.76	2.73	8.34	2.75	8.64	2.75	9.56	2.78	10.20	2.79
	43	6.74	3.01	7.45	3.03	8.01	3.05	8.30	3.06	9.19	3.08	9.80	3.10
46	6.52	3.25	7.21	3.27	7.75	3.29	8.03	3.30	8.89	3.33	9.49	3.35	
70%	10	7.39	1.08	8.23	1.05	8.88	1.03	9.21	1.02	10.23	0.99	10.94	0.97
	14	7.26	1.18	8.07	1.16	8.71	1.14	9.03	1.13	10.03	1.11	10.72	1.09
	18	7.12	1.31	7.91	1.29	8.52	1.28	8.83	1.27	9.81	1.25	10.48	1.24
	20	7.04	1.38	7.82	1.36	8.42	1.35	8.73	1.35	9.69	1.34	10.35	1.33
	23	6.92	1.50	7.68	1.49	8.27	1.48	8.57	1.48	9.51	1.47	10.16	1.46
	27	6.75	1.67	7.48	1.67	8.05	1.67	8.34	1.67	9.25	1.66	9.88	1.66
	31	6.56	1.87	7.26	1.88	7.82	1.88	8.10	1.88	8.98	1.88	9.59	1.88
	35	6.35	2.10	7.03	2.10	7.56	2.11	7.84	2.11	8.69	2.12	9.28	2.12
	39	6.13	2.35	6.78	2.36	7.30	2.36	7.56	2.37	8.39	2.38	8.96	2.39
	43	5.89	2.62	6.51	2.63	7.01	2.64	7.27	2.65	8.07	2.66	8.62	2.68
46	5.70	2.84	6.30	2.85	6.79	2.87	7.04	2.87	7.81	2.89	8.35	2.91	
60%	10	6.22	0.89	6.95	0.87	7.52	0.85	7.81	0.84	8.72	0.81	9.35	0.79
	14	6.12	0.97	6.83	0.95	7.39	0.93	7.68	0.93	8.56	0.90	9.17	0.89
	18	6.01	1.07	6.70	1.05	7.25	1.04	7.52	1.04	8.38	1.02	8.98	1.01
	20	5.95	1.13	6.63	1.11	7.17	1.10	7.44	1.10	8.29	1.08	8.88	1.07
	23	5.86	1.23	6.52	1.22	7.05	1.21	7.31	1.20	8.15	1.19	8.72	1.19
	27	5.72	1.38	6.36	1.37	6.87	1.37	7.13	1.36	7.94	1.36	8.50	1.35
	31	5.57	1.55	6.19	1.55	6.68	1.54	6.93	1.54	7.72	1.54	8.26	1.54
	35	5.40	1.74	6.00	1.74	6.48	1.75	6.72	1.75	7.48	1.75	8.01	1.75
	39	5.22	1.96	5.79	1.97	6.26	1.97	6.49	1.97	7.23	1.98	7.74	1.99
	43	5.02	2.20	5.58	2.21	6.02	2.22	6.25	2.22	6.96	2.23	7.45	2.24
46	4.87	2.39	5.40	2.41	5.83	2.42	6.06	2.42	6.75	2.44	7.23	2.45	
50%	10	4.98	0.73	5.63	0.71	6.13	0.69	6.39	0.68	7.19	0.66	7.74	0.65
	14	4.93	0.78	5.55	0.76	6.05	0.75	6.30	0.74	7.07	0.73	7.61	0.71
	18	4.86	0.85	5.47	0.84	5.95	0.83	6.19	0.82	6.95	0.81	7.48	0.80
	20	4.82	0.89	5.42	0.88	5.89	0.87	6.13	0.87	6.88	0.86	7.40	0.85
	23	4.75	0.97	5.34	0.96	5.81	0.95	6.04	0.95	6.78	0.94	7.29	0.94
	27	4.66	1.09	5.23	1.08	5.68	1.08	5.91	1.08	6.62	1.07	7.12	1.07
	31	4.55	1.22	5.10	1.22	5.54	1.22	5.76	1.22	6.46	1.22	6.94	1.22
	35	4.43	1.38	4.96	1.38	5.38	1.38	5.60	1.38	6.27	1.39	6.74	1.39
	39	4.29	1.56	4.80	1.56	5.22	1.57	5.42	1.57	6.08	1.58	6.53	1.58
	43	4.14	1.76	4.63	1.76	5.03	1.77	5.23	1.77	5.87	1.79	6.30	1.80
46	4.02	1.92	4.50	1.93	4.88	1.94	5.08	1.94	5.70	1.96	6.12	1.97	

3D052905

Symbols:
 TC: Total capacity (kW)
 PI: Power input (kW)

Notes:
 1. This table shows outdoor unit cooling capacity and power input.
 2. □ Is specified point.
 3. PI of indoor units is not included in the table.

5 Capacity tables

5 - 1 Cooling capacity tables

RMXS140EV- Cooling capacity													
Combination %	Outdoor air temp. °CDB	Indoor air temp.: °CWB											
		14 °C		16 °C		18 °C		19 °C		22 °C		24 °C	
		TC kW	PI kW	TC kW	PI kW	TC kW	PI kW	TC kW	PI kW	TC kW	PI kW	TC kW	PI kW
130%	10	14.84	2.78	16.49	2.79	17.75	2.79	18.37	2.80	20.25	2.81	21.56	2.82
	14	14.55	2.98	16.14	2.99	17.36	3.01	17.96	3.02	19.79	3.05	21.05	3.07
	18	14.23	3.20	15.76	3.23	16.94	3.26	17.52	3.27	19.29	3.31	20.51	3.35
	20	14.06	3.32	15.56	3.36	16.72	3.39	17.29	3.41	19.03	3.46	20.23	3.50
	23	13.78	3.53	15.24	3.57	16.37	3.61	16.93	3.63	18.62	3.69	19.79	3.73
	27	13.39	3.82	14.78	3.88	15.87	3.93	16.41	3.95	18.04	4.03	19.18	4.08
	31	12.96	4.15	14.29	4.22	15.34	4.28	15.86	4.30	17.43	4.39	18.52	4.45
	35	12.49	4.51	13.77	4.59	14.77	4.65	15.27	4.69	16.78	4.78	17.83	4.85
	39	11.99	4.90	13.20	4.99	14.16	5.06	14.64	5.10	16.73	5.13	17.65	5.13
	43	11.47	5.13	12.53	5.13	13.35	5.13	13.75	5.13	14.95	5.13	15.78	5.13
46	8.69	4.10	9.52	4.10	10.16	4.10	10.49	4.10	11.42	4.10	12.17	4.10	
120%	10	14.57	2.74	16.21	2.74	17.45	2.74	18.05	2.75	19.90	2.76	21.20	2.77
	14	14.30	2.92	15.88	2.94	17.07	2.95	17.66	2.96	19.46	2.99	20.71	3.01
	18	14.00	3.14	15.52	3.17	16.67	3.20	17.24	3.21	18.98	3.25	20.20	3.28
	20	13.83	3.26	15.32	3.30	16.46	3.33	17.02	3.34	18.73	3.39	19.93	3.43
	23	13.57	3.46	15.02	3.50	16.12	3.54	16.67	3.56	18.34	3.62	19.50	3.66
	27	13.19	3.75	14.58	3.81	15.65	3.85	16.17	3.87	17.79	3.95	18.91	4.00
	31	12.78	4.07	14.11	4.14	15.13	4.19	15.64	4.22	17.20	4.30	18.28	4.36
	35	12.33	4.43	13.60	4.50	14.58	4.57	15.07	4.60	16.57	4.69	17.61	4.76
	39	11.84	4.81	13.05	4.90	14.00	4.97	14.46	5.00	15.90	5.11	17.43	5.13
	43	11.33	5.13	12.37	5.13	13.18	5.13	13.58	5.13	14.77	5.13	15.59	5.13
46	8.58	4.10	9.40	4.10	10.03	4.10	10.36	4.10	11.27	4.10	12.02	4.10	
110%	10	14.29	2.68	15.93	2.68	17.17	2.68	17.76	2.68	19.61	2.69	20.90	2.70
	14	14.03	2.86	15.61	2.87	16.81	2.89	17.39	2.89	19.18	2.92	20.43	2.94
	18	13.74	3.07	15.26	3.10	16.42	3.12	16.98	3.14	18.72	3.17	19.93	3.20
	20	13.58	3.19	15.08	3.23	16.22	3.25	16.77	3.27	18.47	3.31	19.67	3.35
	23	13.33	3.39	14.78	3.43	15.89	3.46	16.43	3.48	18.09	3.54	19.26	3.57
	27	12.97	3.67	14.36	3.73	15.43	3.77	15.94	3.79	17.55	3.86	18.68	3.91
	31	12.57	3.99	13.90	4.06	14.93	4.11	15.43	4.13	16.98	4.21	18.06	4.27
	35	12.13	4.34	13.40	4.42	14.39	4.48	14.87	4.51	16.37	4.60	17.41	4.66
	39	11.66	4.73	12.87	4.81	13.82	4.88	14.28	4.91	15.72	5.01	16.73	5.08
	43	11.19	5.13	12.22	5.13	13.02	5.13	13.41	5.13	14.58	5.13	15.39	5.13
46	8.47	4.10	9.28	4.10	9.90	4.10	10.22	4.10	11.13	4.10	11.86	4.10	
100%	10	13.35	2.45	14.93	2.44	16.14	2.44	16.70	2.44	18.47	2.45	19.72	2.45
	14	13.11	2.62	14.64	2.63	15.80	2.64	16.35	2.65	18.07	2.66	19.28	2.68
	18	12.83	2.83	14.31	2.85	15.44	2.87	15.97	2.87	17.63	2.90	18.80	2.93
	20	12.69	2.94	14.14	2.97	15.25	2.99	15.77	3.00	17.40	3.04	18.56	3.06
	23	12.45	3.12	13.86	3.16	14.94	3.19	15.45	3.20	17.04	3.25	18.17	3.28
	27	12.12	3.39	13.46	3.44	14.51	3.48	15.00	3.50	16.54	3.55	17.63	3.59
	31	11.74	3.69	13.04	3.75	14.04	3.80	14.52	3.82	16.00	3.89	17.05	3.94
	35	11.34	4.02	12.58	4.09	13.54	4.14	14.00	4.17	15.43	4.25	16.49	4.30
	39	10.91	4.39	12.08	4.46	13.01	4.52	13.45	4.55	14.82	4.64	15.80	4.70
	43	10.44	4.78	11.56	4.86	12.44	4.93	12.86	4.96	14.18	5.05	15.11	5.12
46	8.37	4.10	9.17	4.10	9.78	4.10	10.09	4.10	10.99	4.10	11.71	4.10	

3D052906

Symbols:
 TC: Total capacity (kW)
 PI: Power input (kW)

Notes:
 1. This table shows outdoor unit cooling capacity and power input.
 2. Is specified point.
 3. PI of indoor units is not included in the table.

5 Capacity tables

5 - 1 Cooling capacity tables

RMXS140EV- Cooling capacity													
Combination %	Outdoor air temp. °CDB	Indoor air temp.: °CWB											
		14 °C		16 °C		18 °C		19 °C		22 °C		24 °C	
		TC kW	PI kW	TC kW	PI kW	TC kW	PI kW	TC kW	PI kW	TC kW	PI kW	TC kW	PI kW
90%	10	11,97	2,05	13,39	2,04	14,47	2,04	15,01	2,03	16,63	2,02	17,76	2,02
	14	11,75	2,22	13,12	2,22	14,17	2,22	14,69	2,22	16,26	2,23	17,36	2,23
	18	11,50	2,42	12,83	2,43	13,84	2,44	14,35	2,44	15,87	2,45	16,94	2,46
	20	11,37	2,53	12,67	2,54	13,67	2,55	14,17	2,56	15,66	2,58	16,71	2,59
	23	11,16	2,70	12,43	2,72	13,40	2,74	13,88	2,75	15,34	2,77	16,37	2,79
	27	10,86	2,95	12,07	2,98	13,01	3,01	13,48	3,02	14,89	3,06	15,89	3,08
	31	10,53	3,23	11,70	3,27	12,60	3,30	13,06	3,32	14,42	3,36	15,37	3,39
	35	10,18	3,54	11,29	3,59	12,16	3,62	12,60	3,64	13,91	3,69	14,87	3,73
	39	9,80	3,87	10,86	3,93	11,69	3,97	12,12	3,99	13,38	4,05	14,27	4,09
	43	9,39	4,23	10,40	4,29	11,20	4,34	11,60	4,36	12,82	4,43	13,67	4,48
46	8,26	4,10	9,05	4,10	9,65	4,10	9,96	4,10	10,85	4,10	11,56	4,10	
80%	10	10,60	1,68	11,86	1,67	12,81	1,65	13,31	1,65	14,77	1,63	15,78	1,62
	14	10,40	1,84	11,62	1,83	12,54	1,83	13,03	1,82	14,44	1,81	15,43	1,81
	18	10,19	2,02	11,36	2,02	12,25	2,02	12,73	2,02	14,10	2,02	15,06	2,02
	20	10,07	2,12	11,22	2,12	12,10	2,13	12,57	2,13	13,92	2,13	14,86	2,13
	23	9,88	2,28	11,01	2,29	11,86	2,30	12,32	2,30	13,64	2,31	14,56	2,32
	27	9,62	2,51	10,70	2,53	11,53	2,54	11,97	2,55	13,24	2,57	14,14	2,58
	31	9,33	2,77	10,37	2,79	11,17	2,81	11,60	2,82	12,83	2,84	13,69	2,86
	35	9,03	3,05	10,02	3,08	10,79	3,10	11,20	3,11	12,39	3,15	13,22	3,17
	39	8,70	3,35	9,64	3,39	10,39	3,41	10,78	3,43	11,93	3,47	12,73	3,50
	43	8,34	3,68	9,25	3,72	9,96	3,75	10,34	3,77	11,44	3,81	12,21	3,84
46	8,06	3,94	8,93	3,98	9,52	4,02	9,89	4,03	10,68	4,08	11,41	4,10	
70%	10	9,24	1,34	10,33	1,32	11,16	1,30	11,61	1,30	12,89	1,27	13,78	1,25
	14	9,07	1,48	10,13	1,46	10,93	1,45	11,37	1,45	12,61	1,43	13,48	1,42
	18	8,88	1,64	9,90	1,63	10,68	1,62	11,11	1,62	12,32	1,61	13,16	1,60
	20	8,78	1,72	9,79	1,72	10,55	1,72	10,97	1,71	12,16	1,71	13,00	1,70
	23	8,62	1,87	9,60	1,87	10,35	1,86	10,76	1,86	11,92	1,86	12,74	1,86
	27	8,39	2,07	9,34	2,08	10,06	2,08	10,46	2,08	11,59	2,09	12,38	2,09
	31	8,15	2,30	9,06	2,31	9,76	2,32	10,14	2,32	11,23	2,33	12,00	2,34
	35	7,88	2,55	8,76	2,57	9,43	2,58	9,80	2,58	10,86	2,60	11,59	2,61
	39	7,60	2,82	8,44	2,84	9,09	2,86	9,44	2,87	10,46	2,89	11,17	2,90
	43	7,30	3,11	8,10	3,14	8,72	3,16	9,06	3,17	10,05	3,20	10,73	3,22
46	7,06	3,34	7,83	3,37	8,44	3,40	8,77	3,41	9,72	3,44	10,39	3,46	
60%	10	7,88	1,03	8,81	1,01	9,51	0,99	9,90	0,98	11,00	0,96	11,77	0,94
	14	7,74	1,14	8,64	1,12	9,33	1,11	9,70	1,10	10,78	1,08	11,52	1,07
	18	7,58	1,27	8,46	1,26	9,12	1,25	9,48	1,24	10,53	1,23	11,26	1,22
	20	7,50	1,34	8,36	1,33	9,02	1,32	9,37	1,32	10,40	1,31	11,12	1,30
	23	7,37	1,46	8,21	1,45	8,85	1,45	9,20	1,44	10,21	1,44	10,91	1,43
	27	7,18	1,63	7,99	1,63	8,61	1,63	8,95	1,63	9,93	1,63	10,61	1,62
	31	6,98	1,82	7,75	1,83	8,36	1,83	8,68	1,83	9,63	1,83	10,29	1,84
	35	6,75	2,04	7,50	2,05	8,09	2,05	8,40	2,06	9,32	2,06	9,96	2,07
	39	6,52	2,27	7,24	2,29	7,80	2,29	8,10	2,30	8,99	2,31	9,60	2,32
	43	6,26	2,53	6,95	2,55	7,49	2,56	7,78	2,56	8,64	2,58	9,23	2,59
46	6,06	2,74	6,72	2,75	7,25	2,77	7,53	2,78	8,36	2,80	8,94	2,81	
50%	10	6,52	0,75	7,29	0,73	7,87	0,72	8,17	0,71	9,10	0,69	9,73	0,67
	14	6,42	0,82	7,17	0,81	7,73	0,79	8,03	0,79	8,93	0,77	9,54	0,76
	18	6,30	0,91	7,03	0,90	7,58	0,89	7,86	0,89	8,74	0,87	9,34	0,87
	20	6,23	0,97	6,95	0,95	7,49	0,95	7,77	0,94	8,64	0,93	9,23	0,93
	23	6,13	1,05	6,83	1,05	7,36	1,04	7,64	1,04	8,48	1,03	9,07	1,03
	27	5,98	1,19	6,66	1,18	7,17	1,18	7,44	1,18	8,26	1,18	8,83	1,18
	31	5,82	1,34	6,47	1,34	6,97	1,34	7,23	1,34	8,03	1,35	8,58	1,35
	35	5,64	1,52	6,26	1,52	6,75	1,52	7,00	1,53	7,77	1,53	8,32	1,54
	39	5,44	1,71	6,04	1,72	6,51	1,73	6,76	1,73	7,50	1,74	8,02	1,75
	43	5,23	1,93	5,81	1,94	6,26	1,95	6,49	1,95	7,22	1,97	7,72	1,98
46	5,06	2,10	5,62	2,12	6,06	2,13	6,29	2,13	6,99	2,15	7,48	2,16	

3D052906

Symbols:
 TC: Total capacity (kW)
 PI: Power input (kW)

Notes:
 1. This table shows outdoor unit cooling capacity and power input.
 2. □ Is specified point.
 3. PI of indoor units is not included in the table.

5 Capacity tables

5 - 1 Cooling capacity tables

RMXS160EV- Cooling capacity

Combination %	Outdoor air temp. °CDB	Indoor air temp.: °CWB											
		14 °C		16 °C		18 °C		19 °C		22 °C		24 °C	
		TC kW	PI kW	TC kW	PI kW	TC kW	PI kW	TC kW	PI kW	TC kW	PI kW	TC kW	PI kW
130%	10	15.66	2.95	17.65	2.96	19.02	2.97	19.67	2.98	21.69	3.00	23.08	3.02
	14	15.37	3.16	17.28	3.19	18.60	3.21	19.24	3.22	21.20	3.26	22.54	3.29
	18	15.04	3.40	16.88	3.45	18.16	3.48	18.77	3.50	20.67	3.55	21.97	3.59
	20	14.86	3.54	16.66	3.59	17.92	3.63	18.53	3.65	20.39	3.71	21.67	3.76
	23	14.58	3.75	16.32	3.82	17.55	3.87	18.14	3.89	19.95	3.96	21.20	4.02
	27	14.17	4.08	15.84	4.15	17.02	4.21	17.59	4.24	19.34	4.33	20.55	4.39
	31	13.72	4.43	15.32	4.53	16.45	4.59	17.00	4.63	18.69	4.73	19.86	4.80
	35	13.23	4.82	14.76	4.93	15.85	5.01	16.38	5.04	18.00	5.16	19.12	5.24
	39	12.71	5.25	13.66	5.27	14.69	5.27	15.07	5.27	16.42	5.27	17.33	5.27
	43	11.23	5.27	12.29	5.27	13.20	5.27	13.55	5.27	14.79	5.27	15.62	5.27
46	8.69	4.18	9.63	4.18	10.28	4.18	10.59	4.18	11.63	4.18	12.50	4.18	
120%	10	15.31	2.96	17.25	2.97	18.60	2.98	19.26	2.98	21.28	3.00	22.66	3.02
	14	15.03	3.16	16.90	3.19	18.21	3.21	18.85	3.22	20.80	3.26	22.14	3.29
	18	14.71	3.40	16.52	3.45	17.78	3.48	18.40	3.49	20.29	3.55	21.59	3.59
	20	14.54	3.54	16.31	3.59	17.55	3.63	18.16	3.64	20.02	3.71	21.30	3.75
	23	14.27	3.75	15.99	3.82	17.19	3.86	17.79	3.88	19.60	3.96	20.85	4.01
	27	13.88	4.07	15.52	4.15	16.69	4.21	17.26	4.23	19.01	4.32	20.21	4.39
	31	13.45	4.43	15.02	4.52	16.14	4.59	16.69	4.62	18.38	4.72	19.54	4.79
	35	12.98	4.82	14.48	4.92	15.56	5.00	16.08	5.04	17.71	5.15	18.83	5.23
	39	12.47	5.25	13.49	5.27	14.51	5.27	14.88	5.27	16.22	5.27	17.11	5.27
	43	11.09	5.27	12.14	5.27	13.03	5.27	13.38	5.27	14.60	5.27	15.42	5.27
46	8.58	4.18	9.51	4.18	10.15	4.18	10.46	4.18	11.49	4.18	12.34	4.18	
110%	10	14.97	2.96	16.86	2.97	18.19	2.97	18.85	2.98	20.87	3.00	22.25	3.02
	14	14.70	3.17	16.53	3.19	17.81	3.20	18.45	3.22	20.41	3.26	21.75	3.29
	18	14.40	3.40	16.16	3.45	17.40	3.47	18.02	3.49	19.92	3.55	21.22	3.58
	20	14.24	3.54	15.96	3.59	17.18	3.61	17.79	3.64	19.66	3.70	20.94	3.75
	23	13.98	3.75	15.65	3.81	16.84	3.85	17.44	3.88	19.26	3.95	20.50	4.01
	27	13.60	4.07	15.21	4.15	16.35	4.19	16.93	4.23	18.68	4.32	19.88	4.38
	31	13.19	4.42	14.72	4.51	15.83	4.57	16.38	4.61	18.07	4.71	19.23	4.79
	35	12.74	4.81	14.20	4.92	15.26	4.98	15.79	5.03	17.43	5.14	18.54	5.22
	39	12.25	5.24	13.31	5.27	14.33	5.27	14.69	5.27	16.01	5.27	16.89	5.27
	43	10.95	5.27	11.98	5.27	12.87	5.27	13.21	5.27	14.42	5.27	15.23	5.27
46	8.47	4.18	9.39	4.18	10.02	4.18	10.33	4.18	11.34	4.18	12.18	4.18	
100%	10	14.64	2.97	16.48	2.98	17.77	2.95	18.44	2.99	20.47	3.01	21.84	3.02
	14	14.39	3.17	16.16	3.19	17.42	3.18	18.06	3.22	20.03	3.26	21.36	3.29
	18	14.10	3.41	15.91	3.45	17.03	3.44	17.65	3.49	19.56	3.54	20.84	3.58
	20	13.94	3.54	15.63	3.58	16.82	3.58	17.43	3.64	19.31	3.70	20.57	3.74
	23	13.70	3.75	15.33	3.81	16.49	3.82	17.09	3.88	18.91	3.95	20.15	4.00
	27	13.33	4.07	14.90	4.14	16.02	4.15	16.60	4.22	18.36	4.31	19.55	4.37
	31	12.93	4.42	14.43	4.51	15.51	4.53	16.07	4.60	17.77	4.71	18.92	4.78
	35	12.50	4.81	13.93	4.91	14.97	4.93	15.50	5.02	17.14	5.14	18.25	5.22
	39	12.02	5.24	13.14	5.27	14.14	5.27	14.50	5.27	15.81	5.27	16.68	5.27
	43	10.81	5.27	11.83	5.27	12.70	5.27	13.04	5.27	14.23	5.27	15.03	5.27
46	8.36	4.18	9.27	4.18	9.89	4.18	10.19	4.18	11.20	4.18	12.03	4.18	

3D052907

Symbols:
TC: Total capacity (kW)
PI: Power input (kW)

Notes:
1. This table shows outdoor unit cooling capacity and power input.
2. □ Is specified point.
3. PI of indoor units is not included in the table.

5 Capacity tables

5 - 1 Cooling capacity tables

RMXS160EV- Cooling capacity													
Combination %	Outdoor air temp. °CDB	Indoor air temp.: °CWB											
		14 °C		16 °C		18 °C		19 °C		22 °C		24 °C	
		TC kW	PI kW	TC kW	PI kW	TC kW	PI kW	TC kW	PI kW	TC kW	PI kW	TC kW	PI kW
90%	10	13,05	2,49	14,64	2,49	15,89	2,47	16,49	2,49	18,34	2,49	19,60	2,49
	14	12,83	2,68	14,37	2,69	15,58	2,68	16,17	2,71	17,96	2,72	19,18	2,74
	18	12,59	2,90	14,17	2,93	15,24	2,93	15,81	2,95	17,55	2,98	18,73	3,01
	20	12,45	3,02	13,91	3,05	15,06	3,06	15,62	3,09	17,33	3,13	18,50	3,15
	23	12,24	3,22	13,65	3,26	14,77	3,27	15,32	3,31	16,99	3,35	18,13	3,39
	27	11,92	3,51	13,28	3,56	14,37	3,58	14,89	3,62	16,51	3,68	17,61	3,72
	31	11,58	3,83	12,89	3,89	13,93	3,92	14,44	3,96	16,00	4,04	17,06	4,09
	35	11,20	4,18	12,46	4,26	13,46	4,29	13,95	4,34	15,46	4,42	16,48	4,48
	39	10,80	4,57	11,99	4,65	12,96	4,68	13,43	4,74	14,88	4,84	15,87	4,90
43	10,36	4,98	11,50	5,07	12,42	5,11	12,88	5,18	14,05	5,27	14,84	5,27	
46	8,25	4,18	9,15	4,18	9,76	4,18	10,06	4,18	11,05	4,18	11,87	4,18	
80%	10	11,51	2,02	12,92	2,02	14,04	2,00	14,59	2,00	16,25	1,99	17,38	1,99
	14	11,32	2,20	12,69	2,20	13,77	2,19	14,30	2,20	15,92	2,20	17,02	2,20
	18	11,11	2,40	12,53	2,41	13,48	2,41	13,99	2,42	15,56	2,43	16,63	2,44
	20	10,99	2,51	12,29	2,53	13,33	2,53	13,83	2,54	15,38	2,56	16,43	2,57
	23	10,81	2,69	12,07	2,71	13,08	2,72	13,57	2,74	15,08	2,76	16,11	2,78
	27	10,54	2,95	11,76	2,98	12,73	3,00	13,21	3,02	14,67	3,05	15,67	3,08
	31	10,25	3,24	11,41	3,28	12,36	3,30	12,82	3,32	14,23	3,37	15,19	3,40
	35	9,93	3,55	11,05	3,60	11,96	3,63	12,40	3,66	13,76	3,71	14,69	3,75
	39	9,58	3,89	10,65	3,95	11,53	3,98	11,96	4,01	13,27	4,08	14,17	4,12
43	9,21	4,26	10,23	4,33	11,07	4,37	11,48	4,40	12,75	4,47	13,61	4,52	
46	8,14	4,18	9,03	4,18	9,63	4,18	9,93	4,18	10,90	4,18	11,72	4,18	
70%	10	10,02	1,57	11,32	1,56	12,24	1,55	12,72	1,54	14,19	1,52	15,19	1,51
	14	9,85	1,72	11,12	1,72	12,01	1,71	12,47	1,71	13,90	1,70	14,87	1,69
	18	9,67	1,90	10,99	1,90	11,76	1,90	12,21	1,90	13,60	1,90	14,54	1,90
	20	9,57	2,00	10,77	2,00	11,62	2,00	12,07	2,00	13,44	2,01	14,37	2,01
	23	9,41	2,15	10,58	2,16	11,41	2,17	11,85	2,17	13,19	2,18	14,10	2,19
	27	9,18	2,38	10,31	2,40	11,12	2,41	11,54	2,42	12,84	2,43	13,72	2,45
	31	8,93	2,63	10,02	2,66	10,80	2,67	11,21	2,68	12,46	2,71	13,32	2,73
	35	8,66	2,91	9,70	2,94	10,45	2,96	10,85	2,97	12,06	3,01	12,89	3,03
	39	8,37	3,21	9,37	3,25	10,09	3,27	10,47	3,29	11,64	3,33	12,44	3,36
43	8,05	3,53	9,00	3,58	9,70	3,61	10,07	3,63	11,20	3,67	11,97	3,71	
46	7,80	3,79	8,72	3,84	9,40	3,88	9,75	3,89	10,85	3,95	11,53	3,98	
60%	10	8,56	1,14	9,84	1,12	10,47	1,11	10,89	1,10	12,15	1,07	13,01	1,05
	14	8,42	1,26	9,66	1,24	10,28	1,24	10,68	1,23	11,91	1,21	12,75	1,20
	18	8,27	1,41	9,56	1,39	10,06	1,39	10,45	1,39	11,65	1,38	12,47	1,37
	20	8,18	1,48	9,36	1,48	9,95	1,48	10,34	1,47	11,52	1,47	12,32	1,46
	23	8,05	1,61	9,19	1,61	9,77	1,61	10,15	1,61	11,31	1,61	12,09	1,61
	27	7,85	1,81	8,95	1,81	9,52	1,82	9,89	1,82	11,01	1,82	11,77	1,83
	31	7,64	2,02	8,70	2,03	9,25	2,04	9,60	2,04	10,69	2,05	11,43	2,06
	35	7,41	2,26	8,42	2,28	8,96	2,29	9,30	2,29	10,35	2,31	11,07	2,32
	39	7,16	2,52	8,13	2,54	8,65	2,56	8,98	2,56	9,99	2,59	10,69	2,60
43	6,89	2,80	7,82	2,83	8,32	2,85	8,64	2,85	9,62	2,88	10,29	2,90	
46	6,67	3,02	7,57	3,06	8,06	3,08	8,37	3,09	9,32	3,12	10,12	3,14	
50%	10	7,16	0,73	8,47	0,69	8,75	0,68	9,09	0,67	10,15	0,65	10,87	0,63
	14	7,04	0,81	8,31	0,78	8,58	0,77	8,92	0,77	9,95	0,75	10,65	0,74
	18	6,90	0,92	8,23	0,90	8,40	0,89	8,73	0,88	9,73	0,87	10,41	0,86
	20	6,83	0,98	8,04	0,96	8,31	0,95	8,63	0,95	9,61	0,94	10,29	0,93
	23	6,71	1,08	7,89	1,07	8,15	1,06	8,47	1,06	9,44	1,05	10,10	1,05
	27	6,55	1,23	7,68	1,22	7,94	1,22	8,25	1,22	9,18	1,22	9,82	1,22
	31	6,36	1,40	7,45	1,40	7,71	1,40	8,01	1,40	8,91	1,41	9,54	1,41
	35	6,17	1,60	7,20	1,61	7,46	1,60	7,75	1,61	8,63	1,62	9,23	1,62
	39	5,95	1,81	6,94	1,83	7,20	1,83	7,48	1,83	8,33	1,85	8,91	1,86
43	5,72	2,05	6,66	2,07	6,92	2,07	7,19	2,08	8,01	2,10	8,57	2,11	
46	5,54	2,24	6,44	2,27	6,70	2,27	6,96	2,28	7,76	2,30	8,25	2,32	

3D052907

Symbols:
 TC: Total capacity (kW)
 PI: Power input (kW)

Notes:
 1. This table shows outdoor unit cooling capacity and power input.
 2. □ Is specified point.
 3. PI of indoor units is not included in the table.

5 Capacity tables

5 - 2 Heating capacity tables

RMXS112EV- Heating capacity													
Combination %	Outdoor air temp. °CDB	Indoor air temp.: °CDB											
		14 °C		16 °C		18 °C		19 °C		22 °C		24 °C	
		TC kW	PI kW	TC kW	PI kW	TC kW	PI kW	TC kW	PI kW	TC kW	PI kW	TC kW	PI kW
130%	-15	7,77	3,23	7,79	3,34	7,81	3,46	7,81	3,53	7,82	3,59	7,83	3,71
	-11	8,83	3,31	8,82	3,44	8,81	3,57	8,81	3,64	8,80	3,70	8,79	3,83
	-7	9,95	3,41	9,93	3,54	9,89	3,68	9,88	3,76	9,86	3,82	9,83	3,95
	-3	11,14	3,51	11,09	3,66	11,04	3,81	11,02	3,89	10,99	3,96	10,95	4,09
	0	12,07	3,60	12,01	3,75	11,95	3,91	11,91	3,99	11,88	4,07	11,83	4,21
	2	12,71	3,66	12,64	3,82	12,57	3,98	12,53	4,07	12,49	4,15	12,43	4,29
	6	14,03	3,80	13,94	3,97	13,85	4,14	13,80	4,24	13,76	4,31	13,69	4,46
	10	15,41	3,95	15,30	4,13	15,19	4,32	15,13	4,41	15,08	4,50	15,00	4,65
	12	16,11	4,04	15,99	4,22	15,88	4,41	15,82	4,51	15,77	4,60	15,68	4,75
15	17,19	4,17	17,06	4,37	16,93	4,56	16,87	4,67	16,81	4,76	16,72	4,91	
120%	-15	7,80	3,10	7,82	3,21	7,83	3,34	7,83	3,40	7,84	3,47	7,84	3,63
	-11	8,83	3,20	8,82	3,33	8,81	3,47	8,80	3,54	8,79	3,61	8,77	3,77
	-7	9,92	3,33	9,89	3,46	9,85	3,61	9,84	3,68	9,82	3,76	9,77	3,94
	-3	11,08	3,46	11,02	3,61	10,97	3,76	10,94	3,84	10,91	3,93	10,84	4,12
	0	11,98	3,58	11,91	3,73	11,84	3,89	11,80	3,98	11,77	4,06	11,68	4,27
	2	12,59	3,66	12,52	3,82	12,44	3,99	12,40	4,07	12,35	4,16	12,26	4,37
	6	13,87	3,83	13,77	4,01	13,67	4,18	13,62	4,28	13,57	4,37	13,45	4,59
	10	15,18	4,03	15,07	4,21	14,96	4,40	14,90	4,50	14,84	4,60	14,70	4,84
	12	15,86	4,14	15,74	4,33	15,62	4,52	15,56	4,62	15,50	4,72	15,35	4,97
15	16,90	4,31	16,77	4,51	16,64	4,71	16,57	4,81	16,50	4,92	16,34	5,18	
110%	-15	7,68	3,07	7,69	3,19	7,71	3,32	7,71	3,39	7,71	3,46	7,72	3,61
	-11	8,70	3,19	8,69	3,32	8,68	3,46	8,67	3,53	8,66	3,60	8,64	3,77
	-7	9,78	3,32	9,75	3,46	9,71	3,61	9,69	3,69	9,67	3,76	9,63	3,94
	-3	10,92	3,47	10,87	3,62	10,81	3,78	10,78	3,86	10,75	3,94	10,68	4,13
	0	11,81	3,59	11,74	3,75	11,67	3,91	11,63	4,00	11,60	4,09	11,51	4,28
	2	12,42	3,68	12,34	3,84	12,26	4,01	12,22	4,10	12,17	4,19	12,08	4,39
	6	13,67	3,86	13,57	4,04	13,47	4,22	13,42	4,31	13,37	4,41	13,26	4,63
	10	14,96	4,07	14,85	4,26	14,74	4,45	14,68	4,55	14,62	4,65	14,49	4,88
	12	15,63	4,19	15,51	4,38	15,39	4,58	15,32	4,68	15,26	4,78	15,12	5,02
15	16,64	4,37	16,51	4,57	16,38	4,78	16,31	4,88	16,24	4,99	16,09	5,24	
100%	-15	6,99	2,91	7,00	3,02	7,01	3,15	7,01	3,21	7,02	3,27	7,02	3,38
	-11	7,96	3,01	7,95	3,14	7,94	3,27	7,93	3,34	7,93	3,40	7,92	3,51
	-7	8,99	3,12	8,96	3,26	8,93	3,40	8,91	3,47	8,90	3,54	8,87	3,65
	-3	10,07	3,25	10,02	3,39	9,97	3,55	9,94	3,62	9,92	3,69	9,89	3,80
	0	10,92	3,37	10,85	3,51	10,79	3,66	10,75	3,75	10,73	3,82	10,68	3,93
	2	11,49	3,43	11,42	3,59	11,35	3,75	11,31	3,83	11,28	3,90	11,23	4,02
	6	12,68	3,59	12,59	3,76	12,50	3,93	12,45	4,02	12,42	4,09	12,36	4,20
	10	13,91	3,77	13,80	3,95	13,70	4,13	13,64	4,22	13,60	4,30	13,54	4,41
	12	14,54	3,86	14,43	4,05	14,31	4,24	14,26	4,33	14,21	4,41	14,15	4,52
15	15,50	4,02	15,38	4,21	15,26	4,41	15,19	4,51	15,14	4,59	15,08	4,69	

3D052908

Symbols:
 TC: Total capacity (kW)
 PI: Power input (kW)

Notes:
 1. This table shows outdoor unit cooling capacity and power input.
 2. Is specified point.
 3. PI of indoor units is not included in the table.

5 Capacity tables

5 - 2 Heating capacity tables

RMXS112EV- Heating capacity													
Combination %	Outdoor air temp. °CDB	Indoor air temp.: °CDB											
		14 °C		16 °C		18 °C		19 °C		22 °C		24 °C	
		TC kW	PI kW	TC kW	PI kW	TC kW	PI kW	TC kW	PI kW	TC kW	PI kW	TC kW	PI kW
90%	-15	6,24	2,59	6,26	2,70	6,26	2,82	6,27	2,88	6,27	2,94	6,27	3,03
	-11	7,16	2,69	7,15	2,81	7,14	2,94	7,13	3,01	7,13	3,07	7,12	3,15
	-7	8,12	2,81	8,09	2,94	8,06	3,07	8,04	3,15	8,03	3,20	8,01	3,29
	-3	9,12	2,93	9,07	3,07	9,03	3,22	9,00	3,29	8,98	3,35	8,96	3,43
	0	9,90	3,05	9,84	3,18	9,78	3,34	9,75	3,42	9,72	3,48	9,69	3,55
	2	10,43	3,11	10,36	3,26	10,29	3,42	10,26	3,50	10,23	3,56	10,20	3,64
	6	11,52	3,27	11,44	3,43	11,35	3,59	11,31	3,68	11,28	3,74	11,24	3,81
	10	12,64	3,44	12,55	3,61	12,45	3,79	12,40	3,88	12,36	3,94	12,33	4,01
80%	-15	5,51	2,29	5,52	2,40	5,52	2,51	5,53	2,57	5,53	2,62	5,54	2,70
	-11	6,35	2,39	6,35	2,50	6,34	2,63	6,33	2,69	6,33	2,74	6,32	2,81
	-7	7,24	2,50	7,21	2,62	7,19	2,75	7,17	2,82	7,16	2,88	7,15	2,94
	-3	8,16	2,62	8,12	2,75	8,08	2,89	8,05	2,97	8,04	3,02	8,02	3,08
	0	8,88	2,73	8,82	2,86	8,77	3,01	8,74	3,08	8,72	3,14	8,70	3,19
	2	9,36	2,80	9,30	2,94	9,24	3,09	9,20	3,17	9,18	3,22	9,16	3,27
	6	10,36	2,95	10,28	3,10	10,20	3,26	10,16	3,34	10,14	3,40	10,12	3,44
	10	11,38	3,12	11,29	3,28	11,20	3,45	11,15	3,53	11,12	3,59	11,11	3,62
70%	-15	4,77	2,01	4,78	2,11	4,79	2,22	4,80	2,28	4,80	2,33	4,80	2,39
	-11	5,55	2,10	5,54	2,21	5,53	2,33	5,53	2,39	5,53	2,44	5,52	2,50
	-7	6,36	2,20	6,34	2,32	6,31	2,44	6,30	2,51	6,29	2,56	6,28	2,62
	-3	7,20	2,32	7,16	2,44	7,12	2,57	7,10	2,64	7,09	2,69	7,07	2,75
	0	7,85	2,42	7,80	2,54	7,75	2,68	7,73	2,76	7,71	2,80	7,69	2,85
	2	8,29	2,48	8,23	2,62	8,18	2,76	8,15	2,83	8,13	2,88	8,12	2,93
	6	9,19	2,63	9,12	2,77	9,05	2,92	9,02	3,00	9,00	3,05	8,98	3,09
	10	10,12	2,80	10,04	2,95	9,96	3,11	9,92	3,19	9,89	3,24	9,88	3,26
60%	-15	4,05	1,76	4,06	1,85	4,07	1,95	4,07	2,01	4,07	2,05	4,08	2,12
	-11	4,74	1,84	4,74	1,93	4,73	2,04	4,73	2,10	4,73	2,14	4,73	2,21
	-7	5,47	1,92	5,45	2,03	5,43	2,14	5,42	2,20	5,42	2,25	5,41	2,31
	-3	6,23	2,02	6,20	2,14	6,16	2,26	6,15	2,32	6,14	2,37	6,12	2,43
	0	6,81	2,11	6,77	2,23	6,73	2,36	6,71	2,43	6,69	2,47	6,68	2,53
	2	7,21	2,17	7,16	2,30	7,12	2,43	7,09	2,50	7,08	2,55	7,06	2,60
	6	8,03	2,31	7,97	2,45	7,91	2,59	7,88	2,66	7,86	2,71	7,84	2,76
	10	8,86	2,47	8,79	2,62	8,72	2,77	8,69	2,85	8,67	2,89	8,65	2,93
50%	-15	3,32	1,54	3,33	1,62	3,34	1,71	3,35	1,75	3,35	1,79	3,36	1,87
	-11	3,93	1,59	3,93	1,67	3,93	1,77	3,93	1,82	3,93	1,86	3,93	1,94
	-7	4,58	1,65	4,56	1,75	4,55	1,85	4,54	1,90	4,54	1,94	4,53	2,02
	-3	5,25	1,73	5,22	1,84	5,20	1,95	5,19	2,01	5,18	2,05	5,16	2,13
	0	5,77	1,81	5,74	1,92	5,70	2,04	5,69	2,10	5,68	2,14	5,65	2,22
	2	6,13	1,86	6,09	1,98	6,05	2,10	6,03	2,17	6,02	2,21	6,00	2,29
	6	6,86	1,99	6,81	2,12	6,76	2,25	6,73	2,32	6,72	2,37	6,69	2,45
	10	7,61	2,15	7,55	2,28	7,49	2,43	7,46	2,50	7,45	2,55	7,42	2,62

3D052908

Symbols:
TC: Total capacity (kW)
PI: Power input (kW)

Notes:
1. This table shows outdoor unit cooling capacity and power input.
2. □ Is specified point.
3. PI of indoor units is not included in the table.

5 Capacity tables

5 - 2 Heating capacity tables

RMXS140EV- Heating capacity													
Combination %	Outdoor air temp. °CDB	Indoor air temp.: °CDB											
		14 °C		16 °C		18 °C		19 °C		22 °C		24 °C	
		TC kW	PI kW	TC kW	PI kW	TC kW	PI kW	TC kW	PI kW	TC kW	PI kW	TC kW	PI kW
130%	-15	9,54	3,36	9,57	3,46	9,59	3,58	9,60	3,64	9,61	3,70	9,63	3,83
	-11	10,79	3,44	10,79	3,55	10,79	3,68	10,78	3,74	10,78	3,81	10,76	3,95
	-7	12,14	3,53	12,11	3,65	12,07	3,79	12,06	3,86	12,04	3,93	12,00	4,08
	-3	13,57	3,63	13,51	3,76	13,45	3,91	13,42	3,98	13,39	4,06	13,32	4,22
	0	14,69	3,71	14,61	3,85	14,53	4,01	14,49	4,08	14,45	4,17	14,37	4,33
	2	15,46	3,77	15,36	3,92	15,28	4,08	15,23	4,16	15,19	4,24	15,09	4,42
	6	17,04	3,90	16,93	4,06	16,82	4,23	16,77	4,32	16,71	4,41	16,59	4,59
	10	18,69	4,05	18,56	4,22	18,43	4,40	18,36	4,49	18,30	4,59	18,16	4,78
	12	19,54	4,13	19,39	4,31	19,25	4,49	19,18	4,59	19,11	4,69	18,97	4,89
15	20,84	4,26	20,67	4,45	20,52	4,64	20,45	4,74	20,37	4,84	20,21	5,05	
120%	-15	9,51	3,41	9,53	3,52	9,55	3,65	9,56	3,71	9,56	3,78	9,57	3,92
	-11	10,72	3,51	10,72	3,63	10,71	3,77	10,70	3,84	10,69	3,91	10,67	4,06
	-7	12,03	3,63	12,00	3,76	11,96	3,90	11,94	3,98	11,92	4,06	11,87	4,22
	-3	13,41	3,76	13,35	3,90	13,29	4,06	13,26	4,14	13,22	4,22	13,15	4,39
	0	14,49	3,87	14,42	4,02	14,34	4,18	14,30	4,27	14,25	4,35	14,17	4,54
	2	15,24	3,94	15,15	4,10	15,06	4,27	15,01	4,36	14,96	4,45	14,86	4,64
	6	16,77	4,11	16,66	4,29	16,55	4,47	16,49	4,56	16,43	4,65	16,31	4,85
	10	18,36	4,31	18,23	4,49	18,10	4,68	18,03	4,78	17,96	4,88	17,82	5,09
	12	19,17	4,41	19,04	4,60	18,89	4,80	18,82	4,90	18,75	5,01	18,60	5,22
15	20,42	4,58	20,27	4,78	20,11	4,99	20,04	5,09	19,96	5,20	19,79	5,43	
110%	-15	9,44	3,48	9,46	3,60	9,48	3,73	9,48	3,80	9,49	3,87	9,50	4,03
	-11	10,63	3,60	10,62	3,73	10,61	3,88	10,60	3,95	10,59	4,03	10,57	4,19
	-7	11,90	3,74	11,86	3,88	11,82	4,04	11,80	4,12	11,78	4,20	11,73	4,37
	-3	13,25	3,90	13,18	4,05	13,12	4,22	13,08	4,30	13,05	4,39	12,97	4,58
	0	14,30	4,03	14,22	4,19	14,13	4,37	14,09	4,46	14,05	4,55	13,95	4,74
	2	15,02	4,12	14,93	4,29	14,83	4,47	14,78	4,57	14,73	4,66	14,63	4,86
	6	16,50	4,33	16,39	4,51	16,27	4,70	16,21	4,80	16,15	4,90	16,03	5,11
	10	18,04	4,56	17,91	4,75	17,77	4,96	17,70	5,06	17,63	5,17	17,49	5,40
	12	18,83	4,69	18,69	4,89	18,54	5,10	18,47	5,20	18,39	5,31	17,07	5,45
15	20,03	4,89	19,88	5,10	19,72	5,32	19,64	5,43	18,39	5,45	17,44	5,45	
100%	-15	9,35	3,57	9,37	3,70	9,38	3,84	9,39	3,91	9,39	3,99	9,39	4,15
	-11	10,51	3,71	10,50	3,85	10,49	4,00	10,48	4,08	10,46	4,16	10,44	4,33
	-7	11,76	3,87	11,72	4,02	11,67	4,18	11,65	4,27	11,62	4,35	11,57	4,54
	-3	13,07	4,05	13,00	4,21	12,93	4,39	12,90	4,48	12,86	4,57	12,78	4,76
	0	14,09	4,20	14,01	4,38	13,92	4,56	13,88	4,65	13,83	4,75	13,74	4,95
	2	14,79	4,31	14,70	4,49	14,60	4,68	14,55	4,77	14,50	4,87	14,39	5,08
	6	16,23	4,55	16,12	4,74	16,00	4,94	15,94	5,04	15,88	5,15	15,75	5,37
	10	17,73	4,81	17,59	5,02	17,46	5,23	17,39	5,34	17,44	5,45	16,56	5,45
	12	18,49	4,96	18,35	5,17	18,20	5,39	18,18	5,45	17,74	5,45	16,85	5,45
15	19,66	5,18	19,51	5,41	19,08	5,45	18,61	5,45	18,16	5,45	17,22	5,45	

3D052909

Symbols:

TC: Total capacity (kW)
PI: Power input (kW)

Notes:

1. This table shows outdoor unit cooling capacity and power input.
2. □ Is specified point.
3. PI of indoor units is not included in the table.

5 Capacity tables

5 - 2 Heating capacity tables

RMXS140EV- Heating capacity													
Combination %	Outdoor air temp. °CDB	Indoor air temp.: °CDB											
		14 °C		16 °C		18 °C		19 °C		22 °C		24 °C	
		TC	PI	TC	PI	TC	PI	TC	PI	TC	PI	TC	PI
		kW	kW	kW	kW	kW	kW	kW	kW	kW	kW	kW	kW
90%	-15	8.14	3.28	8.16	3.41	8.17	3.54	8.18	3.61	8.18	3.68	8.19	3.84
	-11	9.27	3.40	9.26	3.54	9.25	3.68	9.24	3.76	9.23	3.83	9.21	4.00
	-7	10.46	3.54	10.42	3.68	10.39	3.83	10.37	3.92	10.34	4.00	10.30	4.18
	-3	11.71	3.68	11.65	3.84	11.59	4.00	11.56	4.09	11.53	4.18	11.46	4.37
	0	12.68	3.81	12.61	3.97	12.53	4.14	12.49	4.23	12.45	4.32	12.37	4.52
	2	13.35	3.89	13.26	4.06	13.17	4.24	13.13	4.33	13.08	4.43	12.99	4.63
	6	14.71	4.08	14.61	4.26	14.50	4.45	14.45	4.55	14.39	4.65	14.27	4.86
	10	16.12	4.29	16.00	4.48	15.88	4.68	15.81	4.78	15.75	4.89	15.61	5.12
80%	-15	7.04	2.94	7.06	3.06	7.07	3.19	7.08	3.26	7.08	3.33	7.09	3.48
	-11	8.11	3.04	8.10	3.17	8.09	3.31	8.08	3.38	8.08	3.46	8.06	3.62
	-7	9.23	3.16	9.20	3.30	9.16	3.44	9.15	3.52	9.13	3.60	9.09	3.77
	-3	10.39	3.28	10.34	3.43	10.29	3.59	10.26	3.67	10.24	3.75	10.17	3.93
	0	11.30	3.39	11.24	3.54	11.17	3.70	11.13	3.79	11.10	3.87	11.02	4.06
	2	11.92	3.46	11.85	3.62	11.77	3.78	11.73	3.87	11.69	3.96	11.60	4.16
	6	13.19	3.61	13.10	3.78	13.00	3.96	12.95	4.05	12.90	4.14	12.80	4.35
	10	14.50	3.78	14.39	3.96	14.28	4.14	14.22	4.24	14.16	4.34	14.04	4.56
70%	-15	6.05	2.53	6.06	2.64	6.08	2.76	6.08	2.82	6.09	2.89	6.10	3.03
	-11	7.03	2.62	7.02	2.74	7.02	2.87	7.01	2.94	7.01	3.01	7.00	3.16
	-7	8.06	2.73	8.03	2.85	8.00	2.99	7.99	3.06	7.97	3.13	7.94	3.29
	-3	9.13	2.84	9.08	2.98	9.04	3.12	9.01	3.20	8.99	3.27	8.93	3.44
	0	9.95	2.94	9.90	3.08	9.84	3.23	9.81	3.31	9.78	3.39	9.71	3.57
	2	10.52	3.00	10.45	3.15	10.38	3.30	10.35	3.38	10.31	3.47	10.24	3.65
	6	11.67	3.15	11.59	3.30	11.50	3.46	11.46	3.55	11.42	3.64	11.32	3.83
	10	12.86	3.30	12.76	3.47	12.66	3.64	12.61	3.73	12.56	3.82	12.45	4.02
60%	-15	5.17	2.05	5.18	2.15	5.19	2.25	5.20	2.31	5.20	2.37	5.22	2.49
	-11	6.04	2.14	6.04	2.25	6.03	2.36	6.03	2.42	6.02	2.48	6.02	2.61
	-7	6.96	2.24	6.93	2.36	6.91	2.48	6.90	2.54	6.88	2.61	6.86	2.75
	-3	7.90	2.36	7.87	2.48	7.82	2.61	7.80	2.68	7.78	2.75	7.74	2.90
	0	8.64	2.46	8.59	2.59	8.53	2.72	8.51	2.79	8.48	2.86	8.42	3.02
	2	9.14	2.53	9.08	2.66	9.02	2.80	8.99	2.87	8.96	2.95	8.89	3.11
	6	10.15	2.68	10.08	2.82	10.00	2.97	9.97	3.05	9.93	3.12	9.85	3.29
	10	11.20	2.85	11.11	3.00	11.02	3.16	10.98	3.24	10.94	3.32	10.84	3.50
50%	-15	4.40	1.55	4.41	1.63	4.42	1.72	4.43	1.77	4.43	1.81	4.45	1.91
	-11	5.14	1.64	5.14	1.73	5.14	1.83	5.13	1.87	5.13	1.92	5.12	2.03
	-7	5.92	1.74	5.90	1.84	5.88	1.95	5.87	2.00	5.86	2.05	5.84	2.17
	-3	6.73	1.87	6.70	1.97	6.66	2.09	6.64	2.14	6.62	2.20	6.59	2.32
	0	7.35	1.97	7.31	2.08	7.26	2.21	7.24	2.26	7.22	2.32	7.17	2.45
	2	7.78	2.05	7.73	2.17	7.67	2.29	7.65	2.35	7.62	2.41	7.57	2.54
	6	8.64	2.22	8.58	2.35	8.51	2.48	8.48	2.54	8.44	2.61	8.38	2.75
	10	9.53	2.42	9.45	2.55	9.37	2.69	9.33	2.76	9.29	2.83	9.22	2.97

3D052909

Symbols:
 TC: Total capacity (kW)
 PI: Power input (kW)

Notes:
 1. This table shows outdoor unit cooling capacity and power input.
 2. [] Is specified point.
 3. PI of indoor units is not included in the table.

5 Capacity tables

5 - 2 Heating capacity tables

RMXS160EV- Heating capacity													
Combination %	Outdoor air temp. °CDB	Indoor air temp.: °CDB											
		14 °C		16 °C		18 °C		19 °C		22 °C		24 °C	
		TC kW	PI kW	TC kW	PI kW	TC kW	PI kW	TC kW	PI kW	TC kW	PI kW	TC kW	PI kW
130%	-15	10.04	4.02	10.07	4.14	10.10	4.27	10.11	4.34	10.12	4.41	10.14	4.57
	-11	11.34	4.10	11.34	4.23	11.34	4.37	11.34	4.44	11.33	4.52	11.32	4.69
	-7	12.74	4.19	12.72	4.33	12.69	4.48	12.67	4.56	12.66	4.64	12.61	4.83
	-3	14.24	4.28	14.19	4.43	14.13	4.60	14.10	4.69	14.07	4.78	14.01	4.97
	0	15.42	4.36	15.35	4.52	15.27	4.70	15.23	4.79	15.19	4.88	15.11	5.09
	2	16.22	4.42	16.14	4.59	16.06	4.77	16.01	4.86	15.97	4.96	15.87	5.18
	6	17.90	4.54	17.79	4.72	17.68	4.92	17.63	5.02	17.57	5.13	17.45	5.36
	10	19.64	4.69	19.51	4.85	19.38	5.09	19.32	5.20	19.25	5.31	19.11	5.56
	12	20.53	4.77	20.40	4.97	20.26	5.18	20.19	5.29	20.12	5.31	19.96	5.66
15	21.90	4.89	21.76	5.10	21.60	5.33	21.52	5.45	21.44	5.57	21.27	5.83	
120%	-15	10.13	3.97	10.15	4.09	10.18	4.23	10.19	4.30	10.20	4.38	10.21	4.54
	-11	11.41	4.07	11.41	4.20	11.40	4.35	11.40	4.43	11.39	4.51	11.38	4.69
	-7	12.79	4.18	12.76	4.33	12.73	4.49	12.71	4.57	12.69	4.66	12.64	4.85
	-3	14.26	4.30	14.21	4.47	14.15	4.64	14.11	4.73	14.08	4.83	14.01	5.03
	0	15.42	4.41	15.34	4.58	15.26	4.76	15.22	4.86	15.18	4.96	15.08	5.18
	2	16.21	4.48	16.12	4.66	16.03	4.85	15.98	4.95	15.93	5.06	15.83	5.28
	6	17.85	4.65	17.74	4.84	17.62	5.05	17.56	5.15	17.50	5.27	17.37	5.51
	10	19.55	4.84	19.42	5.01	19.28	5.26	19.21	5.38	19.14	5.50	18.99	5.75
	12	20.42	4.94	20.28	5.16	20.14	5.38	20.06	5.50	19.99	5.52	19.82	5.89
15	21.76	5.11	21.61	5.33	21.45	5.57	21.36	5.69	21.28	5.82	21.10	6.10	
110%	-15	10.14	4.00	10.17	4.13	10.19	4.27	10.20	4.35	10.21	4.43	10.22	4.60
	-11	11.42	4.11	11.41	4.26	11.40	4.41	11.40	4.49	11.39	4.58	11.37	4.76
	-7	12.79	4.24	12.76	4.39	12.72	4.56	12.70	4.65	12.68	4.74	12.63	4.93
	-3	14.25	4.38	14.19	4.55	14.12	4.73	14.09	4.82	14.05	4.92	13.98	5.13
	0	15.39	4.49	15.31	4.67	15.23	4.86	15.18	4.96	15.14	5.07	15.04	5.29
	2	16.17	4.58	16.08	4.77	15.99	4.96	15.94	5.06	15.89	5.17	15.78	5.40
	6	17.79	4.76	17.68	4.97	17.56	5.17	17.50	5.29	17.44	5.40	17.31	5.64
	10	19.47	4.97	19.34	5.16	19.20	5.41	19.13	5.53	19.06	5.65	18.91	5.91
	12	20.34	5.09	20.19	5.31	20.05	5.54	19.97	5.66	19.89	5.69	19.73	6.06
15	21.66	5.27	21.50	5.51	21.34	5.75	21.26	5.88	21.17	6.01	20.46	6.16	
100%	-15	10.09	4.13	10.11	4.26	10.14	4.41	10.15	4.48	10.15	4.56	10.17	4.73
	-11	11.36	4.24	11.36	4.38	11.35	4.54	11.34	4.62	11.34	4.71	11.32	4.89
	-7	12.73	4.36	12.70	4.52	12.66	4.69	12.64	4.78	12.62	4.87	12.57	5.07
	-3	14.18	4.50	14.13	4.67	14.06	4.85	14.03	4.95	14.00	5.05	13.93	5.26
	0	15.33	4.61	15.25	4.80	15.17	4.99	15.13	5.09	15.08	5.19	14.99	5.42
	2	16.11	4.69	16.02	4.89	15.92	5.09	15.88	5.19	15.83	5.30	15.73	5.53
	6	17.73	4.88	17.61	5.09	17.50	5.30	17.44	5.41	17.38	5.52	17.26	5.77
	10	19.41	5.08	19.27	5.31	19.14	5.54	19.07	5.65	19.00	5.78	18.85	6.04
	12	20.28	5.19	20.13	5.43	19.99	5.66	19.91	5.79	19.84	5.91	19.63	6.16
15	21.60	5.38	21.44	5.63	21.28	5.87	21.20	6.00	21.12	6.13	20.20	6.16	

3D052910

Symbols:

TC: Total capacity (kW)
PI: Power input (kW)

Notes:

1. This table shows outdoor unit cooling capacity and power input.
2. □ Is specified point.
3. PI of indoor units is not included in the table.

5 Capacity tables

5 - 2 Heating capacity tables

RMXS160EV- Heating capacity													
Combination %	Outdoor air temp. °CDB	Indoor air temp.: °CDB											
		14 °C		16 °C		18 °C		19 °C		22 °C		24 °C	
		TC kW	PI kW	TC kW	PI kW	TC kW	PI kW	TC kW	PI kW	TC kW	PI kW	TC kW	PI kW
90%	-15	8,95	3,62	8,97	3,76	8,99	3,90	9,00	3,97	9,01	4,05	9,02	4,21
	-11	10,16	3,73	10,15	3,88	10,14	4,03	10,13	4,11	10,13	4,19	10,11	4,37
	-7	11,44	3,85	11,41	4,01	11,37	4,17	11,35	4,26	11,33	4,35	11,29	4,54
	-3	12,80	3,99	12,74	4,16	12,68	4,33	12,65	4,42	12,61	4,52	12,55	4,72
	0	13,86	4,10	13,78	4,28	13,70	4,46	13,66	4,56	13,62	4,65	13,53	4,87
	2	14,58	4,18	14,49	4,37	14,40	4,55	14,36	4,65	14,31	4,75	14,22	4,97
	6	16,08	4,35	15,97	4,55	15,86	4,75	15,80	4,86	15,75	4,96	15,62	5,19
	10	17,63	4,54	17,49	4,76	17,37	4,97	17,30	5,08	17,24	5,19	17,09	5,44
80%	-15	7,85	3,12	7,87	3,25	7,89	3,38	7,89	3,45	7,90	3,52	7,91	3,68
	-11	8,98	3,22	8,97	3,37	8,96	3,51	8,96	3,58	8,95	3,66	8,93	3,83
	-7	10,17	3,34	10,14	3,50	10,10	3,65	10,08	3,73	10,06	3,81	10,02	3,99
	-3	11,42	3,47	11,36	3,64	11,31	3,80	11,28	3,89	11,25	3,97	11,18	4,16
	0	12,39	3,58	12,32	3,76	12,25	3,93	12,21	4,01	12,17	4,11	12,09	4,30
	2	13,06	3,66	12,97	3,84	12,89	4,01	12,85	4,11	12,80	4,20	12,71	4,40
	6	14,42	3,82	14,32	4,02	14,22	4,20	14,16	4,30	14,11	4,40	14,00	4,62
	10	15,84	4,01	15,71	4,21	15,59	4,41	15,53	4,51	15,47	4,62	15,33	4,85
70%	-15	6,80	2,61	6,81	2,73	6,82	2,85	6,83	2,92	6,84	2,98	6,85	3,13
	-11	7,83	2,71	7,82	2,84	7,81	2,98	7,81	3,04	7,80	3,12	7,79	3,27
	-7	8,92	2,83	8,88	2,97	8,85	3,11	8,84	3,19	8,82	3,26	8,78	3,43
	-3	10,05	2,96	10,00	3,11	9,95	3,26	9,92	3,34	9,89	3,42	9,84	3,59
	0	10,93	3,06	10,86	3,22	10,80	3,38	10,76	3,46	10,73	3,55	10,66	3,73
	2	11,53	3,14	11,45	3,31	11,37	3,47	11,34	3,55	11,30	3,64	11,22	3,83
	6	12,76	3,30	12,67	3,48	12,57	3,65	12,53	3,74	12,48	3,83	12,37	4,03
	10	14,03	3,48	13,92	3,67	13,81	3,85	13,75	3,95	13,69	4,04	13,57	4,25
60%	-15	5,78	2,10	5,79	2,21	5,80	2,32	5,81	2,38	5,82	2,44	5,83	2,57
	-11	6,71	2,20	6,70	2,32	6,69	2,44	6,69	2,50	6,68	2,57	6,67	2,70
	-7	7,68	2,31	7,65	2,44	7,63	2,57	7,61	2,64	7,60	2,70	7,57	2,85
	-3	8,69	2,44	8,65	2,58	8,60	2,71	8,58	2,78	8,55	2,86	8,50	3,01
	0	9,48	2,55	9,42	2,69	9,36	2,83	9,33	2,91	9,30	2,98	9,23	3,15
	2	10,01	2,62	9,94	2,77	9,87	2,92	9,84	2,99	9,80	3,07	9,73	3,24
	6	11,10	2,79	11,01	2,94	10,93	3,10	10,89	3,18	10,85	3,26	10,76	3,44
	10	12,22	2,97	12,12	3,14	12,02	3,31	11,97	3,39	11,92	3,48	11,82	3,66
50%	-15	4,80	1,61	4,81	1,70	4,83	1,80	4,83	1,85	4,84	1,90	4,85	2,01
	-11	5,62	1,70	5,61	1,80	5,61	1,91	5,60	1,96	5,60	2,01	5,59	2,13
	-7	6,47	1,81	6,44	1,91	6,42	2,03	6,41	2,09	6,40	2,14	6,37	2,27
	-3	7,35	1,93	7,31	2,04	7,27	2,17	7,25	2,23	7,23	2,29	7,19	2,42
	0	8,03	2,04	7,98	2,16	7,93	2,29	7,90	2,35	7,88	2,41	7,82	2,55
	2	8,49	2,11	8,43	2,24	8,37	2,37	8,35	2,43	8,32	2,50	8,26	2,65
	6	9,43	2,28	9,36	2,41	9,29	2,55	9,25	2,62	9,22	2,69	9,14	2,85
	10	10,40	2,46	10,32	2,60	10,23	2,76	10,19	2,83	10,15	2,91	10,06	3,07

3D052910

Symbols:
TC: Total capacity (kW)
PI: Power input (kW)

Notes:
1. This table shows outdoor unit cooling capacity and power input.
2. □ Is specified point.
3. PI of indoor units is not included in the table.

5 Capacity tables

5 - 3 Capacity correction factor

Capacity correction factor by the length of refrigerant piping (Reference) Rate of change in capacity by the main piping length

Rate of change in cooling capacity

Main piping length	5	10	15	20	25	30	35	40	45	50	55
Rate of change in cooling capacity	100.0%	98.6%	97.2%	95.9%	94.7%	93.5%	92.3%	91.2%	90.1%	89.1%	88.1%

Rate of change in heating capacity

Main piping length	5	10	15	20	25	30	35	40	45	50	55
Rate of change in heating capacity	100.0%	99.5%	99.1%	98.6%	98.2%	97.7%	97.3%	96.9%	96.4%	96.0%	95.6%

Rate of change in capacity by the main piping length

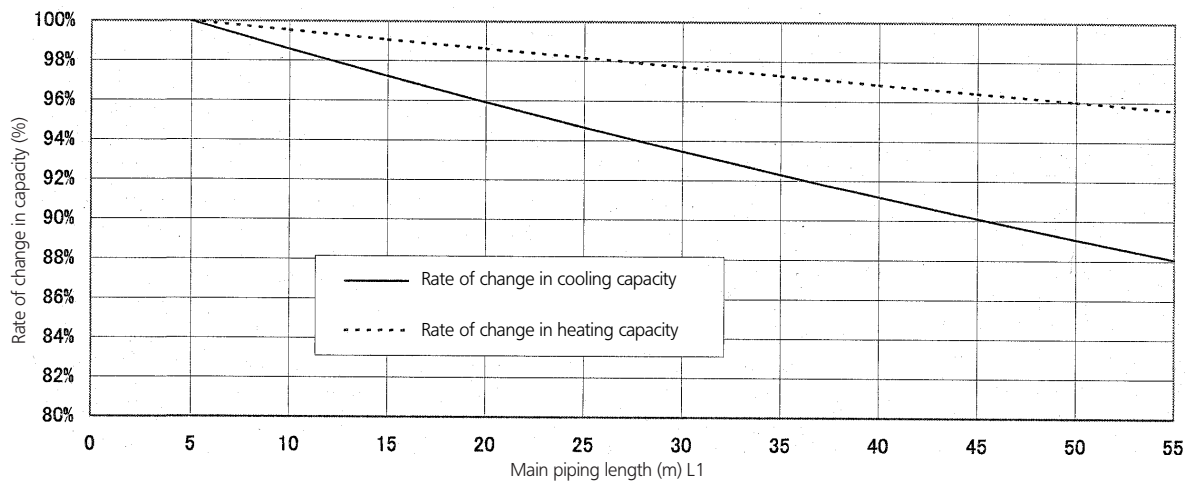

In both cases, the outdoor unit is in inferior or superior position for the indoor unit, the rate of change in capacity is the same.

Rate of change in capacity by the branch piping length

(1) Refrigerant piping connection diameter
liquid ϕ 6.4
gas ϕ 15.9

Piping length	Rate of change in capacity	
	Cooling	Heating
3	100.0%	100.0%
5	99.6%	99.9%
10	98.7%	99.6%
15	97.9%	99.3%

(2) Refrigerant piping connection diameter
liquid ϕ 6.4
gas ϕ 12.7

Piping length	Rate of change in capacity	
	Cooling	Heating
3	100.0%	100.0%
5	99.1%	99.5%
10	96.9%	98.2%
15	94.8%	97.0%

(3) Refrigerant piping connection diameter
liquid ϕ 6.4
gas ϕ 9.5

Piping length	Rate of change in capacity	
	Cooling	Heating
3	100.0%	100.0%
5	98.0%	98.8%
10	93.4%	96.0%
15	89.3%	93.5%

Piping size for field connection (mm)

KW		RA		SA	
		liquid	gas	liquid	gas
	25	ϕ 6.4	ϕ 9.5	ϕ 6.4	ϕ 9.5
	35				
	50				
	60				
	71				
			ϕ 12.7		ϕ 15.9
			ϕ 15.9	ϕ 9.5	

Notes

- These figures illustrate the rate of change in capacity of a standard indoor unit system at maximum load (with the thermostat set to maximum) under standard conditions. Moreover, under partial load conditions there is only a minor deviation from the rate of change in capacity shown in the above figures.
- With this outdoor unit, evaporating pressure constant control when cooling, and condensing pressure constant control when heating is carried out.

System layout of piping

Piping length: L1 = 5m L2 = 3m

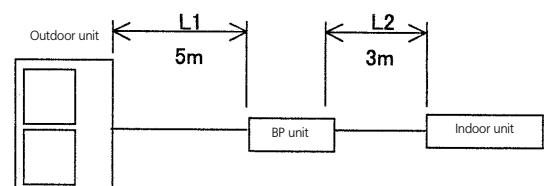

35
5

5 Capacity tables

5 - 3 Capacity correction factor

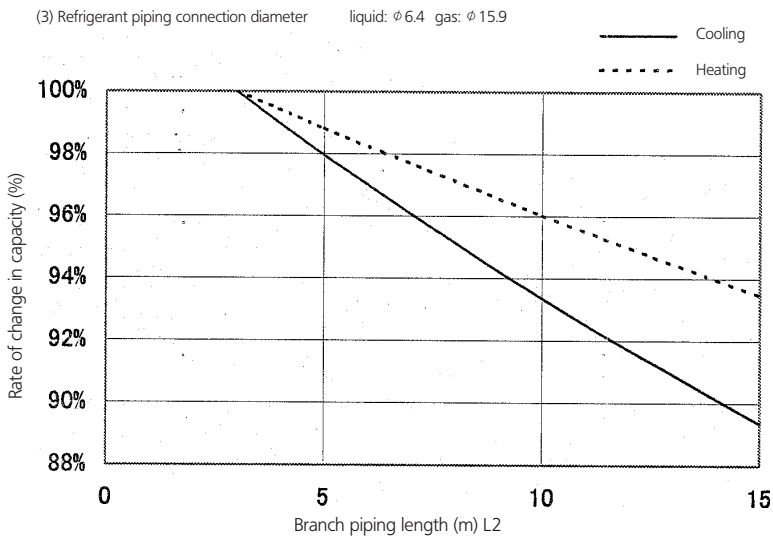
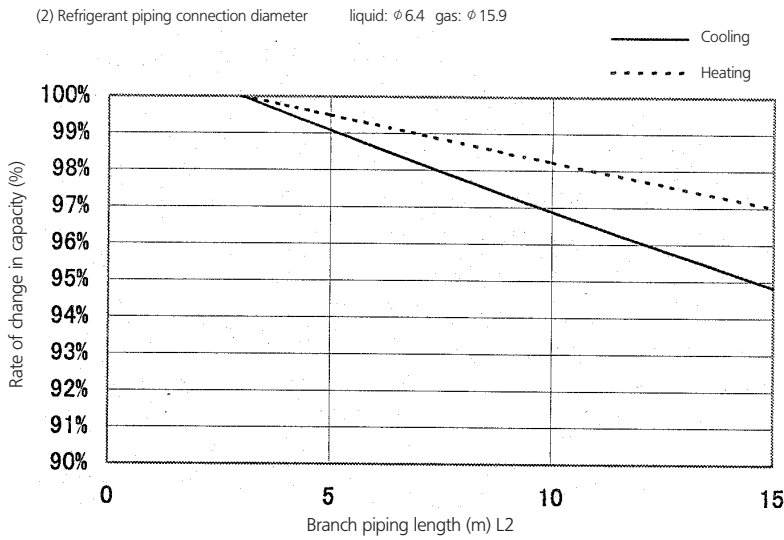
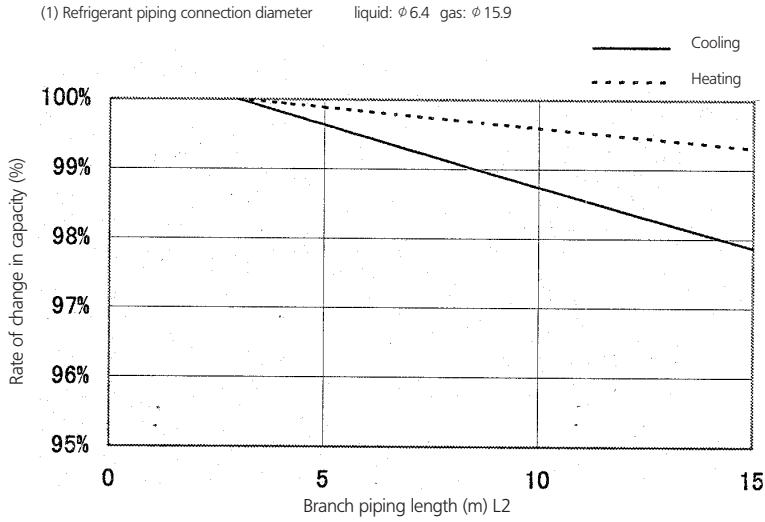

Method of calculating cooling / heating capacity:
 Total capacity from capacity tables x (Rate of change in capacity by main piping length x rate of change in capacity by branch piping length).

6 Dimensional drawing & centre of gravity

6 - 1 Dimensional drawing

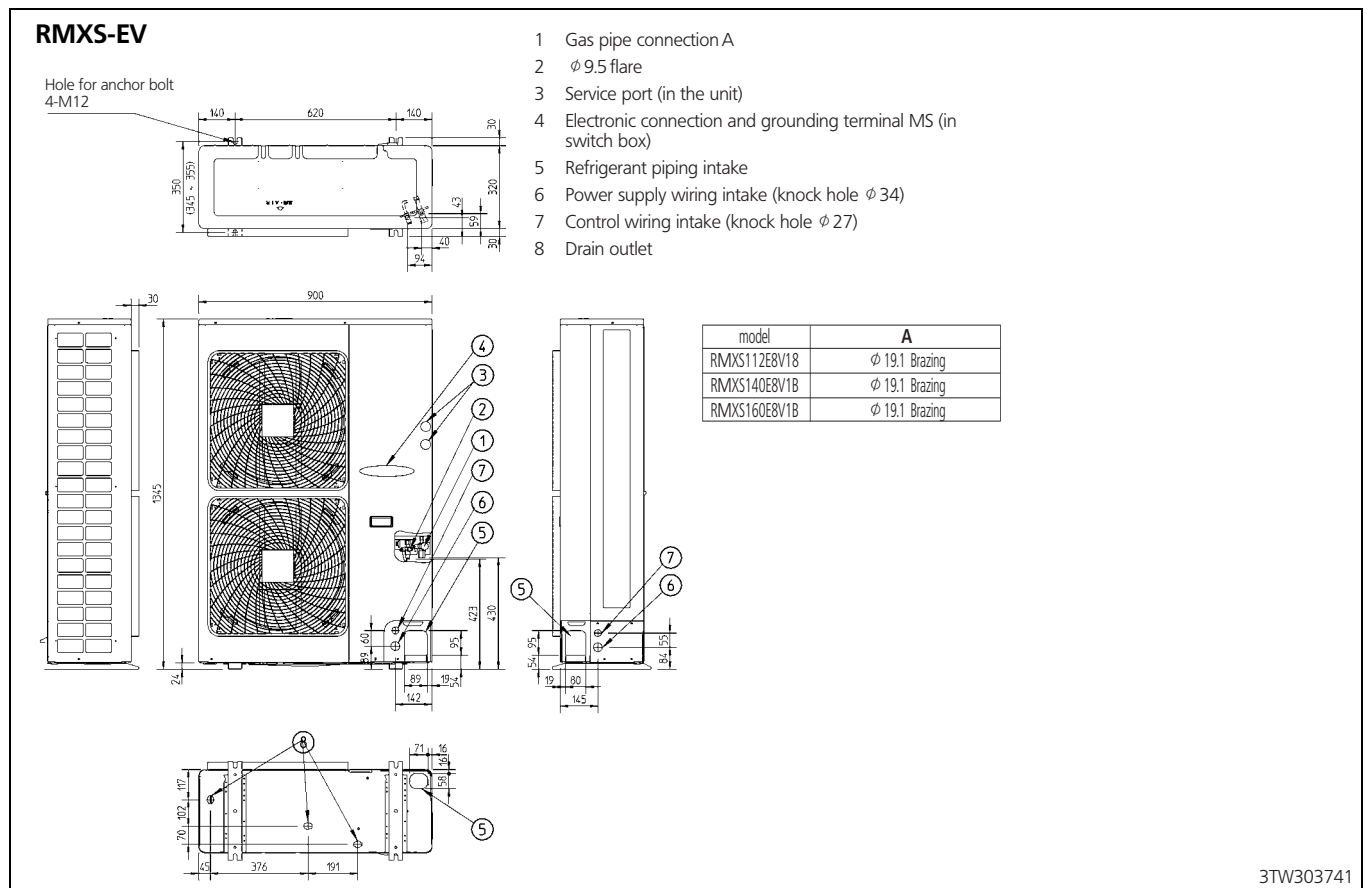

6 Dimensional drawing & centre of gravity

6 - 2 Centre of gravity

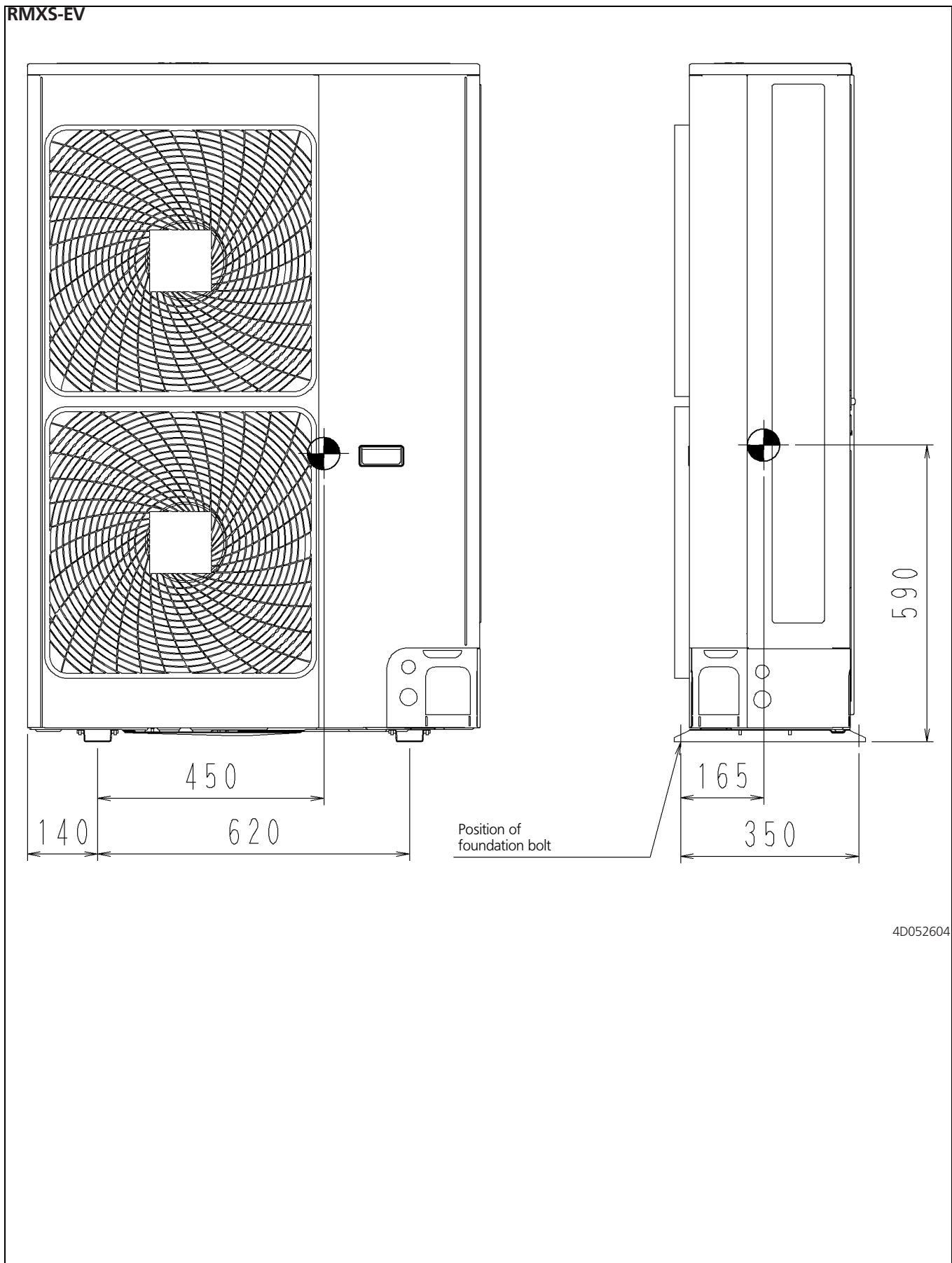

7 Piping diagram

RMXS-EV

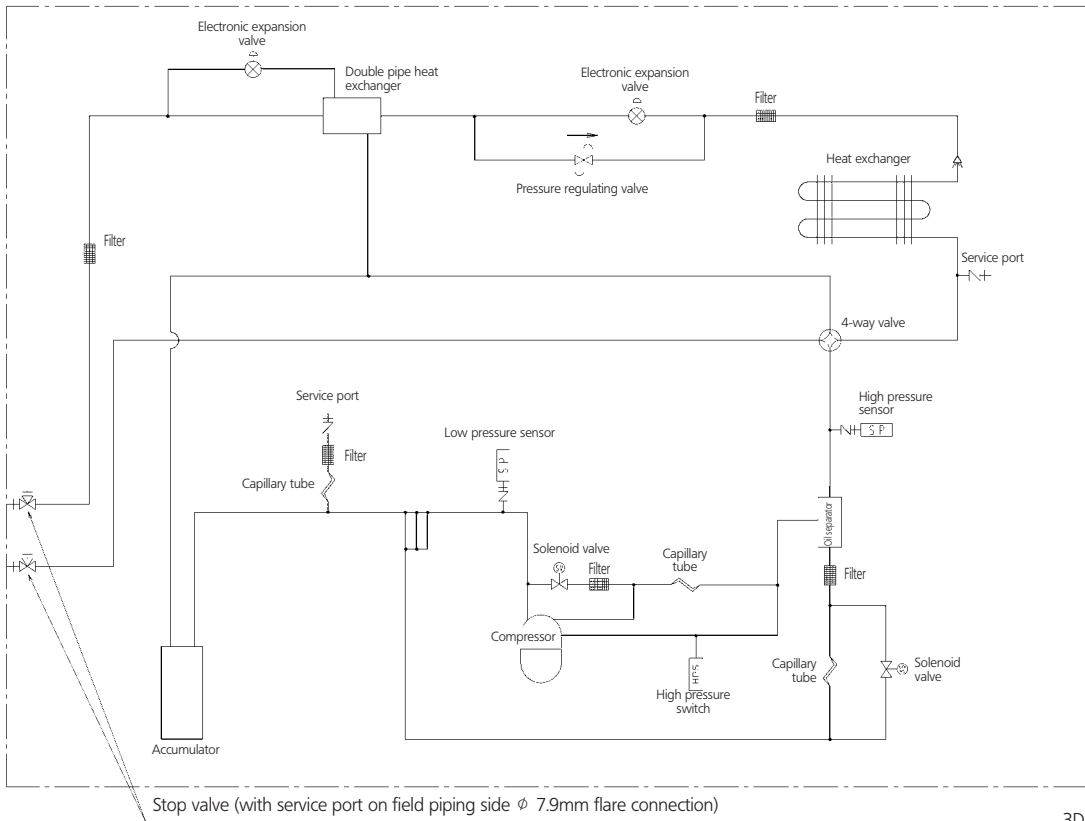

3D052712

35
7

8 Wiring diagram

8 - 1 Wiring diagram

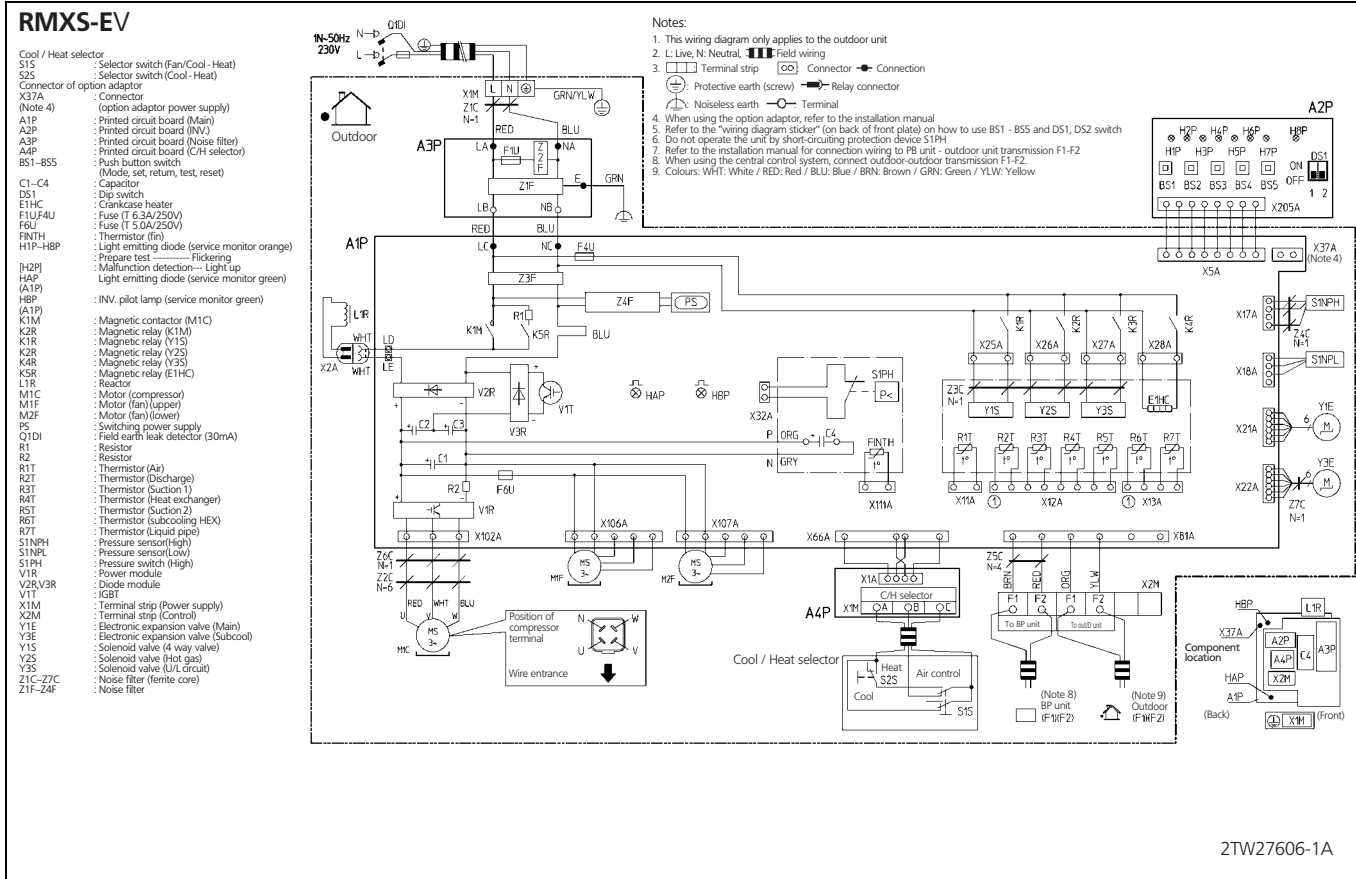

8 Wiring diagram

8 - 2 External connection diagram

RMXS112-160EV

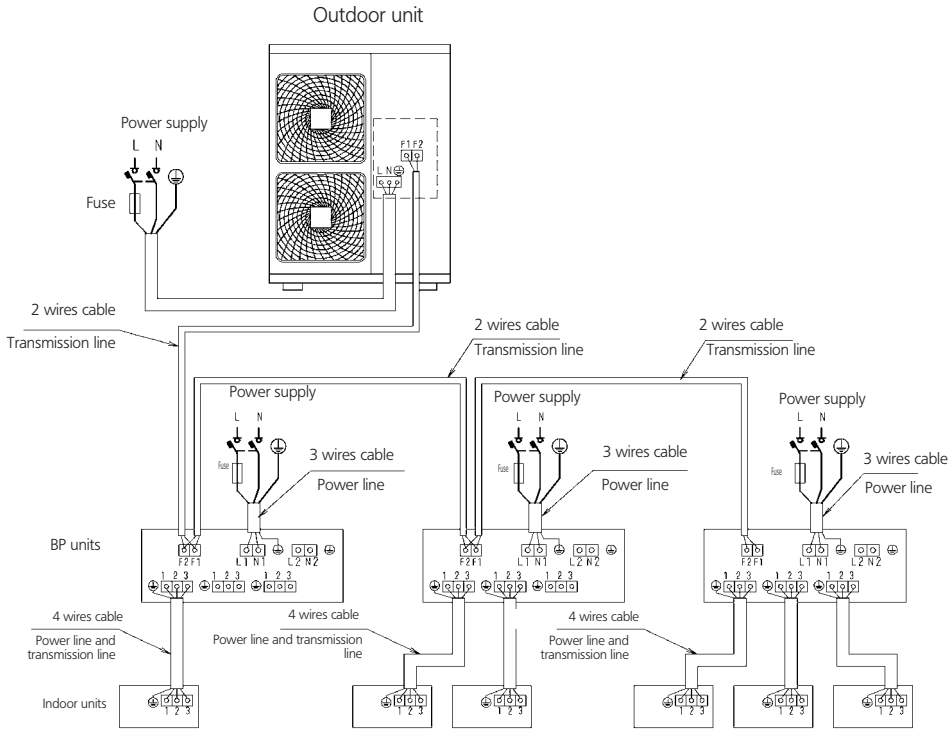

NOTES

- 1 All wiring, components and materials to be produced on the site must comply with the applicable local and national codes.
- 2 Use copper conductors only.
- 3 See wiring diagrams for details.
- 4 Install circuit breakers for safety.
- 5 All field wiring and components must be installed by a licensed electrician.
- 6 Units shall be grounded in compliance with applicable local national codes.
- 7 Wiring shown are general points-of-connection guides only and are not intended for or to include all details for a specific installation.
- 8 Be sure to install the switch and the fuse to the power line of each equipment.

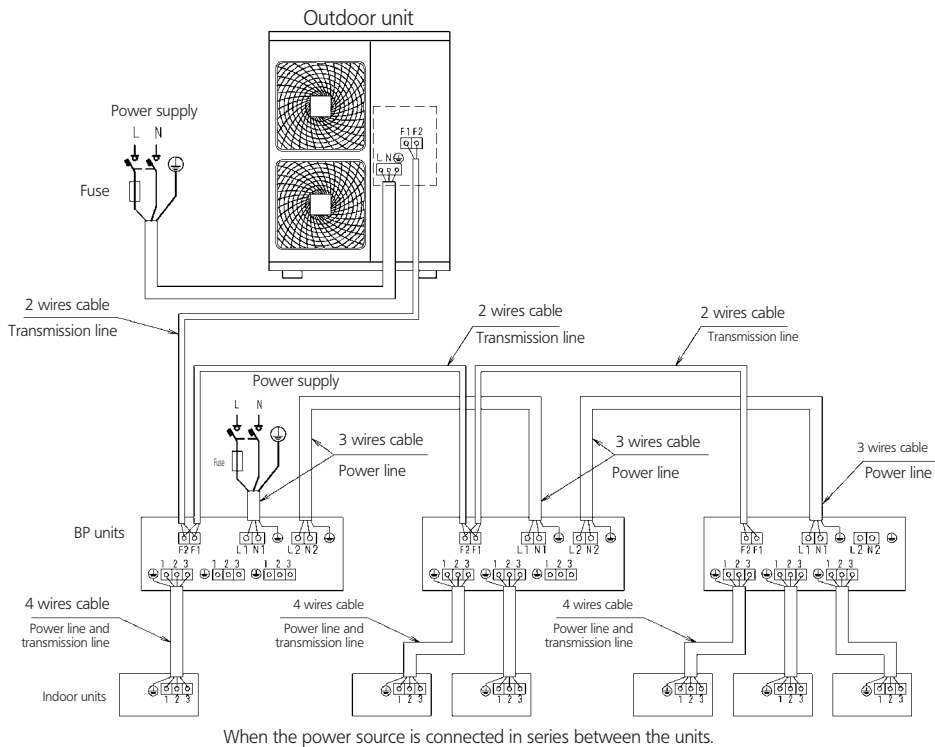

9 Sound data

9 - 1 Sound pressure spectrum

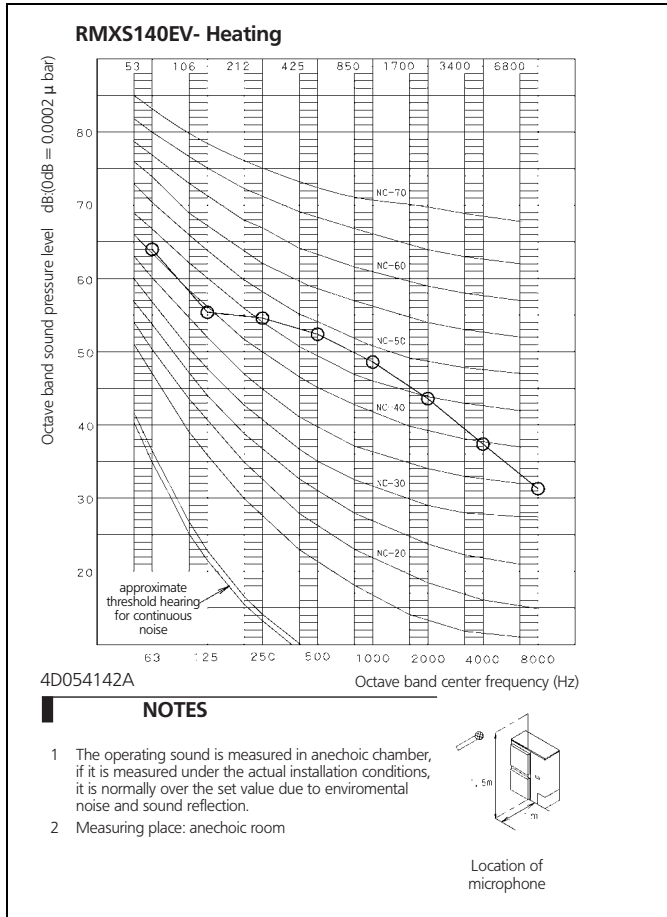
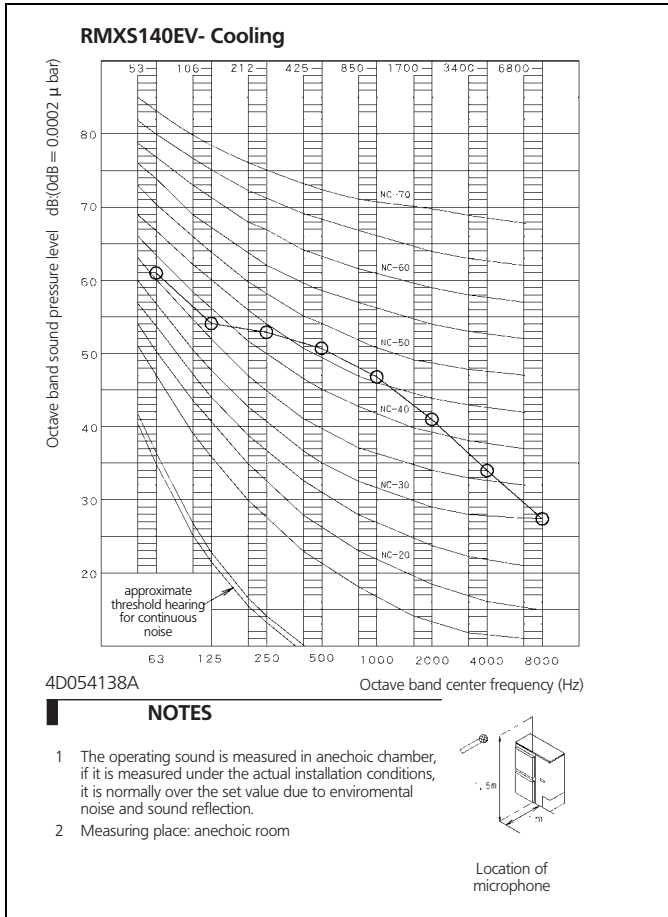
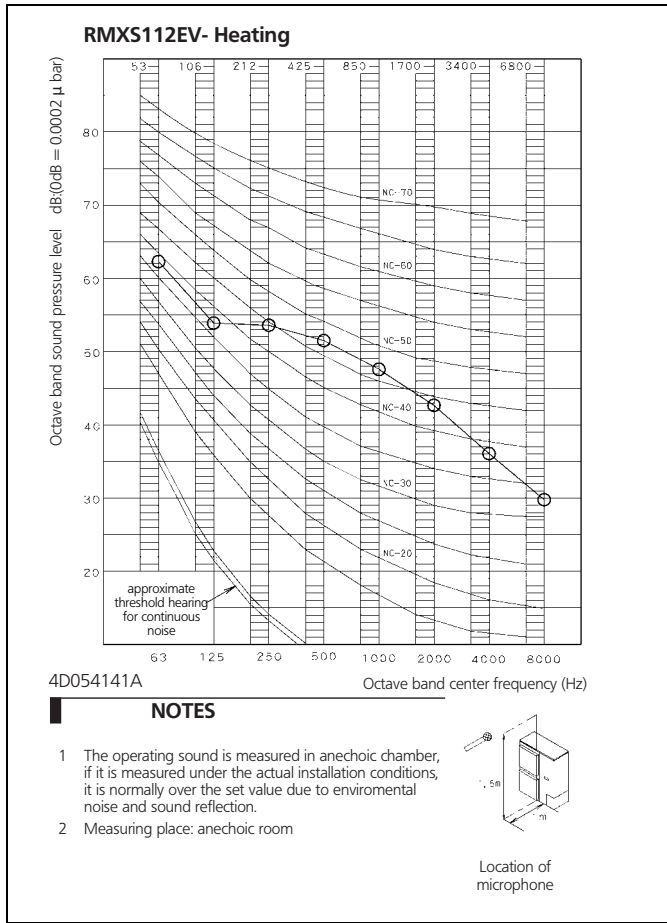
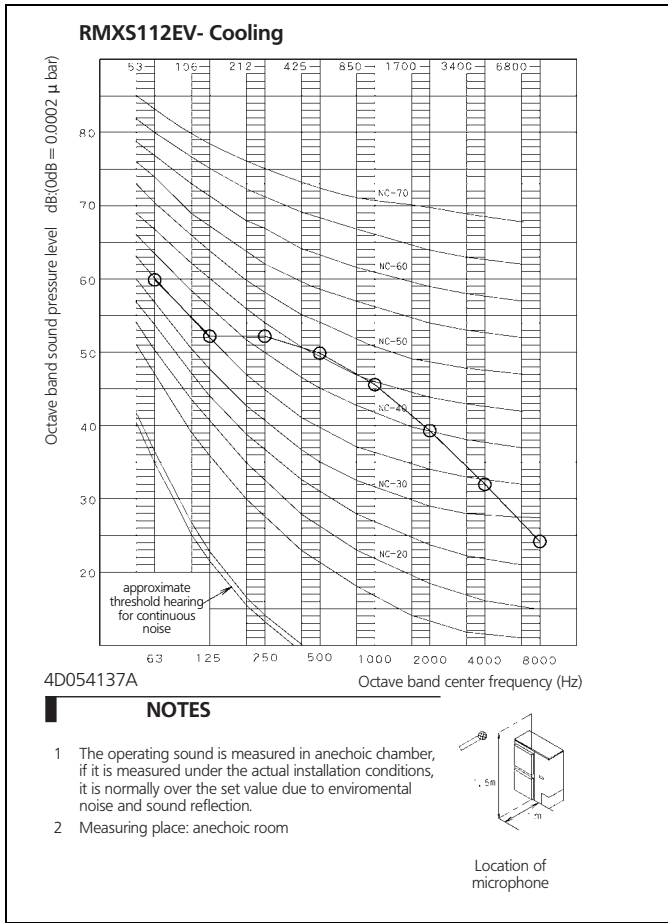

9 Sound data

9 - 1 Sound pressure spectrum

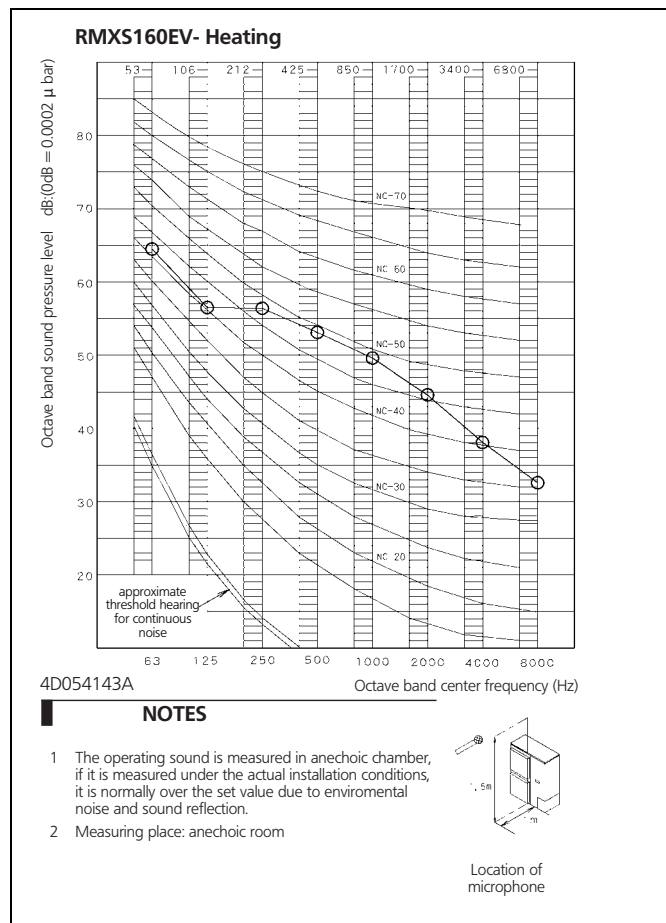
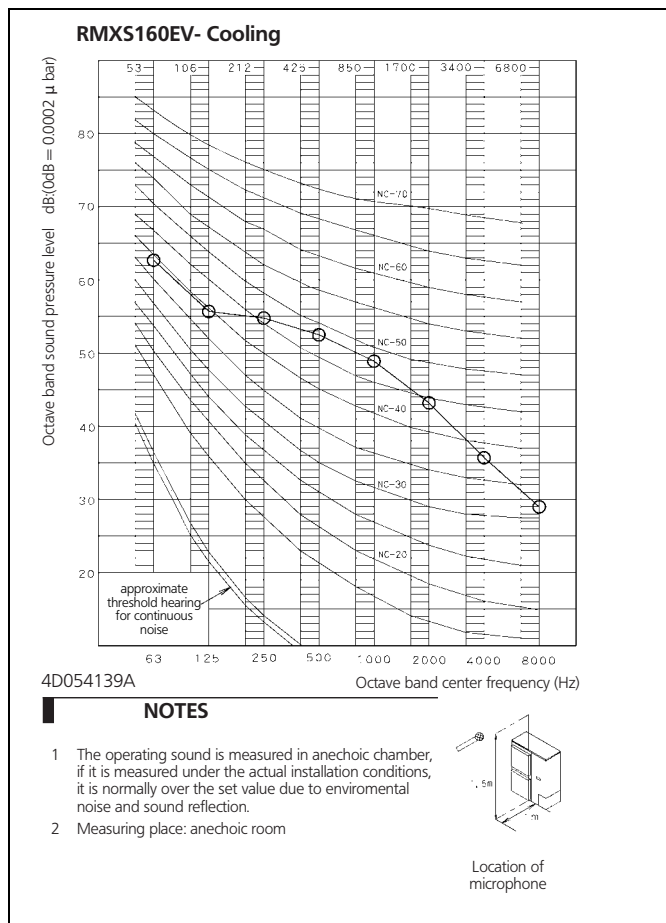

35

9

9 Sound data

9 - 2 Sound power spectrum

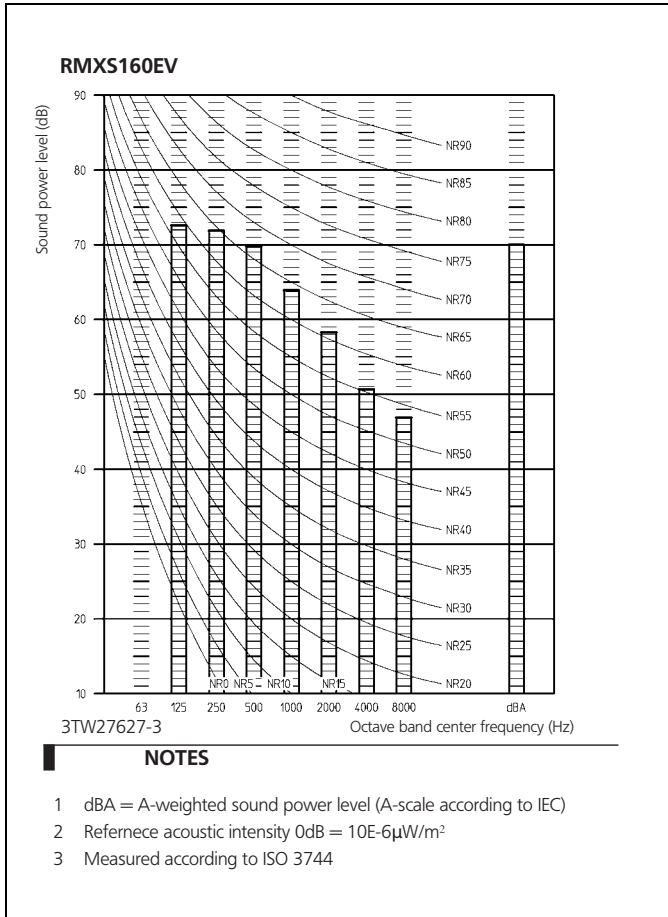
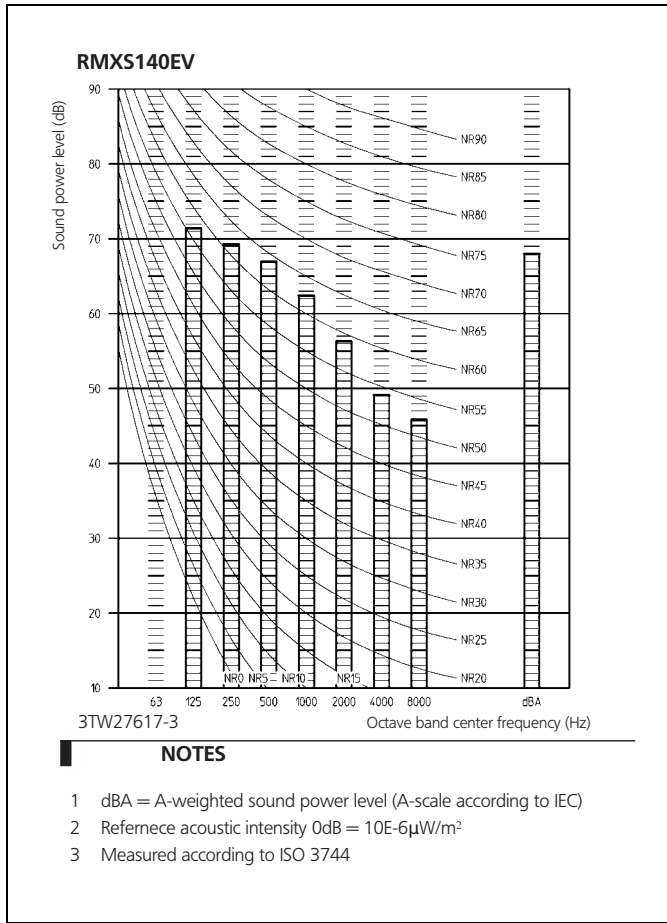
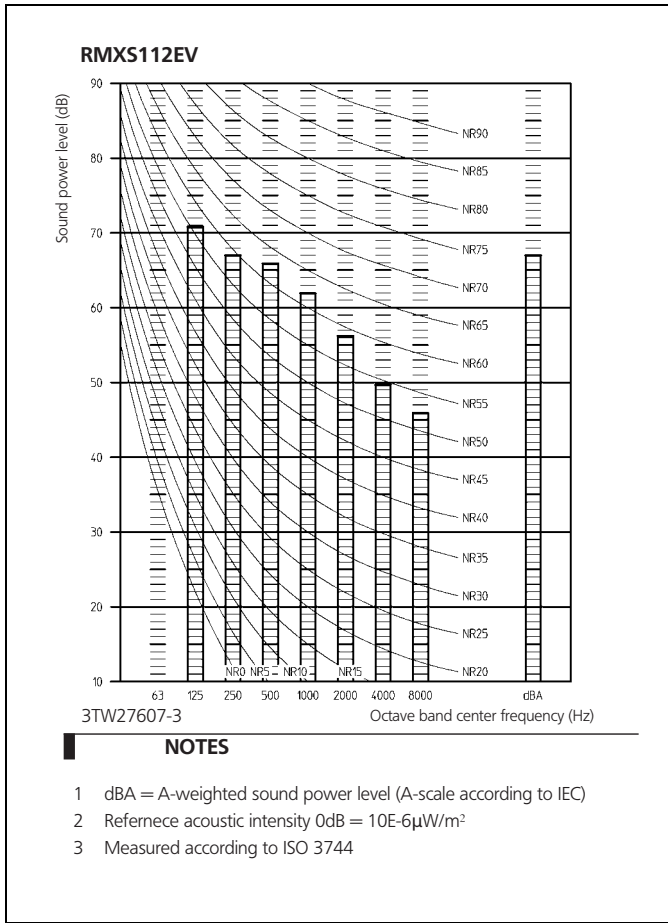

10 Installation

10 - 1 Installation method

Required installation space

The unit of the values is mm.

1. Where there is an obstacle on the suction side

(a) No obstacle above

- 1 Stand-alone installation
 - Obstacle on the suction side only.

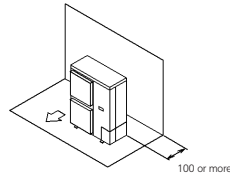

- Obstacle on both sides.

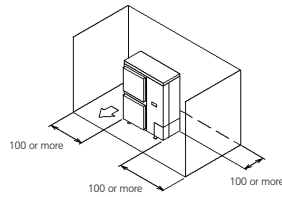

- 2 Series installation (2 or more).

- Obstacle on both sides

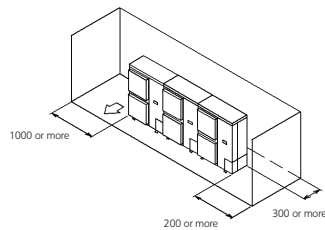

(b) Obstacle above, too.

- 1 Stand-alone installation
 - Obstacle on the suction side,

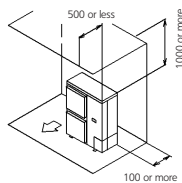

- Obstacle on the suction side and both sides.

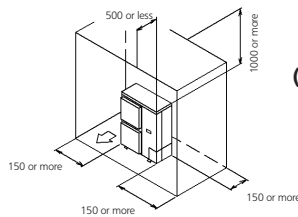

- 2 Series installation (2 or more).

- Obstacle on the suction side and both sides.

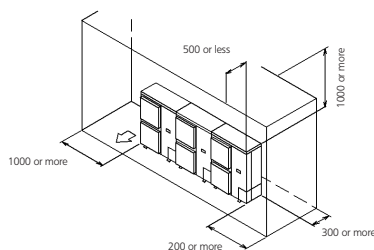

(2) Where there is an obstacle on the discharge side

(a) No obstacle above

- (1) Stand-alone installation

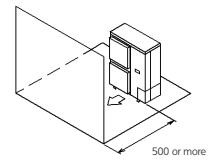

- (2) Series installation (2 or more)

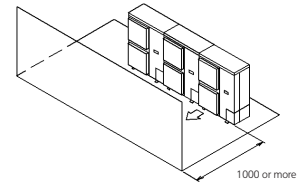

(b) Obstacle above, too.

- 1 Stand-alone installation

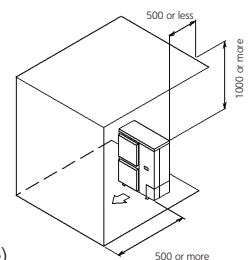

- 2 Series installation (2 or more).

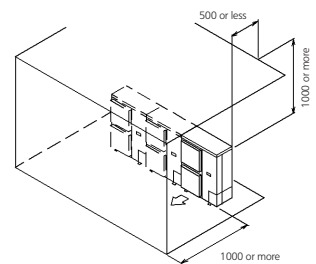

3. Where there are obstacles on both suction and discharge sides:

Pattern 1

Where the obstacles on the discharge side is higher than the unit.
(There is no height limit for obstructions on the intake side.)

(a) No obstacle above.

- 1 Stand-alone installation.

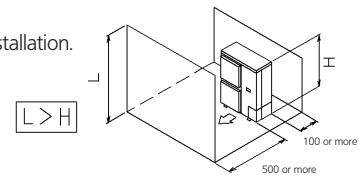

- 2 Series installation (2 or more).

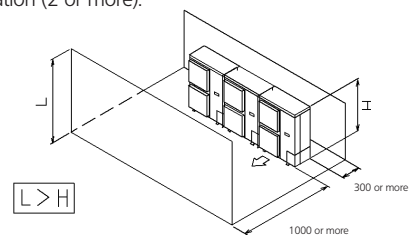

10 Installation

10 - 1 Installation method

(b) Obstacle above, too

1 Stand-alone installation.

The relations between H, A and L are as follows.

	L	A
$L \leq H$	$0 < L \leq 1/2 H$	750
	$1/2 H < L \leq H$	1000
$H < L$	Set the stand as : $L \leq H$	

Close the bottom of the installation frame to prevent the discharged air from being bypassed.

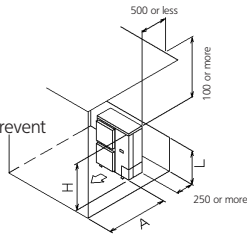

2 Series installation (2 or more).

The relations between H, A and L are as follows.

	L	A
$L \leq H$	$0 < L \leq 1/2 H$	1000
	$1/2 H < L \leq H$	1250
$H < L$	Set the stand as : $L \leq H$	

Close the bottom of the installation frame to prevent the discharged air from being bypassed.

Only two units can be installed for this series.

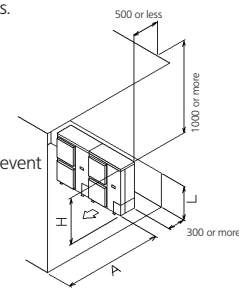

Pattern 2

Where the obstacle on the discharge side is lower than the unit.
(There is no height limit for obstructions on the intake side.)

(a) No obstacle above.

1 Stand-alone installation.

$$L \leq H$$

2 Series installation (2 or more).

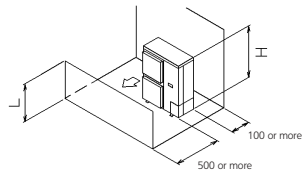

The relations between H, A and L are as follows.

	L	A
$L \leq H$	$0 < L \leq 1/2 H$	250
	$1/2 H < L \leq H$	300

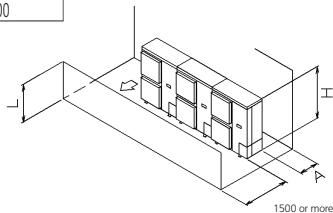

(b) Obstacle above, too.

1 Stand-alone installation.

The relations between H, A and L are as follows.

	L	A
$L \leq H$	$0 < L \leq 1/2 H$	100
	$1/2 H < L \leq H$	200
$H < L$	Set the stand as : $L \leq H$	

Close the bottom of the installation frame to prevent the discharged air from being bypassed.

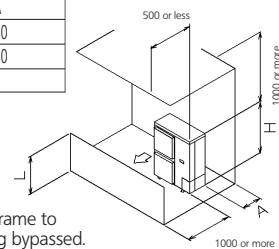

1 Series installation.

The relations between H, A and L are as follows.

	L	A
$L \leq H$	$0 < L \leq 1/2 H$	250
	$1/2 H < L \leq H$	300
$H < L$	Set the stand as : $L \leq H$	

Close the bottom of the installation frame to prevent the discharged air from being bypassed.

Only two units can be installed for this series.

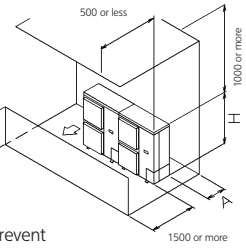

4. Double-decker installation

(a) Obstacle on the discharge side.

Close the gap A (the gap between the upper and lower outdoor units) to prevent the discharged air from being bypassed.

Do not stack more than two unit.

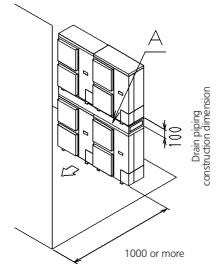

(b) Obstacle on the suction side only.

Close the gap A (the gap between the upper and lower outdoor units) to prevent the discharged air from being bypassed.

Do not stack more than one unit.

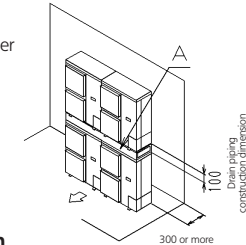

5. Multiple rows of series installation (on the rooftop, etc.).

(a) One row of stand-alone installation.

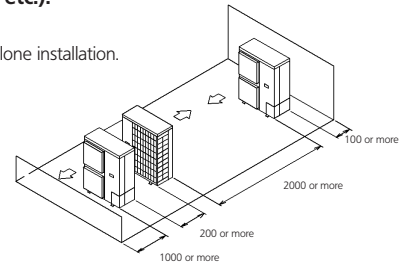

(b) Rows of series installation (2 or more).

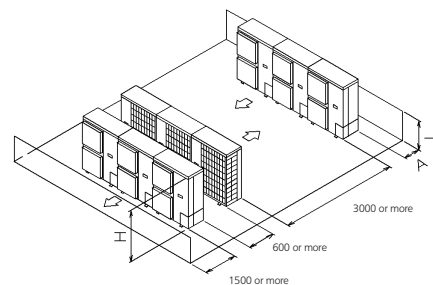

The relations between H, A and L are as follows.

	L	A
$L \leq H$	$0 < L \leq 1/2 H$	250
	$1/2 H < L \leq H$	300
$H < L$	Cannot be installed	

3D049376B

11 Operation range

RMXS-EV

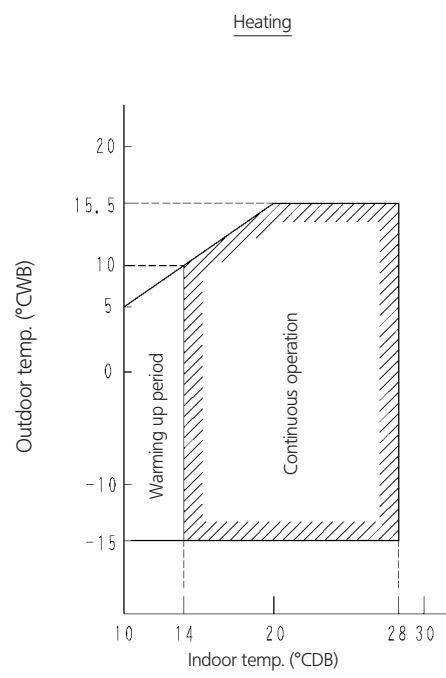
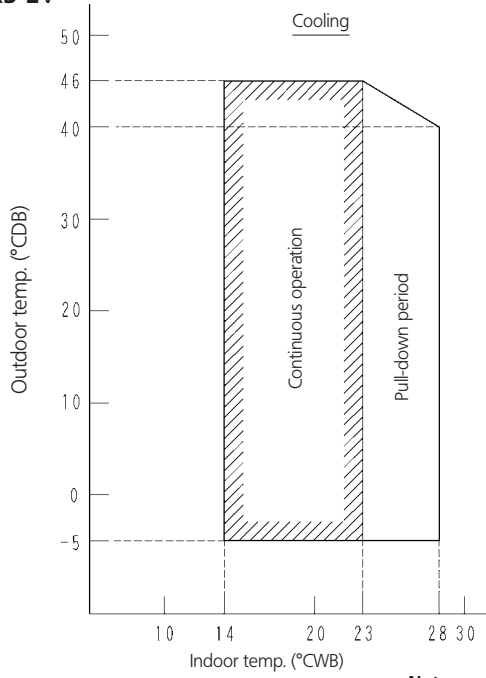

Notes:

The graphs are based on the following conditions:

- Equivalent piping length

From outdoor unit to BP unit

5 m

Total from BP unit to indoor unit

3 m

- Level difference

0 m

- Air flow rate

high

3D049096C

35

11