



technical data

FBQ-B7



**Concealed Ceiling,
Inverter Controlled Unit**



air conditioning systems

Split Sky Air

Split - Sky Air



ISO14001 assures an effective environmental management system in order to help protect human health and the environment from the potential impact of our activities, products and services and to assist in maintaining and improving the quality of the environment



Daikin units comply with the European regulations that guarantee the safety of the product.



Daikin Europe N.V. is approved by LRQA for its Quality Management System in accordance with the ISO9001 standard. ISO9001 pertains to quality assurance regarding design, development, manufacturing as well as to services related to the product.



Daikin Europe N.V. is participating in the EUROVENT Certification Programme. Products are as listed in the EUROVENT Directory of Certified Products.

Specifications are subject to change without prior notice.

DAIKIN EUROPE N.V.

Zandvoordestraat 300
B - 8400 Ostend Belgium
Internet: <http://www.daikineurope.com>

TABLE OF CONTENTS

FBQ-B7



1	Features	2
2	Specifications	3
	Nominal capacity, capacity steps and nominal input	
	Technical specifications	
3	Dimensional drawings	6
4	Piping diagrams	9
5	Wiring diagrams	10
6	Sound level	12
	Sound level data	
	Sound pressure spectrum	
7	Fan characteristics	13
8	Accessories	14
	Optional accessories	
9	Control systems	16
10	Center of gravity	17
11	Safety device settings	17
12	Installation	18

* For capacity tables, please refer to part II: outdoor units





1 Features

1

- Lightweight and compact
 - Blends unobtrusively with any interior décor
 - Fits flush into each ceiling
 - Extremely quiet in operation both indoors and outdoors
 - The position of the individual air discharge grilles can be altered, enabling a uniform temperature, even in irregularly shaped rooms: L-shaped room, U-shaped room, long room
 - Up to 4 indoor units can be connected to 1 Multi outdoor unit. All indoor units are individually controllable with remote control and do not need to be installed in the same room.
 - The wired remote control has a programmable timer
- The wired remote control has following features:
 - A real time clock
 - A schedule timer:
 - Possibility to program a weekly schedule timer.
 - Possibility to program 5 actions for each day of the week.
 - Limit operation (min./max.): room temperature is controlled within adjustable upper and lower limits.
 - Home leave (frost protection): during absence, the indoor temperature can be maintained at a certain level. This function can also switch the unit ON/OFF.

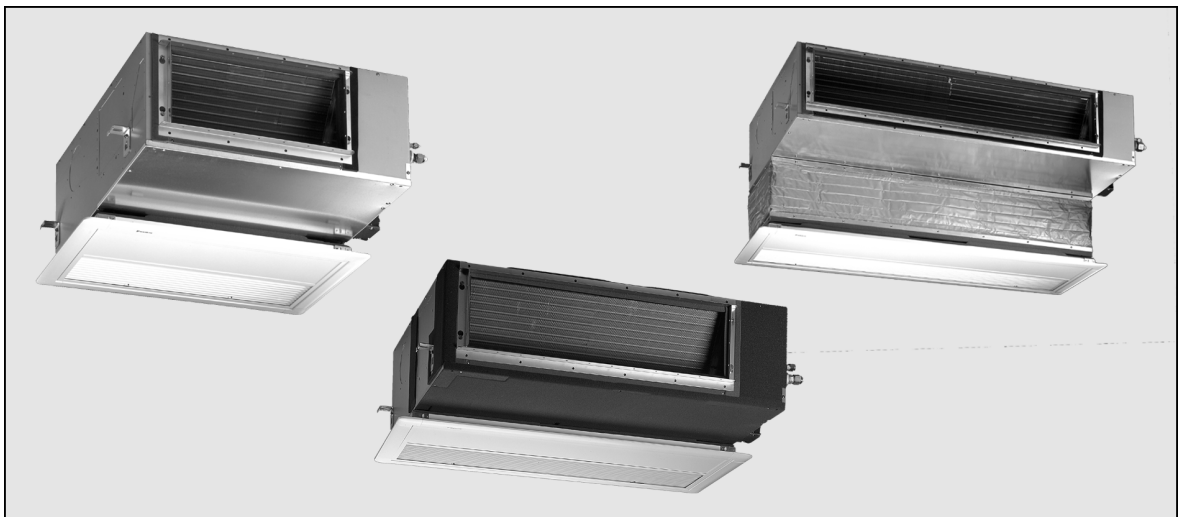

Optional



2 steps



Standard



35-60



35-60



2 Specifications



NOMINAL CAPACITY and NOMINAL INPUT					
For indoor units only:					
INDOOR UNITS			FBQ35B7V1	FBQ50B7V1	FBQ60B7V1
NOMINAL INPUT	Cooling	kW	-	-	-
	Heating	kW	-	-	-

For combination indoor + outdoor units (air cooled):								
INDOOR UNITS			FBQ35B7V1	FBQ50B7V1	FBQ60B7V1	FBQ50B7V1	FBQ60B7V1	
OUTDOOR UNITS			RKS35BVMB	RKS50BVMB9	RKS60BVMB9	RS50BVMB	RS60BVMB	
CAPACITY (3)	Cooling	min.-nom.-max.	kW	1.00~3.40~3.70	0.90~5.00~5.60	0.90~6.00~7.00	0.90~5.00~5.60	0.90~6.00~7.00
NOMINAL INPUT	Cooling		kW	1.21	1.92	2.19	1.92	2.19
EER				2.81	2.60	2.74	2.60	2.74
ENERGY LABEL	Cooling			C	E	D	E	D
ANNUAL ENERGY CONSUMPTION	Cooling		kWh	605	960	1,095	960	1,095

For combination indoor + outdoor units (air cooled):								
INDOOR UNITS			FBQ35B7V1	FBQ50B7V1	FBQ60B7V1			
OUTDOOR UNITS			RXS35BVMB	RXS50BVMB	RXS60BVMB			
CAPACITY (3)	Cooling	min.-nom.-max.	kW	1.00~3.40~3.70	0.90~5.00~5.60	0.90~6.00~7.00		
	Heating	min.-nom.-max.	kW	1.00~4.10~5.00	0.90~6.00~7.00	0.90~7.00~8.00		
NOMINAL INPUT	Cooling		kW	1.21	1.92	2.19		
	Heating		kW	1.28	1.87	2.50		
EER				2.81	2.60	2.74		
COP				3.20	3.21	2.80		
ENERGY LABEL	Cooling			C	E	D		
	Heating			D	C	E		
ANNUAL ENERGY CONSUMPTION	Cooling		kWh	605	960	1,095		

TECHNICAL SPECIFICATIONS								
For indoor units only:								
INDOOR UNITS			FBQ35B7V1	FBQ50B7V1	FBQ60B7V1			
DIMENSIONS	Unit	H	mm	300				
		W	mm	700		1000		
		D	mm	800				
WEIGHT	Unit		kg	30	31	41		
MATERIAL	Unit	Galvanised steel plate						
SOUND LEVEL	Sound pressure (cooling/heating) (1)	high	dB(A)	33/33		34/34		
		low	dB(A)	29/29		30/30		
	Sound power		dB(A)	52/52	53/53	60/60		
FAN	Air flow rate (cooling/heating)	high	m ³ /min	11.5/11.5	14/14	19/19		
		low	m ³ /min	9/9	10/10	14/14		
	Speed	steps		2 steps				
	Type			Sirocco fan				
	Qty x motor output	W		1 x 65	1 x 85	1 x 125		
	Drive			Direct drive				
	External static pressure (H-M-L)	Pa		88 - 49 - 20				
HEAT EXCHANGER	Type		Fin rhombus type, φ 7 Hi-XA tube					
	Rows x stages x fin pitch	mm	3 x 14 x 1.75					
	Face area	m ²	0.132		0.221			
AIR FILTER		Resin net (with mold resistant)						
PIPING CONNECTIONS	liquid	mm	φ6.35					
		mm	φ9.52		φ12.7			
	drain I.D.	mm	φ25					
	drain O.D.	mm	φ32					
INSULATION MATERIAL	Heat insulation	Both liquid and gas pipes						
	Sound absorbing insulation	Flame and heat resistant foamed polyethylene, regular foamed polyethylene and foamed PU						

For outdoor units only:	Pair application	See chapters RS-B + RKS-B + RXS-B
	Multi model application	See chapters 4MKS-B + 3MXS-B/4MXS-B



2 Specifications

2

NOMINAL CAPACITY and NOMINAL INPUT					
For indoor units only:					
INDOOR UNITS			FBQ71B7V3B	FBQ100B7V3B	FBQ125B7V3B
NOMINAL INPUT	Cooling	kW	-	-	-
	Heating	kW	-	-	-

For combination indoor + outdoor units (air cooled):					
INDOOR UNITS			FBQ71B7V3B	FBQ100B7V3B	FBQ125B7V3B
OUTDOOR UNITS			RZQ71B7V3B	RZQ100B7V3B	RZQ125B7V3B
CAPACITY (3)	Cooling	min.-nom.-max. kW			
	Heating	min.-nom.-max. kW			
NOMINAL INPUT	Cooling	min.-nom.-max. kW			
	Heating	min.-nom.-max. kW			
EER			3.55	3.49	3.14
COP			3.73	3.52	3.51
ENERGY LABEL	Cooling		A	A	B
	Heating		A	B	B
ANNUAL ENERGY CONSUMPTION	Cooling	kWh			

TECHNICAL SPECIFICATIONS						
For indoor units only:						
INDOOR UNITS			FBQ71B7V1	FBQ100B7V1	FBQ125B7V1	
DIMENSIONS	Unit	H	mm	300		
		W	mm	1000	1400	
		D	mm	800		
WEIGHT	Unit	kg	41	51	51	
MATERIAL	Unit		Galvanised steel plate			
SOUND LEVEL	Sound pressure (cooling/heating) (3)	high	dB(A)	34/34	36/36	38/38
		low	dB(A)	30/30	31/31	32/32
	Sound power (cooling/heating) (4)	dB(A)	60	62	63	
FAN	Air flow rate (cooling/heating)	high	m ³ /min	19/19	27/27	35/35
		low	m ³ /min	14/14	20/20	24/24
	Speed	steps		3 steps		
	Type			Sirocco fan		
	Qty x motor output	W	1 x 125	1 x 135	1 x 225	
	Drive			Direct drive		
HEAT EXCHANGER	Type		Fin rhombus type, ϕ 7 Hi-XA tube			
	Rows x stages x fin pitch	mm	3 x 14 x 1.75			
	Face area	m ²	0.221	0.338		
AIR FILTER			Resin net (with mold resistant)			
PIPING CONNECTIONS		liquid	mm	ϕ 9.52 (flare)		
		gas	mm	ϕ 15.9 (flare)		
		drain I.D.	mm	ϕ 25 (VP25)		
		drain O.D.	mm	ϕ 32 (VP25)		
INSULATION MATERIAL	Heat insulation		Both liquid and gas pipes			
For outdoor units only:	Pair application		See chapter RZQ-B			

3TW26021-1

4

2 Specifications



2

ELECTRICAL SPECIFICATIONS						
For indoor units only:				FBQ35B7V1	FBQ50B7V1	FBQ60B7V1
CURRENT	Nominal running current	cooling/heating	A	0.5	0.7	0.9
	Maximum running current	cooling/heating	A	See chapters RS-B + RKS-B + RXS-B		

For combination indoor units + outdoor units:				FBQ35B7V1	FBQ50B7V1	FBQ60B7V1	FBQ50B7V1	FBQ60B7V1
				RKS35BVMB	RKS50BVMB9	RKS60BVMB9	RS50BVMB	RS60BVMB
CURRENT	Nominal running current	cooling	A	See chapter RKS-B			See chapter RS-B	
	Maximum running current	cooling	A	See chapter RKS-B			See chapter RS-B	
	Starting current	cooling	A	See chapter RKS-B			See chapter RS-B	

For combination indoor units + outdoor units:				FBQ35B7V1	FBQ50B7V1	FBQ60B7V1
				RXS35BVMB	RXS50BVMB	RXS60BVMB
CURRENT	Nominal running current	cooling/heating	A	See chapter RXS-B		
	Maximum running current	cooling/heating	A	See chapter RXS-B		
	Starting current	cooling/heating	A	See chapter RXS-B		

For indoor units only:				FBQ35B7V1	FBQ50B7V1	FBQ60B7V1
POWER SUPPLY				V1	V1	V1
NOMINAL DISTRIBUTION SYSTEM VOLTAGE	Phase			1~	1~	1~
	Frequency		Hz	50	50	50
	Voltage		V	230	230	230

3TW25111-1
3TW25121-1
3TW25131-1

ELECTRICAL SPECIFICATIONS						
For indoor units only:				FBQ71B7V3B	FBQ100B7V3B	FBQ125B7V3B
CURRENT	Nominal running current	cooling/heating	A	See chapter RZQ-B		
	Maximum running current	cooling/heating	A	See chapter RZQ-B		

For combination indoor units + outdoor units:				FBQ71B7V3B	FBQ100B7V3B	FBQ125B7V3B
				RZQ71B7V3B	RZQ100B7V3B	RZQ125B7V3B
CURRENT	Nominal running current	cooling	A	See chapter RZQ-B		
	Maximum running current	cooling	A	See chapter RZQ-B		
	Starting current	cooling	A	See chapter RZQ-B		

For indoor units only:				FBQ71B7V3B	FBQ100B7V3B	FBQ125B7V3B
POWER SUPPLY				V3	V3	V3
NOMINAL DISTRIBUTION SYSTEM VOLTAGE	Phase			1~	1~	1~
	Frequency		Hz	50	50	50
	Voltage		V	230	230	230

3TW26021-1

NOTES

- Nominal cooling capacities are based on: indoor temperature 27°CDB/19°CWB * outdoor temperature 35°CDB * refrigerant piping length: 7.5m * level difference: 0m.
- Nominal heating capacities are based on: indoor temperature: 20°CDB * outdoor temperature: 7°CDB/6°CWB * refrigerant piping length: 7.5m * level difference 0m.
- Capacities are net, including a deduction for cooling (an addition for heating) for indoor fan motor heat.
- The sound pressure level is measured at 1.5m distance from the unit. It is a relative value, depending on the distance and acoustic environment. For measuring conditions: please refer to item 6 of this chapter.
- The sound power level is an absolute value indicating the "power" which a sound source generates.
- Energy label: scale from A (most efficient) to G (less efficient)..
- Annual energy consumption: based on average use of 500 running hours per year at full load (= nominal conditions)



3 Dimensional drawings

3

FBQ35-50B7

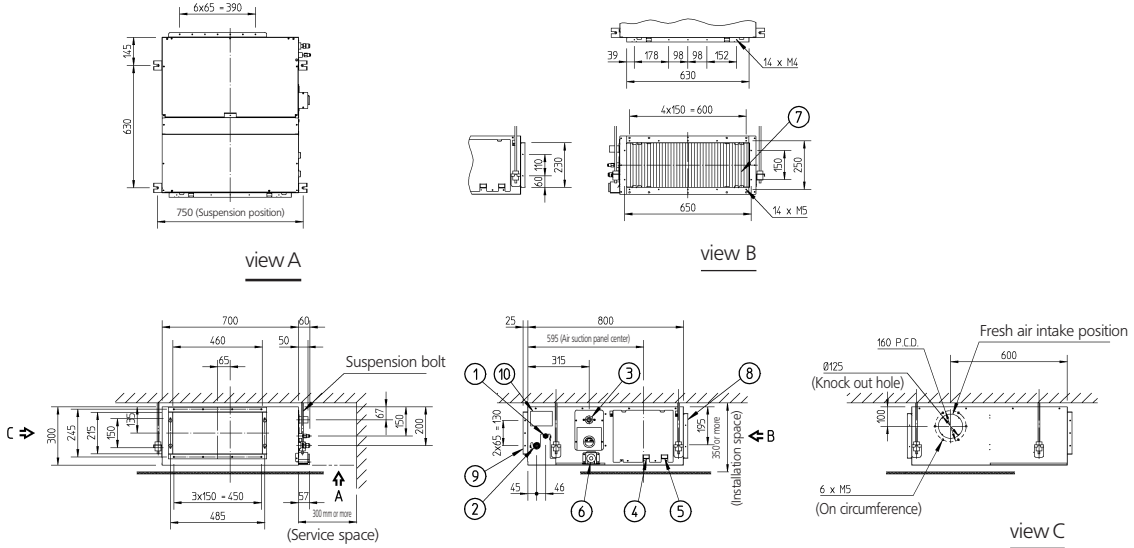

Notes:
 1. Refer to 'outlook drawing for installing optional accessories' when installing optional accessories.
 2. The required ceiling depth varies according to configuration of the specific system.
 3. For maintenance of the air filter, it is necessary to provide a service access panel according to the installation method. (Refer to the 'filter installation method' drawing)

- 1 Liquid pipe connection ϕ A Flare connection
- 2 Gas pipe connection ϕ B Flare connection
- 3 Drain pipe connection VP25 (I.D. ϕ 32, I.D. ϕ 25)
- 4 Remote control wiring connection
- 5 Power supply connection
- 6 Drain hole (I.D. ϕ 32, I.D. ϕ 25)
- 7 Air filter
- 8 Air suction side
- 9 Air discharge side
- 10 Name plate

Model	A	B
FBQ35	6.35	9.52
FBQ50	6.35	12.70

3TW22224-1C

FBQ35-50B7 With canvas

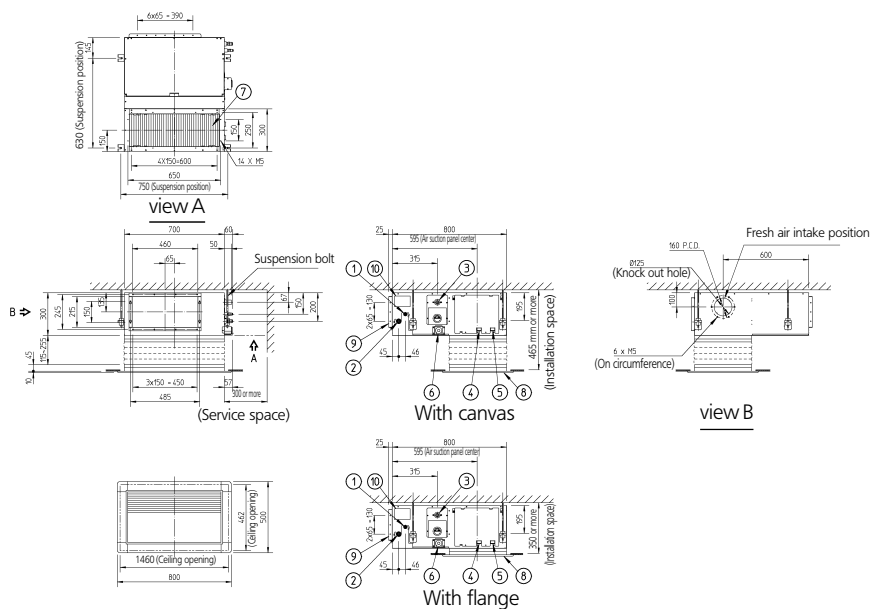

Notes:
 1. Refer to 'outlook drawing for installing optional accessories' when installing optional accessories.
 2. Optional decoration panel: BYBS45DJW1 (Light ivory white 10Y9/0.5)
 3. The required ceiling depth varies according to configuration of the specific system

- 1 Liquid pipe connection ϕ A Flare connection
- 2 Gas pipe connection ϕ B Flare connection
- 3 Drain pipe connection VP25 (I.D. ϕ 32, I.D. ϕ 25)
- 4 Remote control wiring connection
- 5 Power supply connection
- 6 Drain hole VP25 (I.D. ϕ 32, I.D. ϕ 25)
- 7 Air filter
- 8 Air suction side
- 9 Air discharge side
- 10 Name plate

Model	A	B
FBQ35	6.35	9.52
FBQ50	6.35	12.70

3TW22224-2C

6

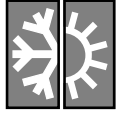

3 Dimensional drawings

3

FBQ60-71B7

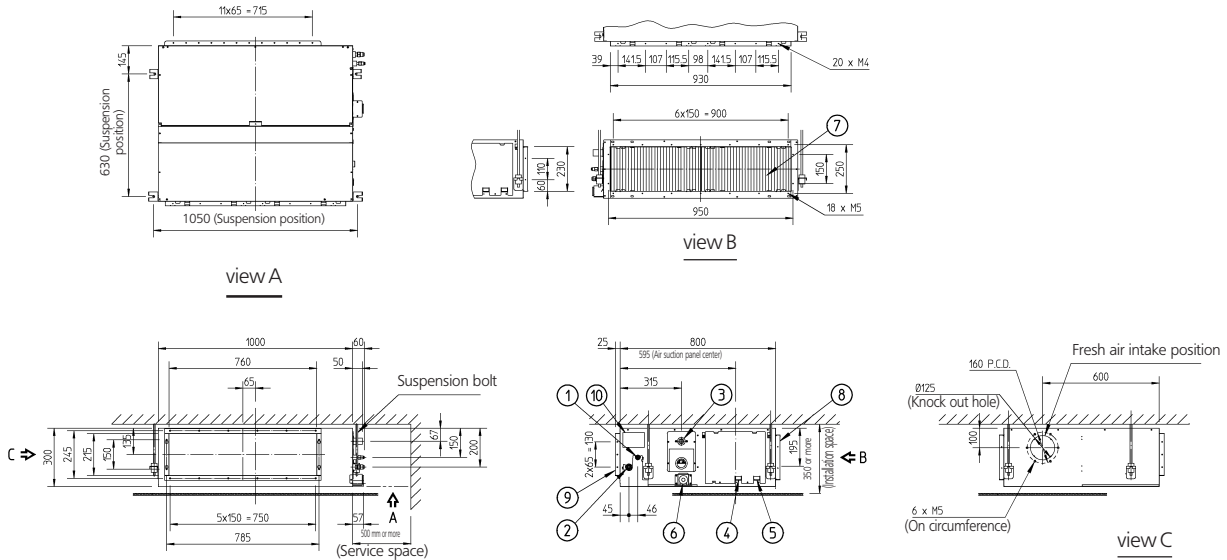

Notes:
 1. Refer to 'outlook drawing for installing optional accessories' when installing optional accessories.
 2. The required ceiling depth varies according to configuration of the specific system.
 3. For maintenance of the air filter, it is necessary to provide a service access panel according to the installation method. (Refer to the 'filter installation method' drawing)

- 1 Liquid pipe connection ϕ A Flare connection
- 2 Gas pipe connection ϕ B Flare connection
- 3 Drain pipe connection VP25 (I.D. ϕ 32, I.D. ϕ 25)
- 4 Remote control wiring connection
- 5 Power supply connection
- 6 Drain hole (I.D. ϕ 32, I.D. ϕ 25)
- 7 Air filter
- 8 Air suction side
- 9 Air discharge side
- 10 Name plate

Model	A	B
FBQ60	6.35	12.70
FBQ71	9.52	15.90

3TW22244-1D

FBQ60-71B7 With canvas

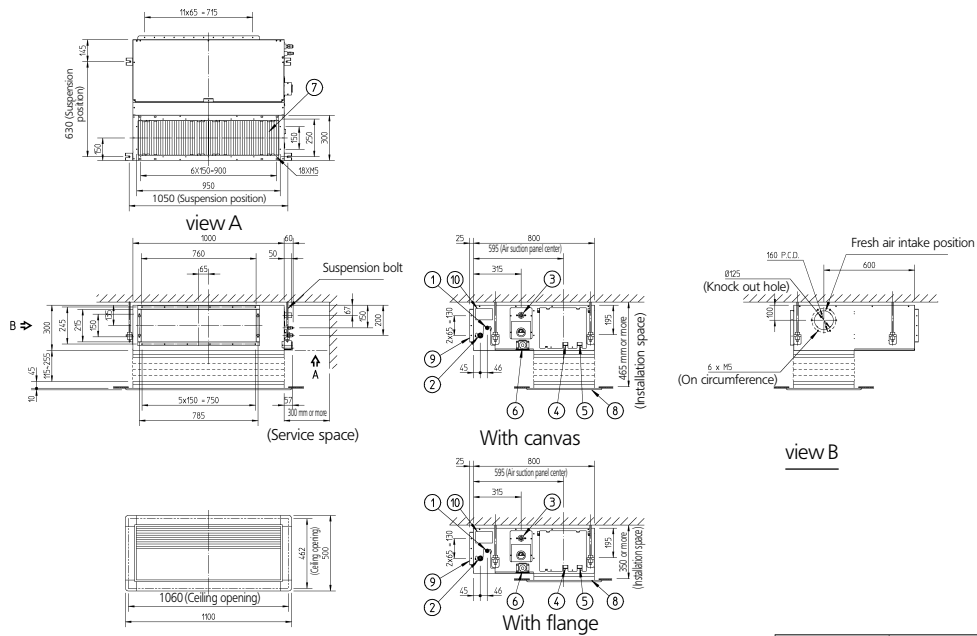

Notes:
 1. Refer to 'outlook drawing for installing optional accessories' when installing optional accessories.
 2. Optional decoration panel: BYBS125D/W1 (Light ivory white 10Y9/0.5)
 3. The required ceiling depth varies according to configuration of the specific system

- 1 Liquid pipe connection ϕ A Flare connection
- 2 Gas pipe connection ϕ B Flare connection
- 3 Drain pipe connection VP25 (I.D. ϕ 32, I.D. ϕ 25)
- 4 Remote control wiring connection
- 5 Power supply connection
- 6 Drain hole VP25 (I.D. ϕ 32, I.D. ϕ 25)
- 7 Air filter
- 8 Air suction side
- 9 Air discharge side
- 10 Name plate

Model	A	B
FBQ60	6.35	12.70
FBQ71	9.52	15.90

3TW22244-2D

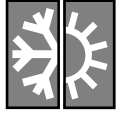

3 Dimensional drawings

3

FBQ100-125B7

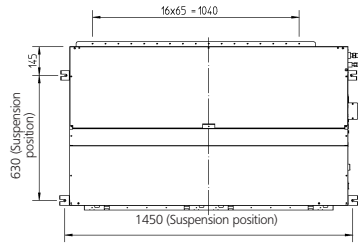

view A

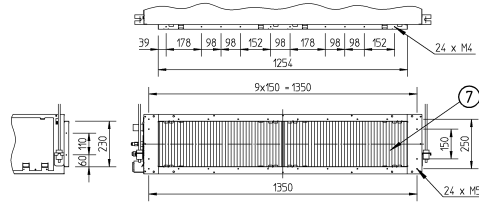

view B

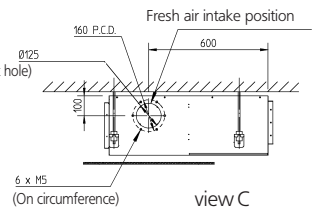
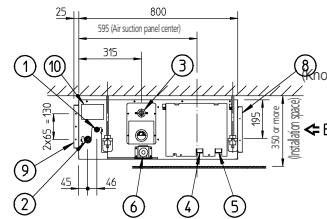
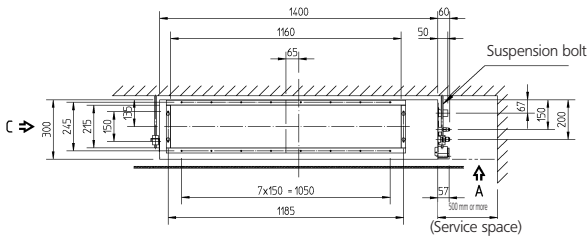

view C

Notes:

1. Refer to 'outlook drawing for installing optional accessories' when installing optional accessories.
2. The required ceiling depth varies according to configuration of the specific system.
3. For maintenance of the air filter, it is necessary to provide a service access panel according to the installation method. (Refer to the 'filter installation method' drawing)

- 1 Liquid pipe connection ϕ A Flare connection
- 2 Gas pipe connection ϕ B Flare connection
- 3 Drain pipe connection VP25 (I.D. ϕ 32, I.D. ϕ 25)
- 4 Remote control wiring connection
- 5 Power supply connection
- 6 Drain hole (I.D. ϕ 32, I.D. ϕ 25)
- 7 Air filter
- 8 Air suction side
- 9 Air discharge side
- 10 Name plate

Model	A	B
FBQ100	9.52	15.90
FBQ125	9.52	15.90

3TW22254-1C

FBQ100-125B7

With canvas

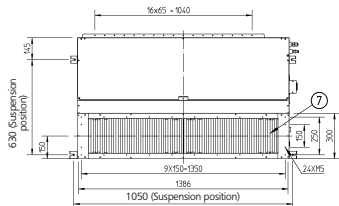

view A

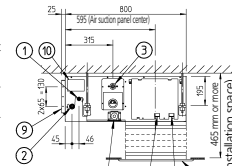

With canvas

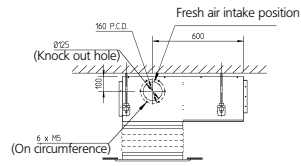

view B

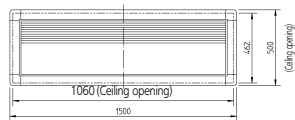
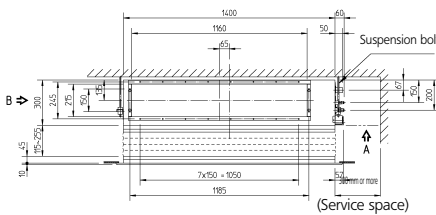

With flange

Notes:

1. Refer to 'outlook drawing for installing optional accessories' when installing optional accessories.
2. Optional decoration panel: BYBS125D/W1 (Light ivory white 10Y9/0.5)
3. The required ceiling depth varies according to configuration of the specific system

- 1 Liquid pipe connection ϕ A Flare connection
- 2 Gas pipe connection ϕ B Flare connection
- 3 Drain pipe connection VP25 (I.D. ϕ 32, I.D. ϕ 25)
- 4 Remote control wiring connection
- 5 Power supply connection
- 6 Drain hole VP25 (I.D. ϕ 32, I.D. ϕ 25)
- 7 Air filter
- 8 Air suction side
- 9 Air discharge side
- 10 Name plate

Model	A	B
FBQ100	9.52	15.90
FBQ125	9.52	15.90

3TW22254-2C



4 Piping diagrams

4

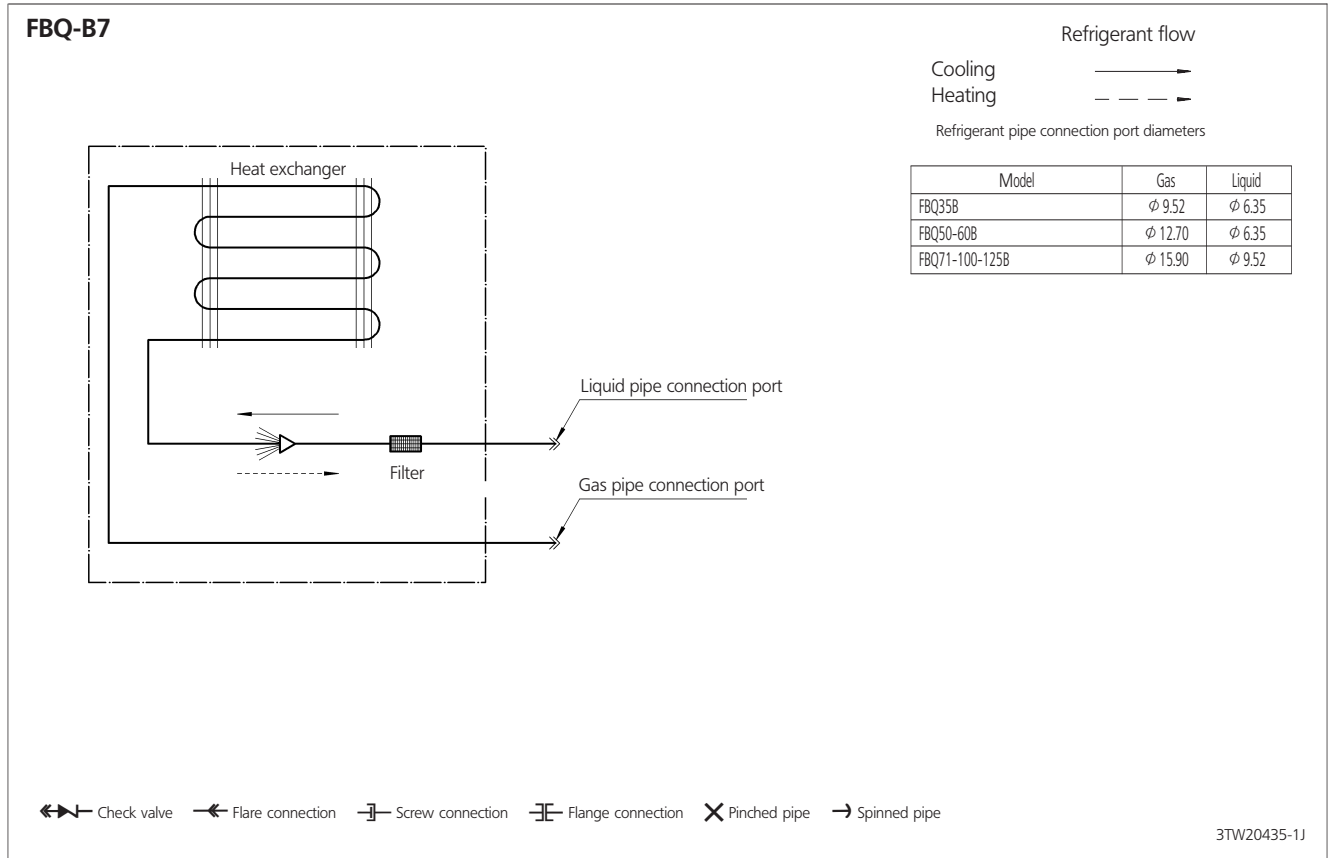



5 Wiring diagrams

5

FBQ35-60B7

Notes

- When using the central remote control, see manual for connection to the unit.
- The infrared remote control model varies according to the combination system. refer to technical materials and catalogues, etc. before connecting.

- Field wiring
- Terminal
- Connector
- Wire clamp
- Protective earth (screw)

Colours
BLK: Black / WHT: White / RED: Red / BLU: Blue / GRY: Grey / ORG: Orange

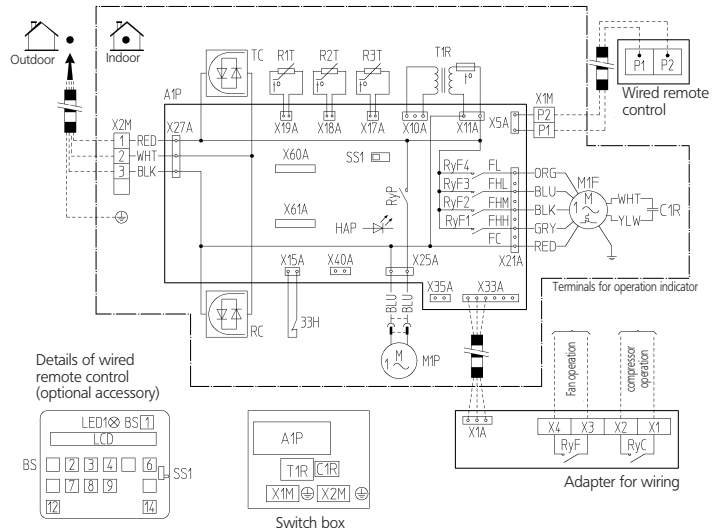

Details of wired remote control (optional accessory)

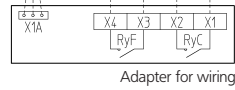
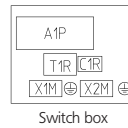
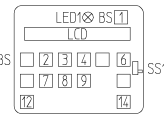

33H	Floot switch	R1T	Thermistor (air)	Wired remote control	BS14	Filter sign reset button	Adapter for wiring
A1P	Printed circuit board	R2T	Thermistor (liquid)	B51	On/Off button	H1P	Light emitting diode (service monitor red)
T1R	Power supply transformer (transformer 220-240V/218V)	R3T	Thermistor (coil)	B52	Timer mode start/stop button	LCD	Liquid crystal display (LCD)
C1R	Capacitor (fan)	RvF1-4	Magnetic relay (fan)	B53,B58	Programming time button	SS1	Selector switch (main/sub)
F1T	Thermal fuse (152°C) (M1F embedded)	RvP	Magnetic relay (drain pump)	B54,B59	Temperature setting button		
H1P, H2P	Light emitting diode (service monitor green)	SS1	Selector switch (emergency)	B56	Operation mode selector button	X33A	Connector (adapter for wiring)
M1F	Motor (fan)	X1M	Terminal strip	B57	Timer on/off button	X35A	Connector (group control adapter)
M1P	Motor (drain pump)	X2M	Terminal strip	B511	Fan speed control button	X40A	Connector (remote ON/OFF forced Off)
		RC	Signal receiver circuit	B512	Inspection/test button		
		TC	Signal transmission circuit				

2TW25116-1A

FBQ71B7

Notes

- When using the central remote control, see manual for connection to the unit.
- The infrared remote control model varies according to the combination system. refer to technical materials and catalogues, etc. before connecting.

- Field wiring
- Terminal
- Connector
- Wire clamp
- Protective earth (screw)

Colours
BLK: Black / WHT: White / RED: Red / BLU: Blue / GRY: Grey / ORG: Orange

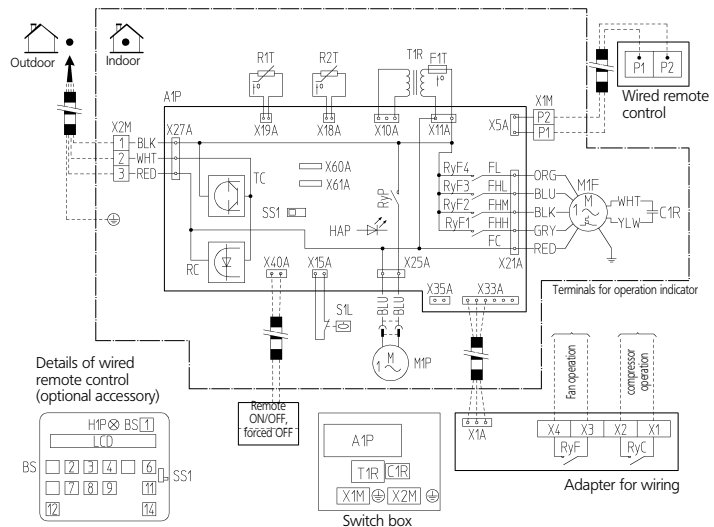

Details of wired remote control (optional accessory)

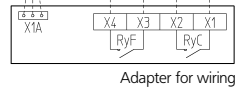
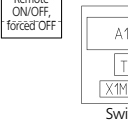
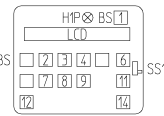

S1L	Floot switch	R1T	Thermistor (air)	Wired remote control	BS14	Filter sign reset button	Adapter for wiring
A1P	Printed circuit board	R2T	Thermistor (coil)	B51	On/Off button	H1P	Light emitting diode (service monitor red)
T1R	Power supply transformer (transformer 220-240V/218V)	RvF1-4	Magnetic relay (fan)	B52	Timer mode start/stop button	LCD	Liquid crystal display (LCD)
C1R	Capacitor (fan)	RvP	Magnetic relay (drain pump)	B53,B58	Programming time button	SS1	Selector switch (main/sub)
F1T	Thermal fuse (152°C) (M1F embedded)	SS1	Selector switch (emergency)	B54,B59	Temperature setting button		
H1P	Light emitting diode (service monitor green)	X1M	Terminal strip	B56	Operation mode selector button	X33A	Connector (adapter for wiring)
M1F	Motor (fan)	X2M	Terminal strip	B57	Timer on/off button	X35A	Connector (group control adapter)
M1P	Motor (drain pump)	RC	Signal receiver circuit	B511	Fan speed control button	X40A	Connector (remote ON/OFF forced Off)
		TC	Signal transmission circuit	B512	Inspection/test button		

2TW26026-1

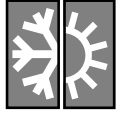

5 Wiring diagrams

5

FBQ100-125B7

Notes

1. When using the central remote control, see manual for connection to the unit.
2. The infrared remote control model varies according to the combination system. refer to technical materials and catalogues, etc. before connecting.

- Field wiring
- Terminal
- → Connector
- Wire clamp
- ⊕ Protective earth (screw)

Colours
 BLK: Black / WHT: White / RED: Red / BLU: Blue / GRY: Grey / ORG: Orange

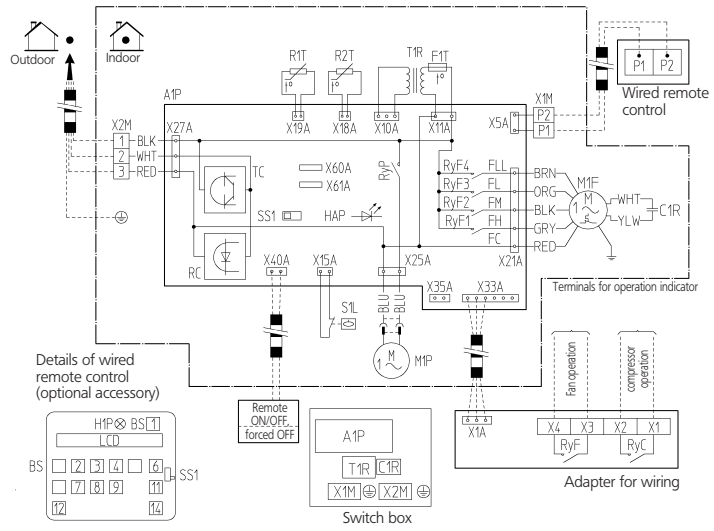

S1L	Float switch	R1T	Thermistor (air)	Wired remote control	BS14	Filter sign reset button	Adapter for wiring
A1P	Printed circuit board	R2T	Thermistor (coil)	B51	On/Off button	H1P	RvC/RvF
T1R	Power supply transformer (transformer 220-240V/218V)	RvF1-4	Magnetic relay (fan)	B52	Timer mode start/stop button	LCD	Magnetic relay
C1R	Capacitor (fan)	RvP	Magnetic relay (drain pump)	B53,B58	Programming time button	SS1	Connector for optional parts
F1T	Thermal fuse (152°C (M1F embedded))	SS1	Selector switch (emergency)	B54,B59	Temperature setting button		X60A, X61A
HAP	Light emitting diode (service monitor green)	X1M	Terminal strip	B56	Operation mode selector button		Connector (interface adapter for sky air series)
M1F	Motor (fan)	X2M	Terminal strip	B57	Timer on/off button	X33A	Connector (adapter for wiring)
M1P	Motor (drain pump)	RC	Signal receiver circuit	B58	Fan speed control button	X35A	Connector (group control adapter)
		TC	Signal transmission circuit	B511	Inspection/test button	X40A	Connector (remote ON/OFF forced Off)

2TW26056-1



6 Sound level

6-1 Sound level data

6
6-1

Model	230V, 50Hz		Measuring location	Sound power level (H) (cooling/heating)
	Cooling/Heating			
	H	L		
FBQ35B7V1	33/33	29/29		52/52
FBQ50B7V1	33/33	29/29		53/53
FBQ60B7V1	34/34	30/30		60/60
FBQ71B7V1	34/34	30/30		60/-
FBQ100B7V1	36/36	31/31		62/-
FBQ125B7V1	38/38	32/32		63/-

6-2 Sound pressure spectrum

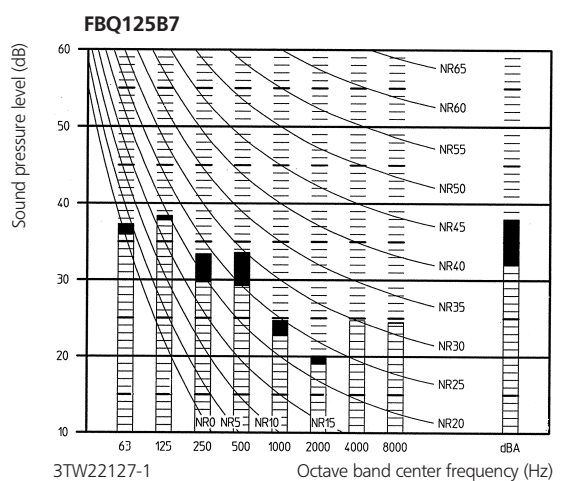
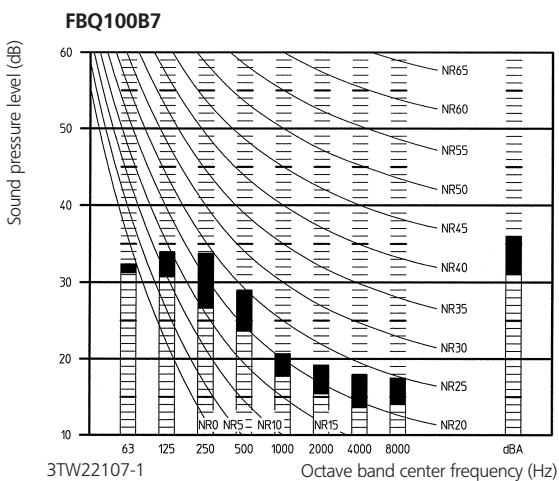
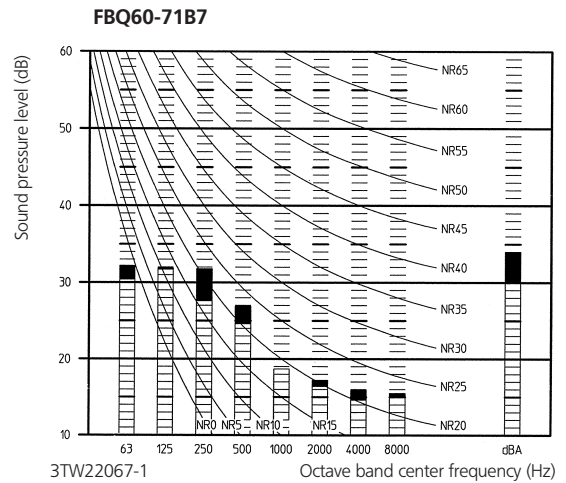
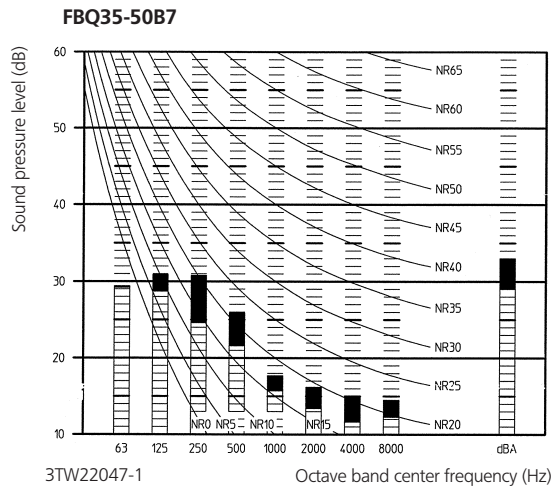

NOTES

- 1 Data is valid at free field condition
- 2 Operation sound levels are valid at nominal operation condition 230V
- 3 dB(A) = A-weighted sound pressure level (A-scale according to IEC)
- 4 Reference acoustic pressure 0dB = 20μPa

Legend

- High speed
- Low speed



7 Fan characteristics

Cooling only

7

FBQ35B7

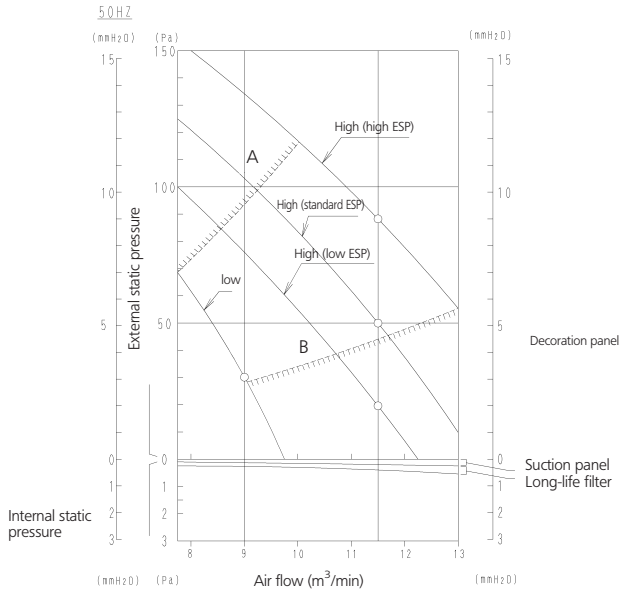

DU220-411C

FBQ50B7

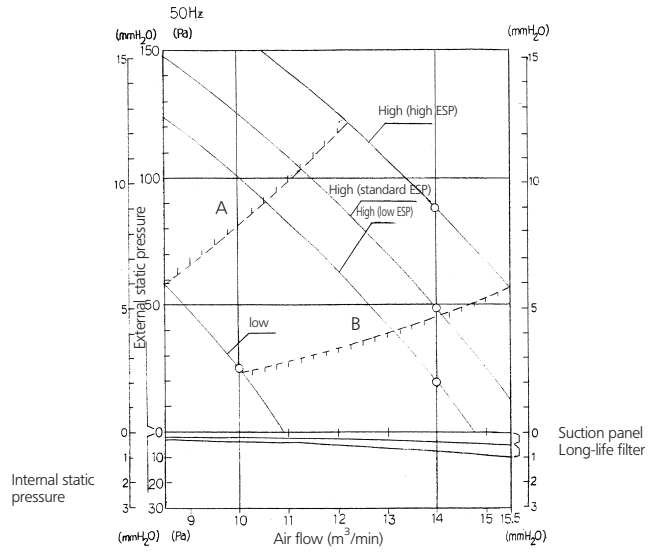

DU220-412A

FBQ60B7

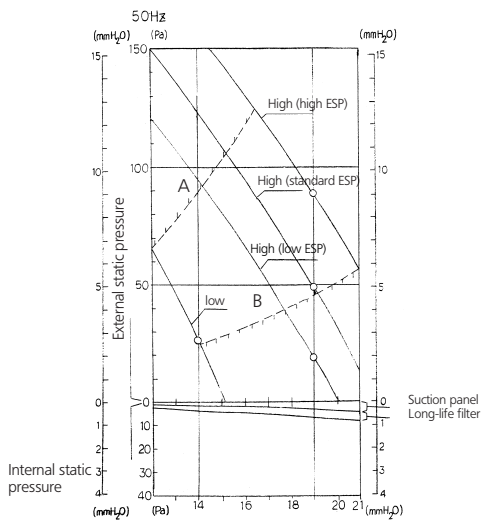

DU220-413A

NOTES

1. The wired remote control can be used to switch between 'high' and 'low'
2. The air flow is set to 'standard' before leaving the factory. It is possible to switch between 'standard EPS' an 'high 'EPS' by programming on the remote control.
3. The internal static pressure indicates the characteristics of the fan when a suction panel (optional accessory) and a canvas for the suction panel (optional accessory) are incorporated into the main unit (with a long-life filter).

A = Upper limit of external static pressure (high ESP)
 B = Lower limit of external static pressure (high ESP)











8 Accessories

8-1 Standard accessories

8

Check if the following accessories are included with your unit.

8-1

 <p>Clamp 1 pc.</p>	<p>Also used as packing material</p>  <p>Paper pattern for installation 1 pc.</p>	 <p>Drain hose 1 pc.</p>
<p>Insulation for fitting 1 of each</p>  <p>For gas pipe</p>  <p>For liquid pipe</p>		 <p>Washer for hanging bracket 8 pcs.</p>
<p>FBQ35-50: 8pcs. FBQ60: 12pcs.</p>  <p>Screws for duct flanges 1 set</p>		 <p>Infrared 6 pcs.</p>

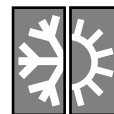

8 Accessories

8-2 Optional accessories

FBQ-B7

8

8-2

Nr	Item	FBQ35,50	FBQ60,71	FBQ100,125
1	Panel related	Decoration panel	BYBS45DJW1	BYBS125DJW1
		Service access panel	KTBJ25K56W	KTBJ25K80W
2	Filter related	High-efficiency filter 65% (colorimetric method) *1	KAFJ252L56	KAFJ252L80
		High-efficiency filter 90% (colorimetric method) *1	KAFJ253L56	KAFJ253L80
		Filter chamber for bottom suction	KAJ25L56D	KAJ25L80D
		Filter chamber for rear suction	KAJ25L56B	KAJ25L80B
3	Air inlet and air discharge outlet related	Air suction canvas	KSA-25K56	KSA-25K80
		Blind board/screening door	KBBJ25K56	KBBJ25K80
		Air discharge adapter for round duct	KDAJ25K56	KDAJ25K71

Nr	Item	Type	FBQ35,50	FBQ60,71	FBQ100,125
1	Remote control	Wired type		BRC1D527	
2	Central remote control			DCS302B51	
3	Unified ON/OFF control			DCS301B51	
4	Schedule timer			DST301B51	
5	Adapter for wiring (interlock for fresh air intake fan)			KRP1B54	
6	Wiring adaptor for electrical appendices			KRP4A51	
7	Interface adapter for Sky Air series			DTA112B51	
8	Remote ON/OFF, forced OFF			EKRORO	
9	Option PCB for external electrical heater, humidifier and/or hour meter *2			EKRP1B2	

3TW25119-1C

*1 If installing a high efficiency filter on the unit, an assembly chamber for either bottom or rear suction is required.

*2 Electrical heater, humidifier and hour meter are field supply. These parts should not be installed inside the equipment. (Refer to installation manual EKRP1B2).



9 Control systems

9-1 Wired remote control

9

9-1

BRC1D527

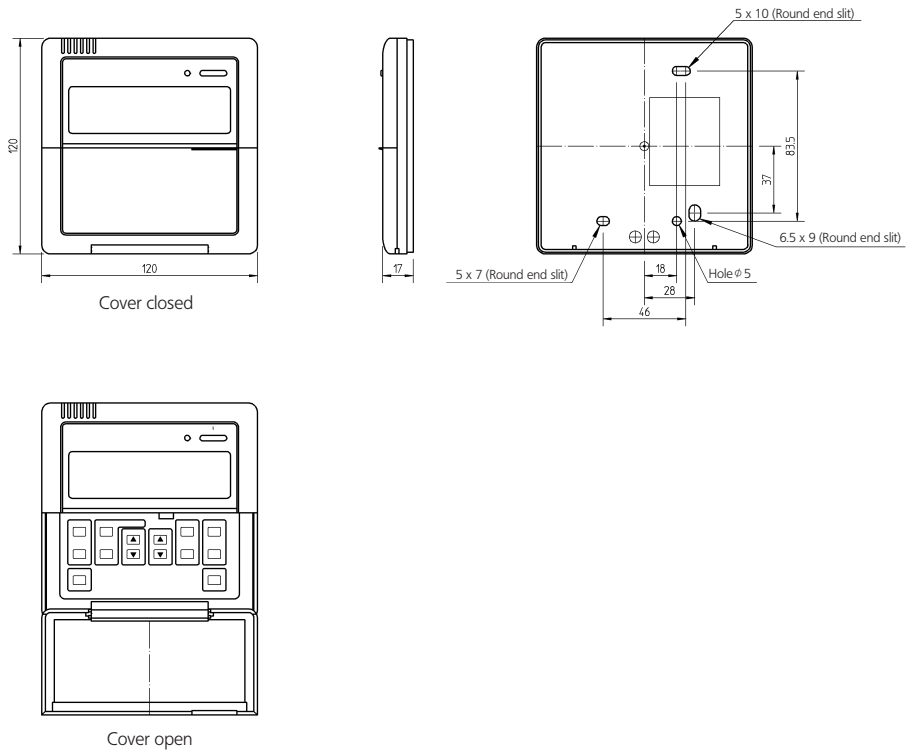

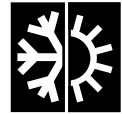

10 Center of gravity

10

FBQ-B7

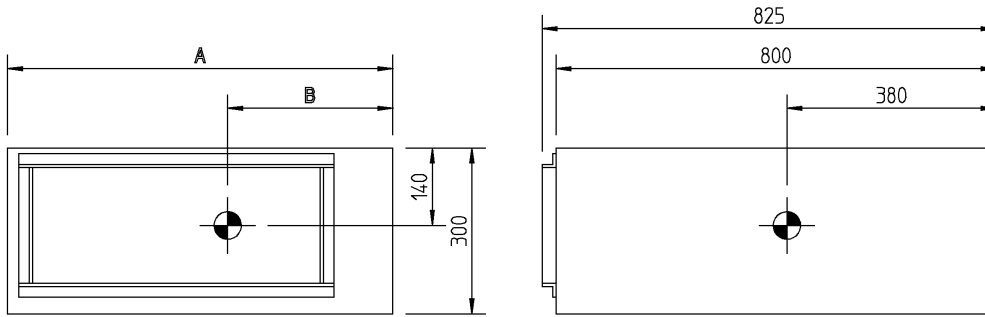

Model	A	B
FBQ35,50	700	300
FBQ60	1,000	460
FBQ71	1,000	460
FBQ100,125	1,400	640

4TW20169-2F

11 Safety device settings

Model	Safety devices	35	45-50	60	71	100	125
FBQ~B	Fuse	5A/250V	5A/250V	5A/250V	—	—	—
	Fan motor thermal fuse (°C)	152±2	152±2	152±2	152±2	152±2	152±2
	Fan motor thermal protector (°C)	—	—	—	—	—	—

3TW21009-2E



12 Installation

12

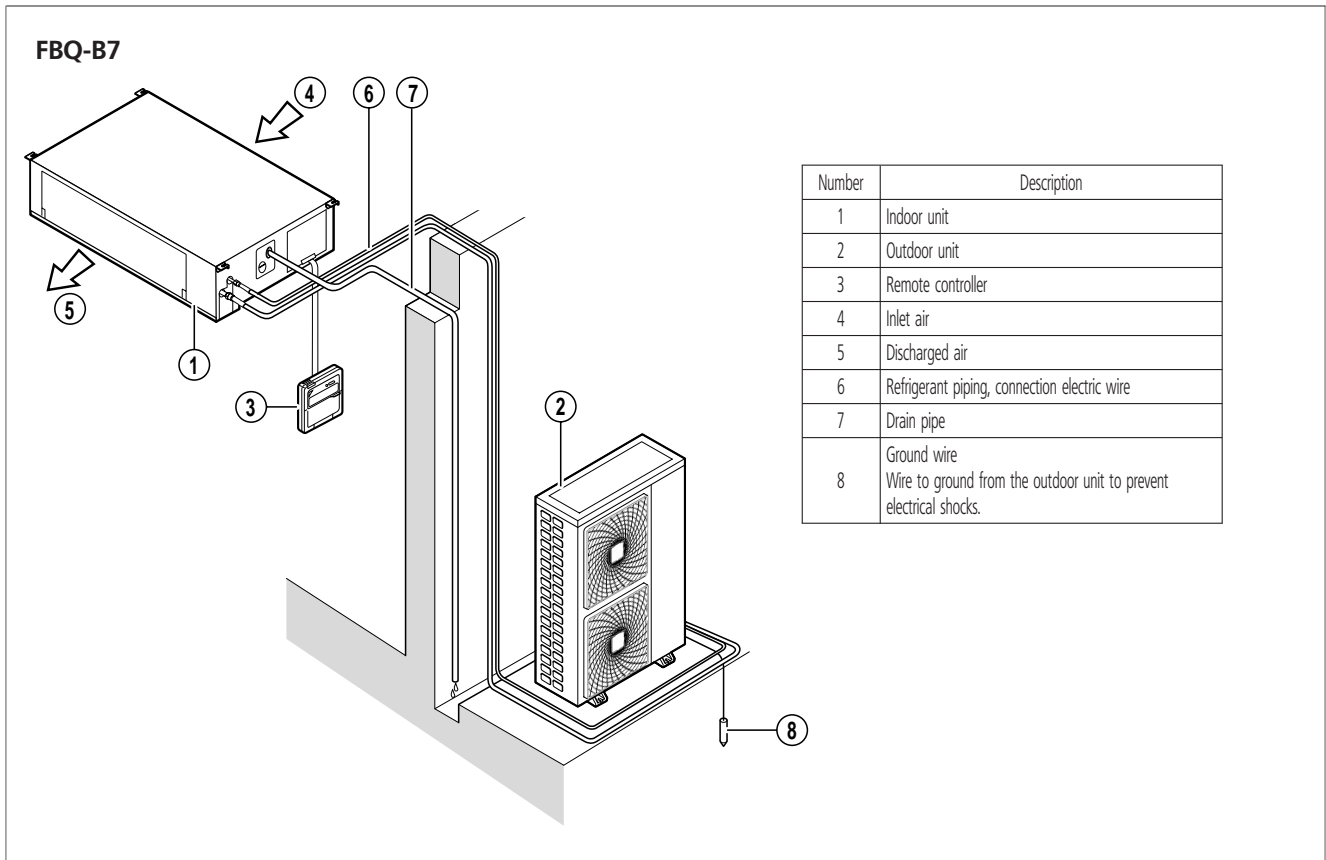

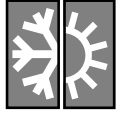

12 Installation

12-1 Filter installation method

12
12-1

FBQ-B7

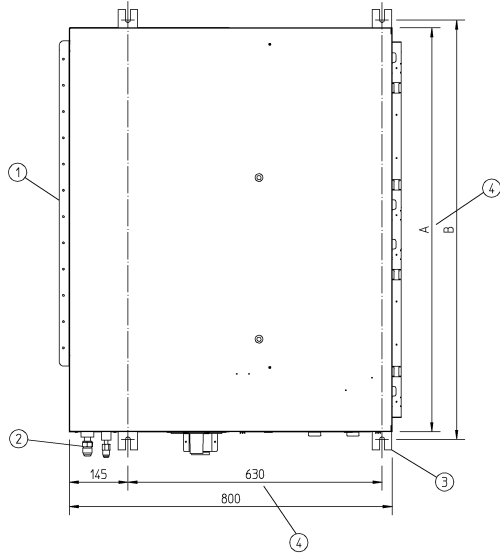

Suspension bolt pitch

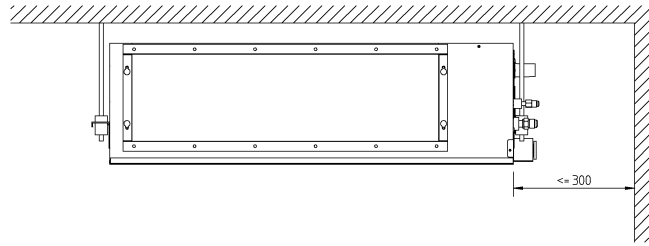

Service space

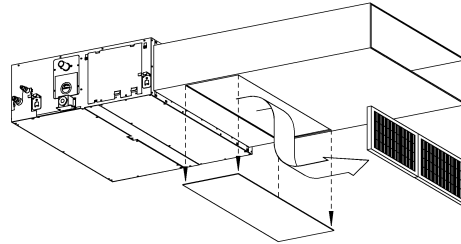

Number	Description
1	Indoor unit
2	Pipe connections
3	Suspension bolt pitch (4x)
4	Suspension bolt pitch distance

Unit	A	B
FBQ35,50	700	750
FBQ60	1000	1050

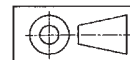

3TW22043-6A



12 Installation

12-1 Filter installation method

12
12-1

FBQ-B7

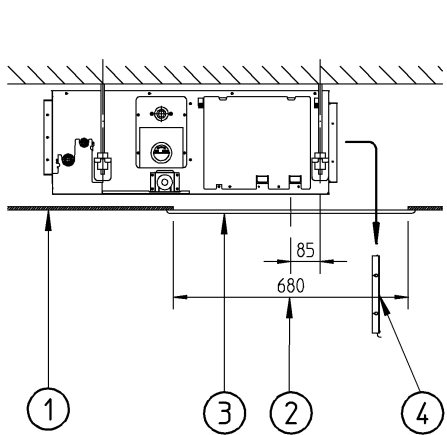

Installation without duct

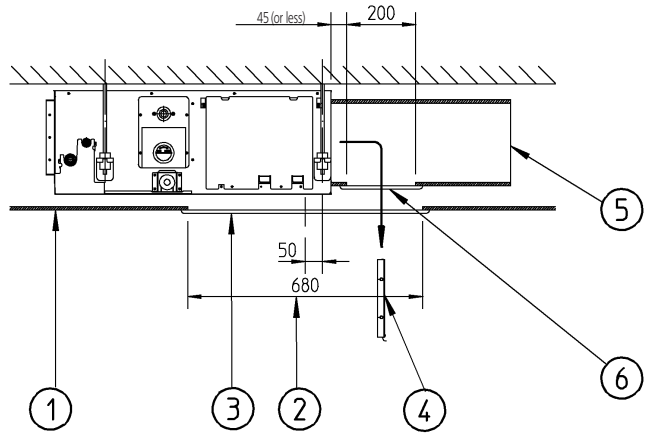

Installation with duct

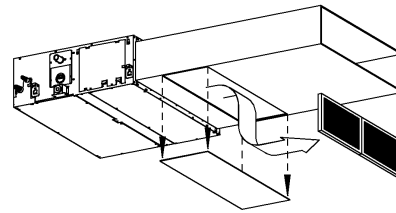

Number	Description
1	False ceiling
2	Ceiling opening
3	Service access panel (optional)
4	Air filter
5	Air inlet duct
6	Duct service opening

NOTES

- When installing the unit with rear suction, a service opening is necessary for the maintenance of the air filters.
- When installing the unit with a suction duct, a service opening must be provided in the duct.
- An optional service access panel is available:

Model	Service access panel
FBQ35,50	KTBJ25K56W
FBQ60,71	KTBJ25K80W
FBQ100,125	KTBJ25K160W

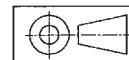

3TW22044-3B



12 Installation

12-2 Switch box connections

12
12-2

FBQ-B7

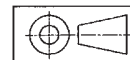
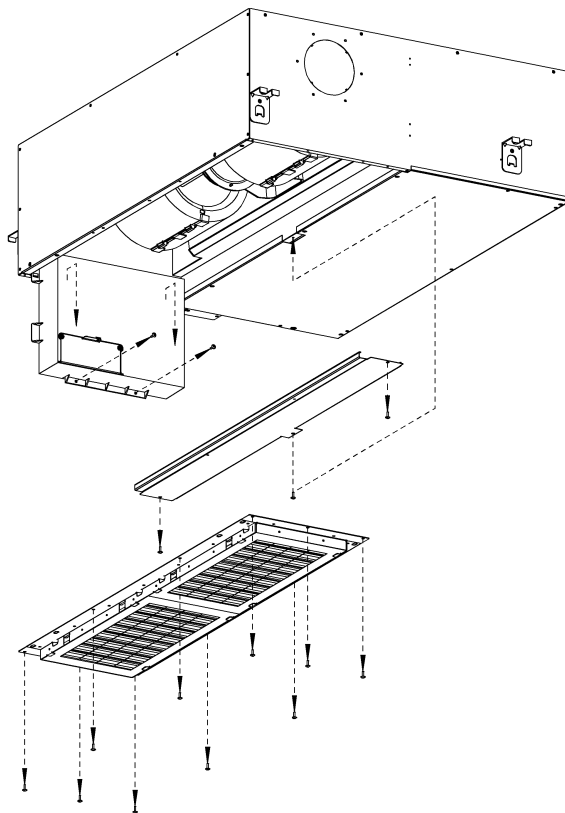
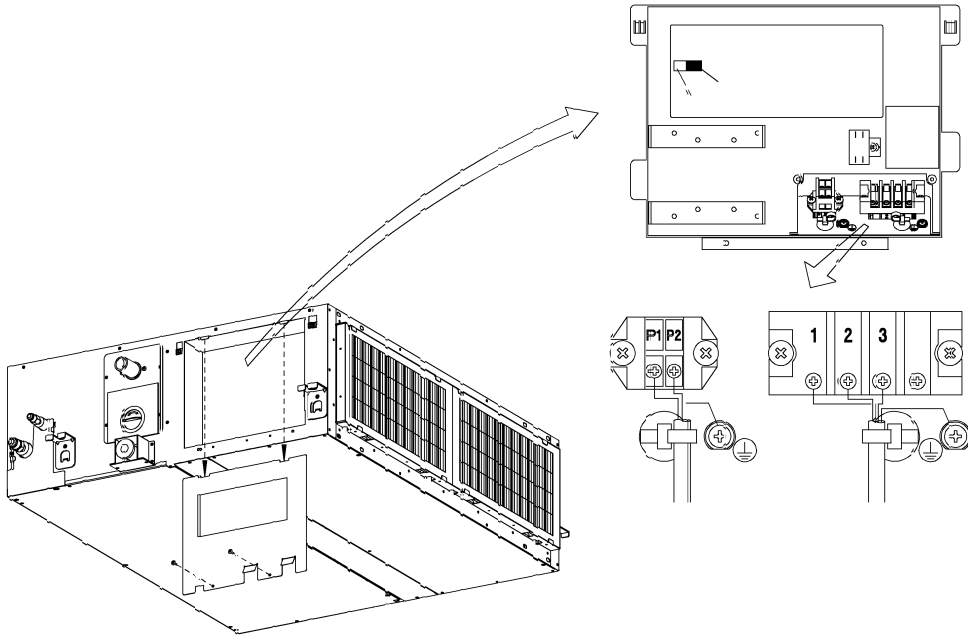

3TW22043-5A