



# technical data

**FCQ-B7**

**4-way Blow Ceiling  
Mounted Casette**



air conditioning systems

# Split Sky Air

# Split - Sky Air



ISO14001 assures an effective environmental management system in order to help protect human health and the environment from the potential impact of our activities, products and services and to assist in maintaining and improving the quality of the environment



Daikin units comply with the European regulations that guarantee the safety of the product.



Daikin Europe N.V. is approved by LRQA for its Quality Management System in accordance with the ISO9001 standard. ISO9001 pertains to quality assurance regarding design, development, manufacturing as well as to services related to the product.



Daikin Europe N.V. is participating in the EUROVENT Certification Programme. Products are as listed in the EUROVENT Directory of Certified Products.

Specifications are subject to change without prior notice.

## **DAIKIN EUROPE N.V.**

Zandvoordestraat 300  
B - 8400 Ostend Belgium  
Internet: <http://www.daikineurope.com>



# TABLE OF CONTENTS

## FCQ-B7



1	Features .....	2
2	Specifications .....	3
	Nominal capacity, capacity steps and nominal input	
	Technical specifications	
	Electrical specifications	
3	Dimensional drawings .....	6
4	Piping diagrams .....	7
5	Wiring diagrams .....	8
6	Sound level .....	9
	Sound level data	
	Sound pressure spectrum	
7	Air flow patterns .....	10
8	Branch duct connections .....	14
9	Accessories .....	20
	Optional accessories	
10	Control systems .....	23
11	Center of gravity .....	24
12	Safety device settings .....	24
13	Installation .....	25

\* For capacity tables, please refer to part II: outdoor units





# 1 Features

1

- Leaves maximum floor and wall space for furniture, decoration and fittings
  - Fits flush into each ceiling
  - Extremely quiet in operation both indoors and outdoors
  - Air can be discharged in any of four directions
  - Possibility of using 1 or 2 branches for better air distribution
  - Possibility to shut off 1 or 2 flaps for easy installation in corners
  - Air flow distribution for ceiling heights up to 4.2m without loss of capacity
  - Up to 4 indoor units can be connected to 1 Multi outdoor unit. All indoor units are individually controllable with remote control and do not need to be installed in the same room.
- The wired remote control has following features:
    - A real time clock
    - A schedule timer:
      - Possibility to program a weekly schedule timer.
      - Possibility to program 5 actions for each day of the week.
    - Limit operation (min./max.): room temperature is controlled within adjustable upper and lower limits. This can be activated manually or by schedule timer.
    - Home leave (frost protection): during absence, the indoor temperature can be maintained at a certain level. This function can also switch the unit ON/OFF.



Optional



Optional



Optional



2 steps



35-60



35-60



## 2 Specifications



NOMINAL CAPACITY and NOMINAL INPUT					
For indoor units only:					
INDOOR UNITS			FCQ35B7V1	FCQ50B7V1	FCQ60B7V1
NOMINAL INPUT	Cooling	kW	0.140	0.140	0.161
	Heating	kW	0.140	0.140	0.161

For combination indoor + outdoor units (air cooled):								
INDOOR UNITS				FCQ35B7V1	FCQ50B7V1	FCQ60B7V1	FCQ50B7V1	FCQ60B7V1
OUTDOOR UNITS				RKS35BVMB	RKS50BVMB9	RKS60BVMB9	RS50BVMB	RS60BVMB
CAPACITY (3)	Cooling	min.-nom.-max.	kW	1.00~3.40~3.70	0.90~5.00~5.60	0.90~5.70~6.00	0.90~5.00~5.60	0.90~5.70~5.60
NOMINAL INPUT	Cooling		kW	1.21	1.92	2.19	1.92	2.19
EER				2.81	2.60	2.60	2.60	2.60
ENERGY LABEL	Cooling			C	E	E	E	E
ANNUAL ENERGY CONSUMPTION	Cooling		kWh	605	960	1,095	960	1,095

For combination indoor + outdoor units (air cooled):								
INDOOR UNITS				FCQ35B7V1	FCQ50B7V1	FCQ60B7V1		
OUTDOOR UNITS				RXS35BVMB	RXS50BVMB	RXS60BVMB		
CAPACITY (3)	Cooling	min.-nom.-max.	kW	1.00~3.40~3.70	0.90~5.00~5.60	0.90~5.70~6.00		
	Heating	min.-nom.-max.	kW	1.00~4.10~5.00	0.90~6.00~7.00	0.90~7.00~8.00		
NOMINAL INPUT	Cooling		kW	1.21	1.92	2.19		
	Heating		kW	1.28	1.87	2.19		
EER				2.81	2.60	2.60		
COP				3.20	3.21	3.20		
ENERGY LABEL	Cooling			C	E	E		
	Heating			D	C	D		
ANNUAL ENERGY CONSUMPTION	Cooling		kWh	605	960	1,095		

TECHNICAL SPECIFICATIONS									
For indoor units only:									
INDOOR UNITS				FCQ35B7V1	FCQ50B7V1	FCQ60B7V1			
DIMENSIONS	Unit	H	mm	230					
		W	mm	840					
		D	mm	840					
	Decoration panel	H	mm	40					
		W	mm	950					
		D	mm	950					
WEIGHT	Unit	kg	23						
	Decoration panel	kg	5						
MATERIAL	Unit	Galvanised steel plate							
COLOUR	Decoration panel	White							
SOUND LEVEL	Sound pressure (cooling/heating) (1)	high	dB(A)	31/31			33/33		
		low	dB(A)	27/27			28/28		
	Sound power		dB(A)	48			50		
FAN	Air flow rate (cooling/heating)	high	m <sup>3</sup> /min	14/14	15/15	18/18			
		low	m <sup>3</sup> /min	10/10	11/11	14/14			
	Speed	steps	2 steps						
	Type	Turbo fan							
	Qty x motor output	W	1 x 45						
	Drive	Direct drive							
HEAT EXCHANGER	Type	Cross fin coil $\phi$ 7 HI-XA tubes							
	Rows x stages x fin pitch	mm	2 x 8 x 1.5						
	Face area	m <sup>2</sup>	0.331						
AIR FILTER	Resin net (with mold resistant)								
PIPING CONNECTIONS	liquid	mm	$\phi$ 6.4 (flare)						
		mm	$\phi$ 9.5 (flare)	$\phi$ 12.7 (flare)					
	drain I.D.	mm	$\phi$ 25 (VP25)						
		mm	$\phi$ 32 (VP25)						
INSULATION MATERIAL	Heat insulation	Foamed polystyrene							
	Sound absorbing insulation	Foamed polystyrene							

For outdoor units only:	Pair application	See chapters RS-B + RKS-B + RXS-B
	Multi model application	See chapters 4MKS-B + 3MXS-B/4MXS-B

## 2 Specifications



2

NOMINAL CAPACITY and NOMINAL INPUT					
For indoor units only:					
INDOOR UNITS			FCQ71B7V3B	FCQ100B7V3B	FCQ125B7V3B
NOMINAL INPUT	Cooling	kW	0.161	0.204	0.238
	Heating	kW	0.161	0.204	0.238

For combination indoor + outdoor units (air cooled):					
INDOOR UNITS			FCQ71B7V3B	FCQ100B7V3B	FCQ125B7V3B
OUTDOOR UNITS			RZQ71B7V3B	RZQ100B7V3B	RZQ125B7V3B
CAPACITY (3)	Cooling	min.–nom.–max. kW	*	*	*
	Heating	min.–nom.–max. kW	*	*	*
NOMINAL INPUT	Cooling	min.–nom.–max. kW	*	*	*
	Heating	min.–nom.–max. kW	*	*	*
EER			3.51	3.80	3.37
COP			3.61	3.82	3.49
ENERGY LABEL	Cooling		A	A	A
	Heating		A	A	B
ANNUAL ENERGY CONSUMPTION	Cooling	kWh	*	*	*

TECHNICAL SPECIFICATIONS						
For indoor units only:						
INDOOR UNITS			FCQ71B7V3B	FCQ100B7V3B	FCQ125B7V3B	
DIMENSIONS	Unit	H	mm	230	288	
		W	mm		840	
		D	mm		840	
	Decoration panel	H	mm		40	
		W	mm		950	
		D	mm		950	
WEIGHT	Unit	kg	23		27	
	Decoration panel	kg		5		
MATERIAL	Unit		Galvanised steel plate			
COLOUR	Decoration panel		White			
SOUND LEVEL	Sound pressure (cooling/heating) (3)	high	dB(A)	33/33	37/37	40/40
		low	dB(A)	28/28	32/32	35/35
	Sound power (cooling/heating) (4)		dB(A)	50	53	56
FAN	Air flow rate (cooling/heating)	high	m <sup>3</sup> /min	18/18	28/28	31/31
		low	m <sup>3</sup> /min	14/14	21/21	24/24
	Speed	steps		2 steps		
	Type			Turbo fan		
	Qty x motor output	W		1 x 45		1 x 90
HEAT EXCHANGER	Drive			Direct drive		
	Type			Rhombus type, $\phi$ 7 HI-XA tube		
	Rows x stages x fin pitch	mm	2 x 8 x 1.5		2 x 12 x 1.5	
AIR FILTER	Face area	m <sup>2</sup>	0.331		0.497	
				Resin net (with mold resistant)		
PIPING CONNECTIONS		liquid	mm	$\phi$ 9.5 (flare)		
		gas	mm	$\phi$ 15.9 (flare)		
		drain I.D.	mm	$\phi$ 25 (VP25)		
		drain O.D.	mm	$\phi$ 32 (VP25)		
INSULATION MATERIAL	Heat insulation		Both liquid and gas pipes			

<b>For outdoor units only:</b>	Pair application	See chapter RZQ-B
--------------------------------	------------------	-------------------

\* This information was not available at the time of publication.

## 2 Specifications



2

ELECTRICAL SPECIFICATIONS						
For indoor units only:				FCQ35B7V1	FCQ50B7V1	FCQ60B7V1
CURRENT	Nominal running current	cooling/heating	A	See chapters RS-B + RKS-B + RXS-B		
	Max. running current	cooling/heating	A	See chapters RS-B + RKS-B + RXS-B		

For combination indoor units + outdoor units:				FCQ35B7V1	FCQ50B7V1	FCQ60B7V1	FCQ50B7V1	FCQ60B7V1
				RKS35BVM9	RKS50BVM9	RKS60BVM9	RS50BVM9	RS60BVM9
CURRENT	Nominal running current	cooling	A	See chapter RKS-B			See chapter RS-B	
	Maximum running current	cooling	A	See chapter RKS-B			See chapter RS-B	
	Starting current	cooling	A	See chapter RKS-B			See chapter RS-B	

For combination indoor units + outdoor units:				FCQ35B7V1	FCQ50B7V1	FCQ60B7V1
				RXS35BVM9	RXS50BVM9	RXS60BVM9
CURRENT	Nominal running current	cooling/heating	A	See chapter RXS-B		
	Maximum running current	cooling/heating	A	See chapter RXS-B		
	Starting current	cooling/heating	A	See chapter RXS-B		

For indoor units only:				FCQ35B7V1	FCQ50B7V1	FCQ60B7V1
POWER SUPPLY				V1	V1	V1
NOMINAL DISTRIBUTION SYSTEM VOLTAGE	Phase			1~	1~	1~
	Frequency	Hz		50	50	50
	Voltage	V		230	230	230

3TW25081-1

ELECTRICAL SPECIFICATIONS						
For indoor units only:				FCQ71B7V3B	FCQ100B7V3B	FCQ125B7V3B
CURRENT	Nominal running current	cooling/heating	A	See chapter RZQ-B		
	Max. running current	cooling/heating	A	See chapter RZQ-B		

For combination indoor units + outdoor units:				FCQ71B7V3B	FCQ100B7V3B	FCQ125B7V3B
				RZQ71B7V3B	RZQ100B7V3B	RZQ125B7V3B
CURRENT	Nominal running current	cooling/heating	A	See chapter RZQ-B		
	Maximum running current	cooling/heating	A	See chapter RZQ-B		
	Starting current	cooling/heating	A	See chapter RZQ-B		

For indoor units only:				FCQ71B7V3B	FCQ100B7V3B	FCQ125B7V3B
POWER SUPPLY				V3	V3	V3
NOMINAL DISTRIBUTION SYSTEM VOLTAGE	Phase			1~	1~	1~
	Frequency	Hz		50	50	50
	Voltage	V		230	230	230

3TW25901-1

### NOTES

- Nominal cooling capacities are based on: indoor temperature 27°CDB/19°CWB \* outdoor temperature 35°CDB \* refrigerant piping length: 7.5m \* level difference: 0m.
- Nominal heating capacities are based on: indoor temperature: 20°CDB \* outdoor temperature: 7°CDB/6°CWB \* refrigerant piping length: 7.5m \* level difference 0m.
- Capacities are net, including a deduction for cooling (an addition for heating) for indoor fan motor heat.
- The sound pressure level is measured at 1.5m distance from the unit. It is a relative value, depending on the distance and acoustic environment. For measuring conditions: please refer to item 6 of this chapter.
- The sound power level is an absolute value indicating the "power" which a sound source generates.
- Energy label: scale from A (most efficient) to G (less efficient).
- Annual energy consumption: based on average use of 500 running hours per year at full load (= nominal conditions).



# 3 Dimensional drawings

3

## FCQ35-71B7

Model	A	B
FCQ35B	6.35	9.52
FCQ50B, FCQ60B	6.35	12.70
FCQ71B	9.52	15.90

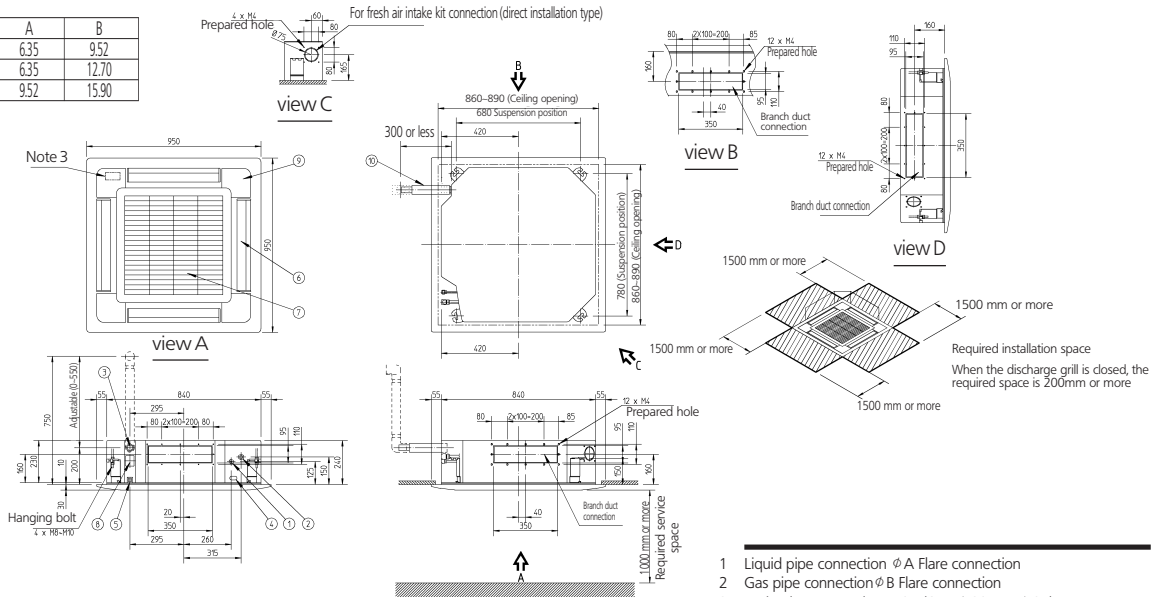

**Note:**

1. Location of unit's name plate  
Main body: bell mouth inside the suction grille.  
Decoration panel: panel inner frame inside the suction grille.
2. When installing an optional accessory, refer to the installation drawings.
  - For fresh air intake kit - inspection port is necessary
  - For high efficiency filter unit - inspection port is not necessary.
  - For branch duct chamber - inspection port is not necessary.

3. In case of using an infrared remote control, this position will be a signal receiver.  
Refer to the drawing of infrared remote control in detail
4. When it may exceed 30°C and RH 80% in the ceiling or fresh air is inducted into the ceiling, an additional insulation (Thickness 10mm or more of glasswool or polyethylene form) is required.

- 1 Liquid pipe connection  $\phi$  A Flare connection
- 2 Gas pipe connection  $\phi$  B Flare connection
- 3 Drain pipe connection VP25 (O.D.  $\phi$  32, I.D.  $\phi$  25)
- 4 Power supply connection
- 5 Transmission wiring connection
- 6 Air discharge grille
- 7 Air suction grille
- 8 Water supply intake
- 9 Corner decoration cover
- 10 Drain hose O.D.  $\phi$  32

3TW22834-1B

## FCQ100-125B7

Model	A	B
FCQ100-125B	9.52	15.90

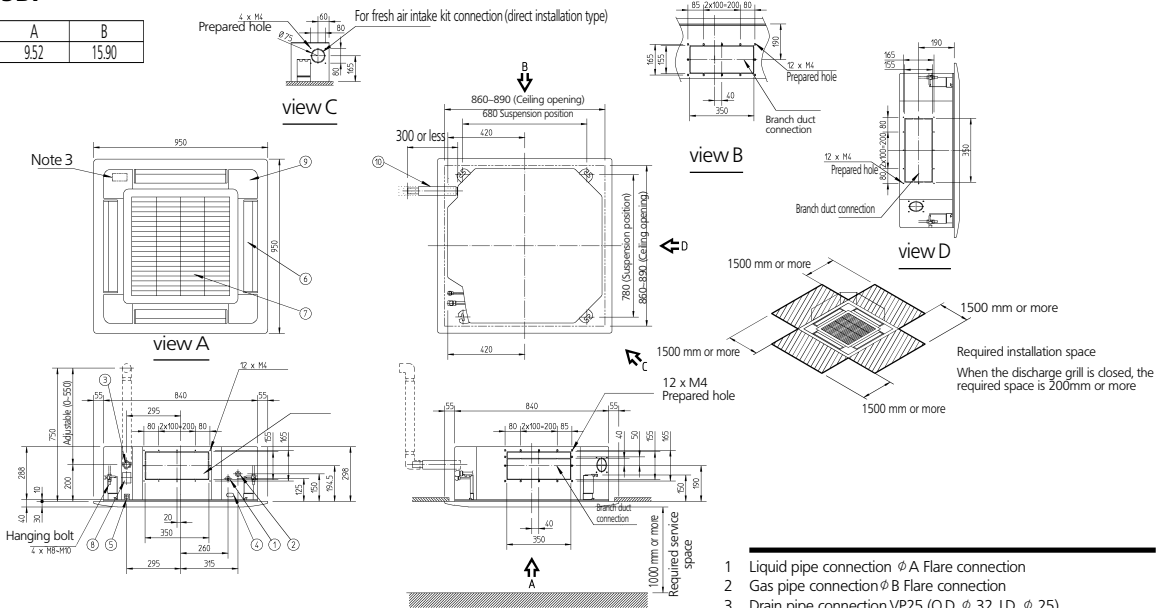

**Note:**

1. Location of unit's name plate  
Main body: bell mouth inside the suction grille.  
Decoration panel: panel inner frame inside the suction grille.
2. When installing an optional accessory, refer to the installation drawings.
  - For fresh air intake kit - inspection port is necessary
  - For high efficiency filter unit - inspection port is not necessary.
  - For branch duct chamber - inspection port is not necessary.

3. In case of using an infrared remote control, this position will be a signal receiver.  
Refer to the drawing of infrared remote control in detail
4. When it may exceed 30°C and RH 80% in the ceiling or fresh air is inducted into the ceiling, an additional insulation (Thickness 10mm or more of glasswool or polyethylene form) is required.

- 1 Liquid pipe connection  $\phi$  A Flare connection
- 2 Gas pipe connection  $\phi$  B Flare connection
- 3 Drain pipe connection VP25 (O.D.  $\phi$  32, I.D.  $\phi$  25)
- 4 Power supply connection
- 5 Transmission wiring connection
- 6 Air discharge grille
- 7 Air suction grille
- 8 Water supply intake
- 9 Corner decoration cover
- 10 Drain hose O.D.  $\phi$  32

3TW22874-1A

6





# 4 Piping diagrams

4

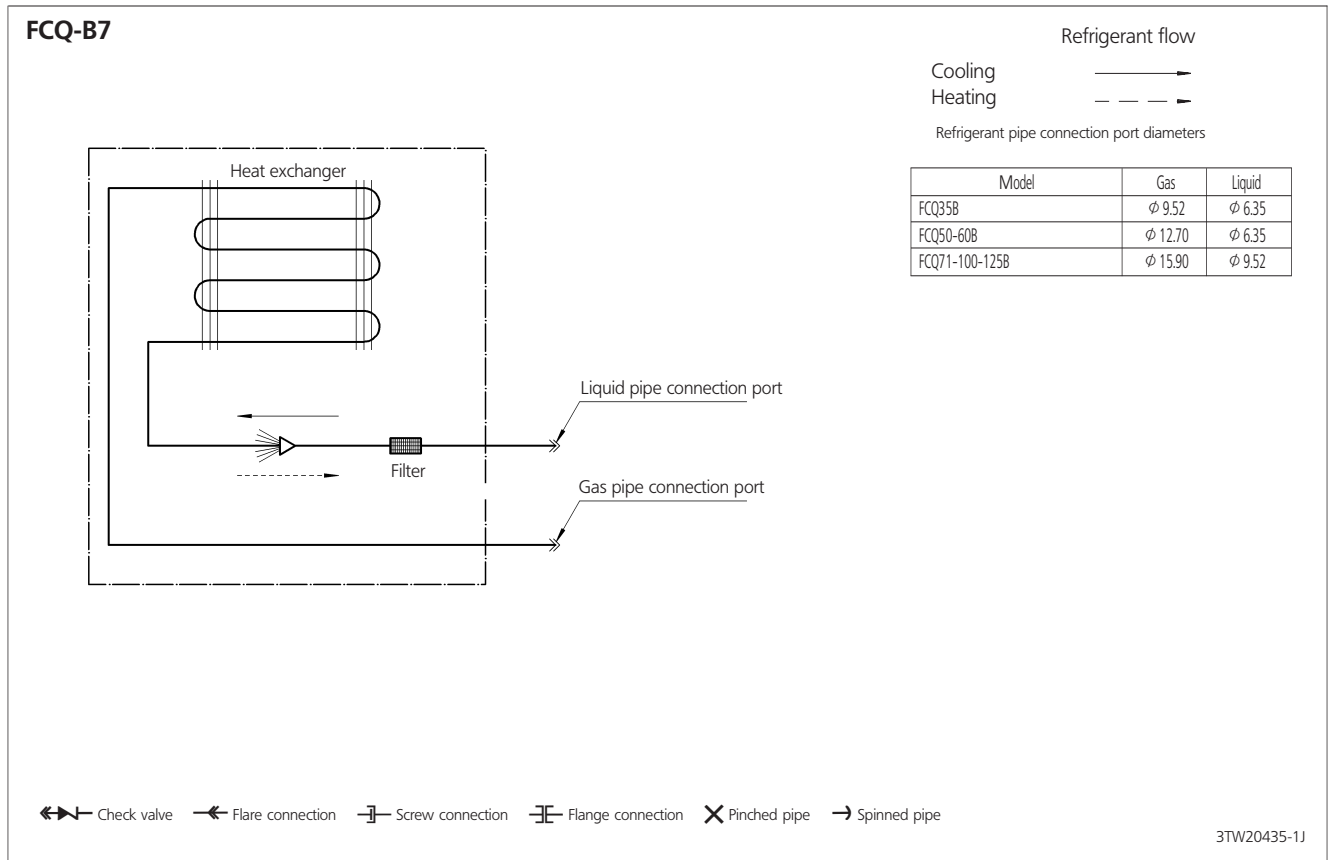

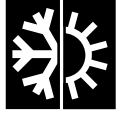

# 5 Wiring diagrams

5

## FCQ35-60B7

**Notes**

1. Use copper conductors only.
2. When using the central remote control, see manual for connection to the unit.
3. X24A is connected when the infrared remote control kit is being used.
4. The infrared remote control model varies according to the combination system. See technical data and catalogues before connecting.

Field wiring Terminal  
 Connector  
 Wire clamp  
 Protective earth (screw)  
 Colours  
 BLK: Black / WHT: White / RED: Red / YLW: Yellow

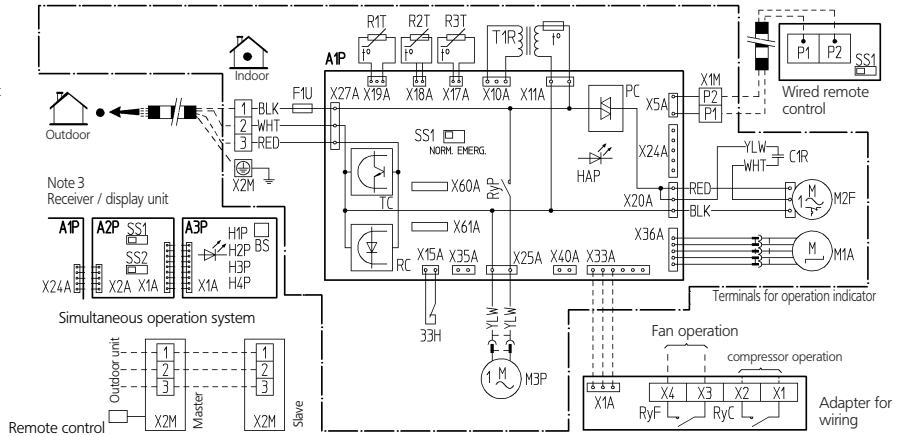
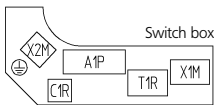

- 33H Float switch
- A1P Printed circuit board
- C1R Capacitor (M2F)
- F1U Fuse (5A, 250V)
- HAP Light emitting diode (service monitor green)
- M1A Motor (swing flap)
- M2F Motor (indoor fan)
- M3P Motor (drain pump)
- Q1F Thermo switch (M2F embedded)
- R1T Thermistor (air)
- R2T Thermistor (liquid)
- R3T Thermistor (coil)

- RyP Magnetic relay (M3P)
- SS1 Selector switch (emergency)
- T1R Transformer (220-240V/22V)
- X1M Terminal strip (power)
- X2M Terminal strip (control)
- H1P Light emitting diode (on-red)
- H2P Light emitting diode (timer-green)
- H3P Light emitting diode (filter sign-red)
- H4P Light emitting diode (defrost-orange)
- SS1 Selector switch (main/sub)

- Receiver / display unit (attached to infrared remote control)
- A2P/A3P Printed circuit board
- BS Push button (on/off)
- H1P Light emitting diode (on-red)
- H2P Light emitting diode (timer-green)
- H3P Light emitting diode (filter sign-red)
- H4P Light emitting diode (defrost-orange)
- SS1 Selector switch (main/sub)
- SS2 Selector switch (wireless address set)

- Adapter for wiring
- RyC/RyF Magnetic relay
- Connector for optional parts
- X60A/X61A Connector (interface adapter for sky air series)
- X33A Connector (adapter for wiring)
- X35A Connector (group control adapter)
- X40A Connector (remote ON/OFF forced OFF)

3TW25086-1A

## FCQ71-125B7

**Notes**

1. Use copper conductors only.
2. When using the central remote control, see manual for connection to the unit.
3. X24A is connected when the infrared remote control kit is being used.
4. The infrared remote control model varies according to the combination system. See technical data and catalogues before connecting.

Field wiring Terminal  
 Connector  
 Wire clamp  
 Protective earth (screw)  
 Colours  
 BLK: Black / WHT: White / RED: Red / YLW: Yellow

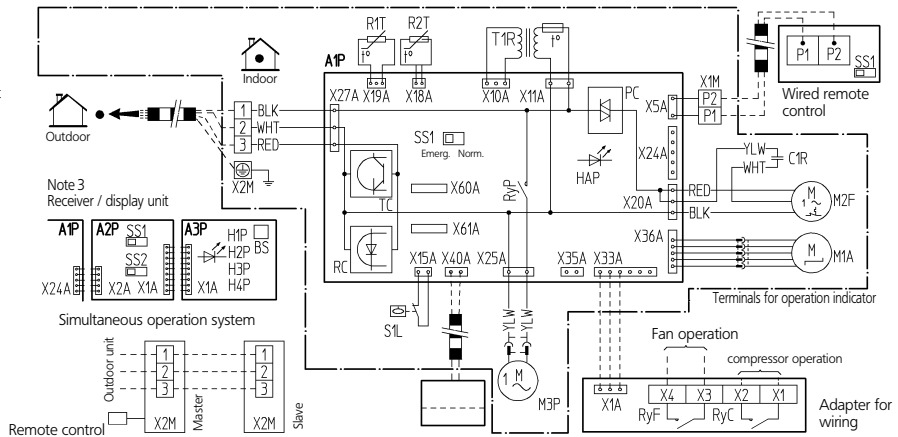
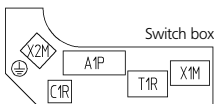

- S1H Float switch
- A1P Printed circuit board
- C1R Capacitor (M2F)
- HAP Light emitting diode (service monitor green)
- M1A Motor (swing flap)
- M2F Motor (indoor fan)
- M3P Motor (drain pump)
- Q1F Thermo switch (M2F embedded)
- R1T Thermistor (air)
- R2T Thermistor (liquid)

- RyP Magnetic relay (M3P)
- SS1 Selector switch (emergency)
- T1R Transformer (220-240V/22V)
- X1M Terminal strip (power)
- X2M Terminal strip (control)
- H1P Light emitting diode (on-red)
- H2P Light emitting diode (timer-green)
- H3P Light emitting diode (filter sign-red)
- H4P Light emitting diode (defrost-orange)
- SS1 Selector switch (main/sub)

- Receiver / display unit (attached to infrared remote control)
- A2P/A3P Printed circuit board
- BS Push button (on/off)
- H1P Light emitting diode (on-red)
- H2P Light emitting diode (timer-green)
- H3P Light emitting diode (filter sign-red)
- H4P Light emitting diode (defrost-orange)
- SS1 Selector switch (main/sub)
- SS2 Selector switch (wireless address set)

- Adapter for wiring
- RyC/RyF Magnetic relay
- Connector for optional parts
- X60A/X61A Connector (interface adapter for sky air series)
- X33A Connector (adapter for wiring)
- X35A Connector (group control adapter)
- X40A Connector (remote ON/OFF forced OFF)

3TW25906-1

8



# 6 Sound level

## 6-1 Sound level data

Model	Sound pressure level		Measuring location	Sound power level (H) (cooling/heating)
	230V, 50Hz			
	Cooling/Heating			
	H	L		
FCQ35B7V1	31	27		48
FCQ50B7V1	31	27		48
FCQ60B7V1	33	28		50
FCQ71B7V3B	33	28		50
FCQ100B7V3B	37	32		53
FCQ125B7V3B	40	35		56

6

6-1

## 6-2 Sound pressure spectrum

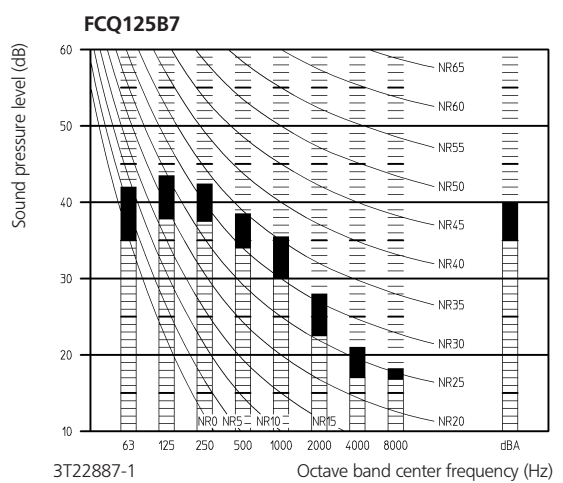
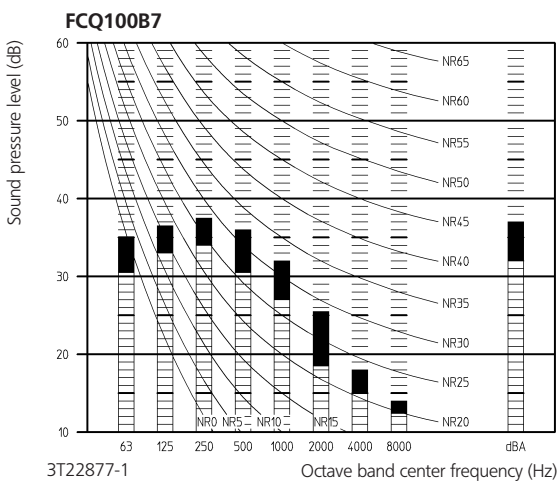
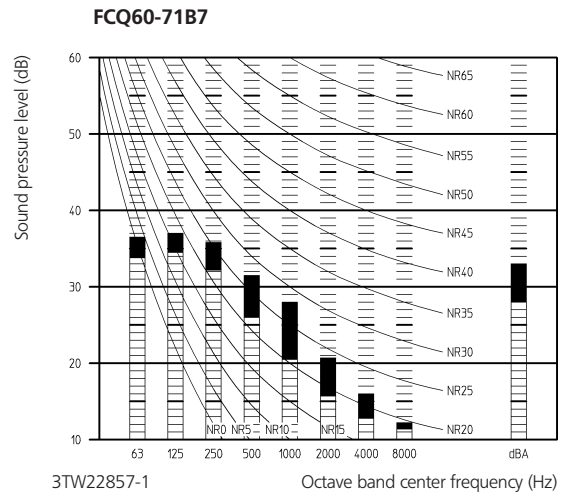
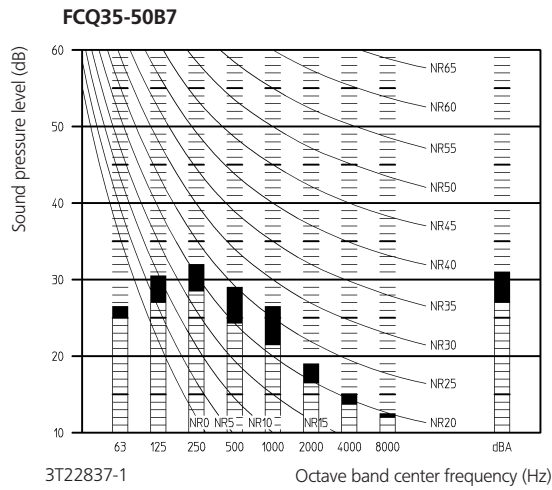

### NOTES

- 1 Data is valid at free field condition
- 2 Operation sound levels are valid at nominal operation condition 230V
- 3 dB(A) = A-weighted sound pressure level (A-scale according to IEC)
- 4 Reference acoustic pressure 0dB = 20μPa

### Legend

- High speed
- Low speed



# 7 Air flow patterns

## 7 FCQ35B7

Heating - air velocity distribution

4-way discharge, air flow direction: down

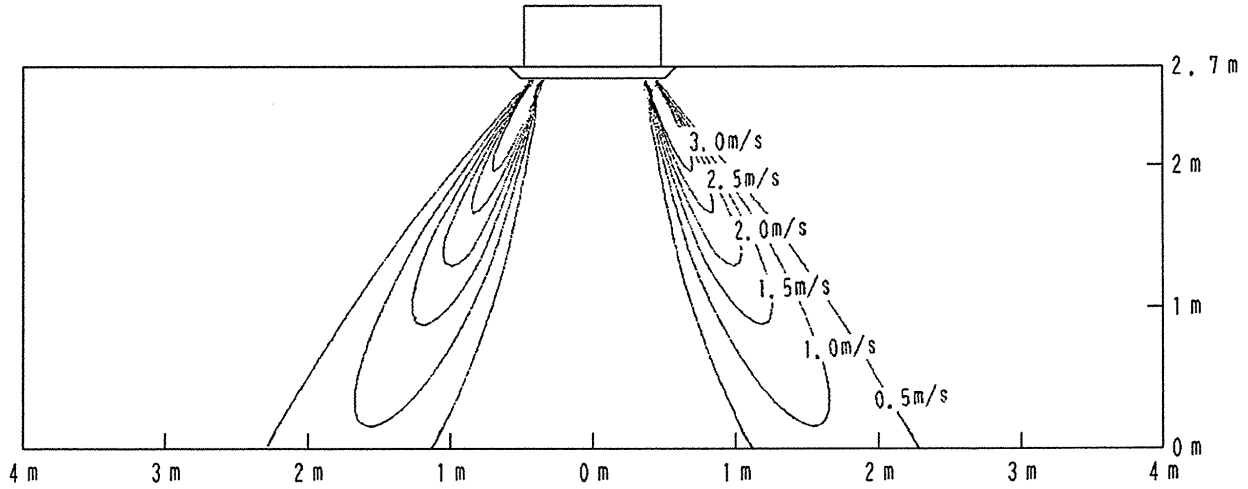

## FCQ35B7

Heating - air temperature distribution

4-way discharge, air flow direction: down

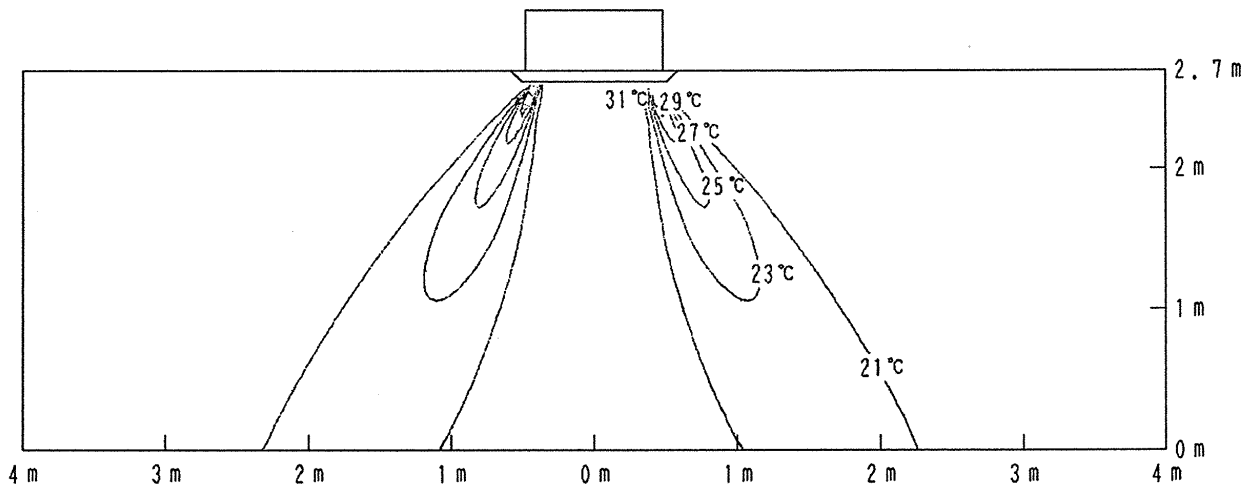

4D024116

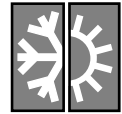

# 7 Air flow patterns

**FCQ50B7**

Heating - air velocity distribution

4-way discharge, air flow direction: down

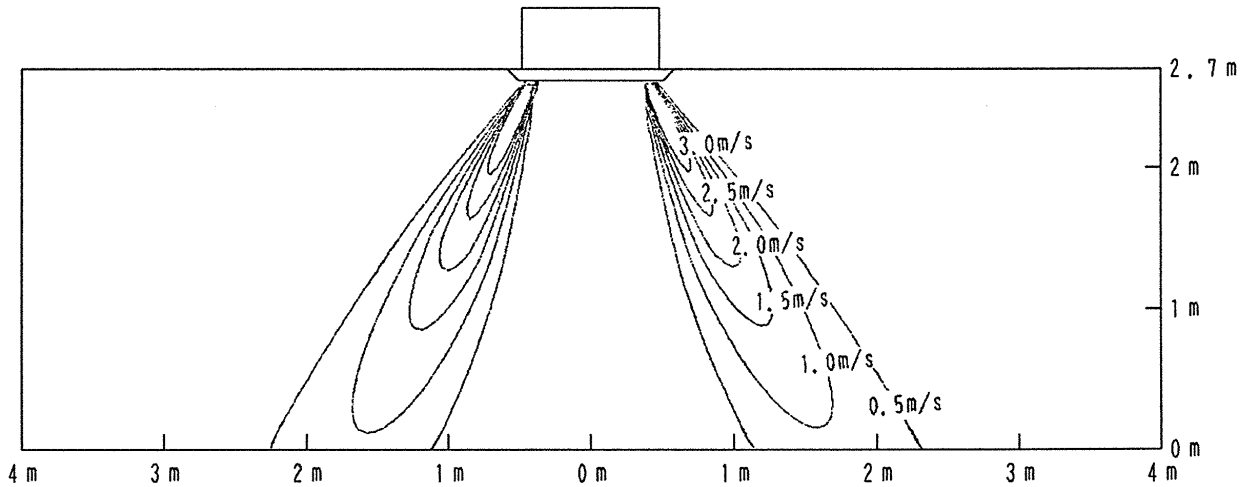

**FCQ50B7**

Heating - air temperature distribution

4-way discharge, air flow direction: down

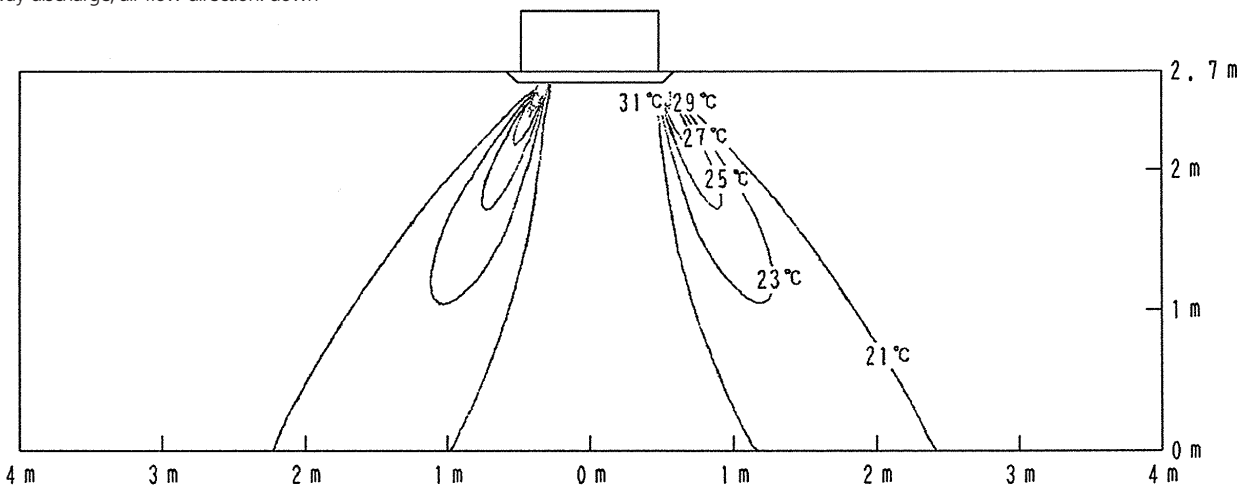

4D024117



# 7 Air flow patterns

## 7 FCQ60-71B7

Heating - air velocity distribution

4-way discharge, air flow direction: down

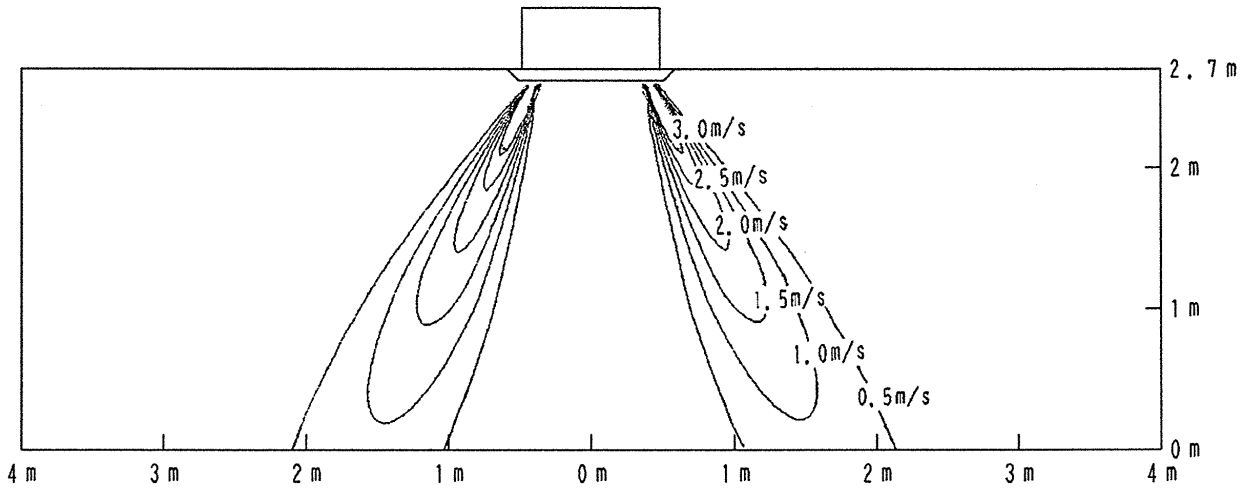

## FCQ60-71B7

Heating - air temperature distribution

4-way discharge, air flow direction: down

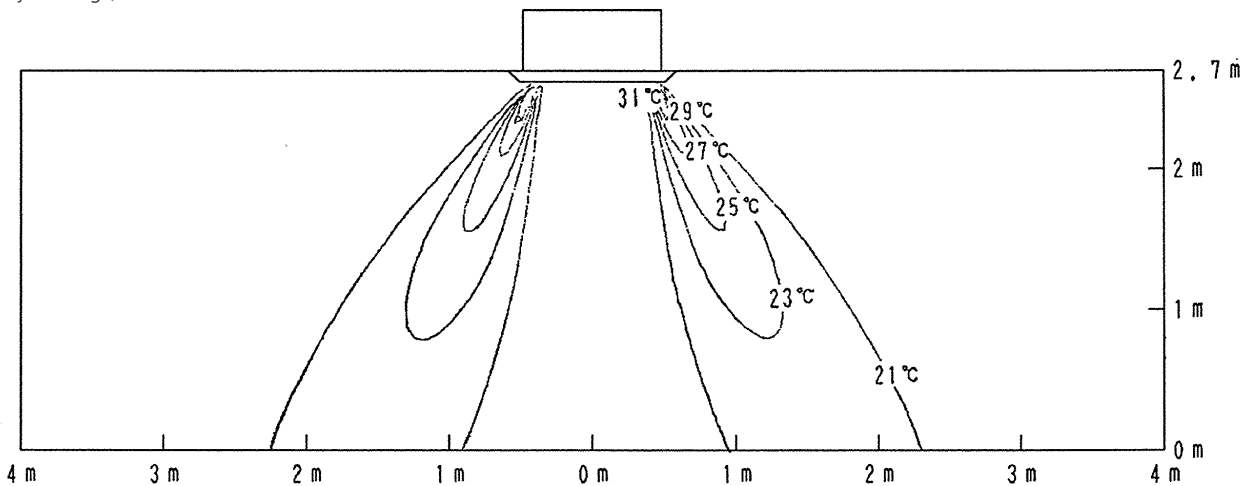

4D024118



# 7 Air flow patterns

## FCQ100-125B7

Heating - air velocity distribution

4-way discharge, air flow direction: down

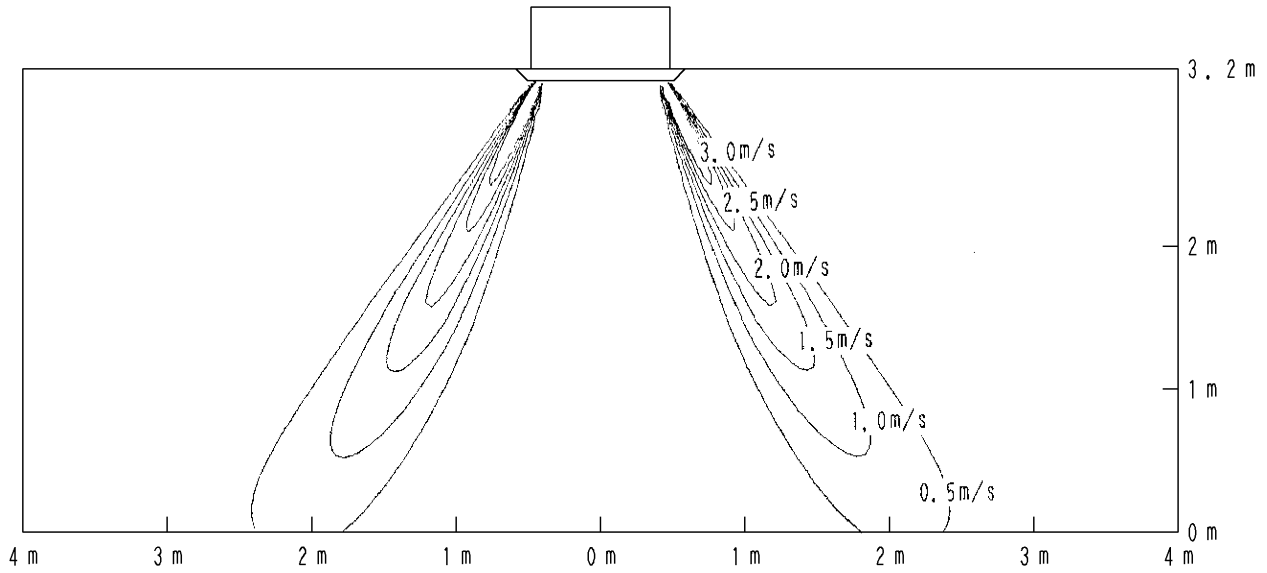

## FCQ100-125B7

Heating - air temperature distribution

4-way discharge, air flow direction: down

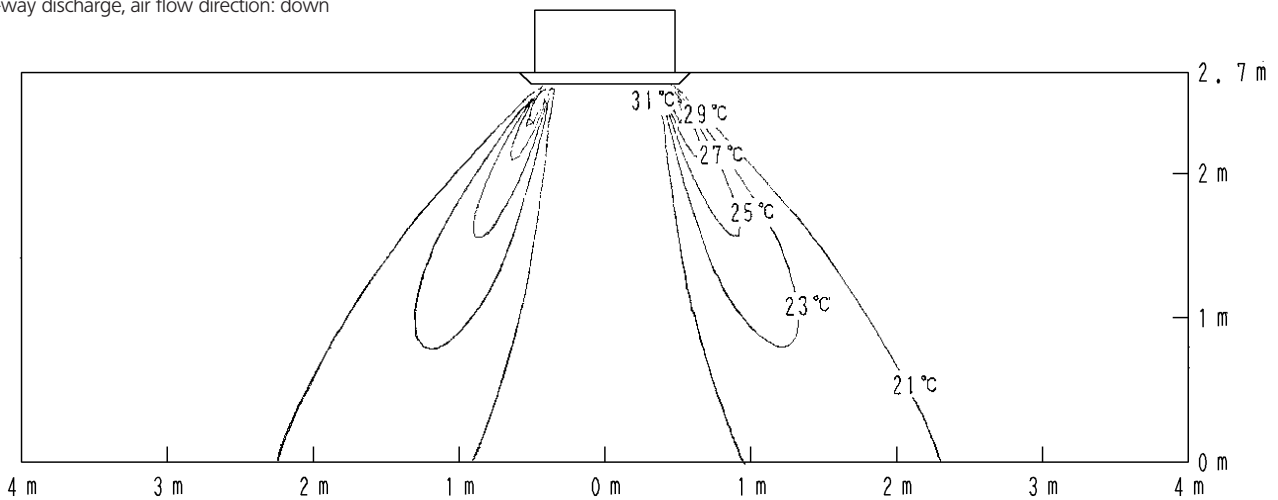

4D024119



# 8 Branch duct connections

## 8 FCQ-B7

### 1 branch duct - 3 way blow

Discharge grill: K-DGSC4B (connection: diameter 150mm)  
 Flexible duct K-FDK154B (connection: diameter 150mm, length: 4m)  
 Air volume: 1,5-2,0 m<sup>3</sup>/min

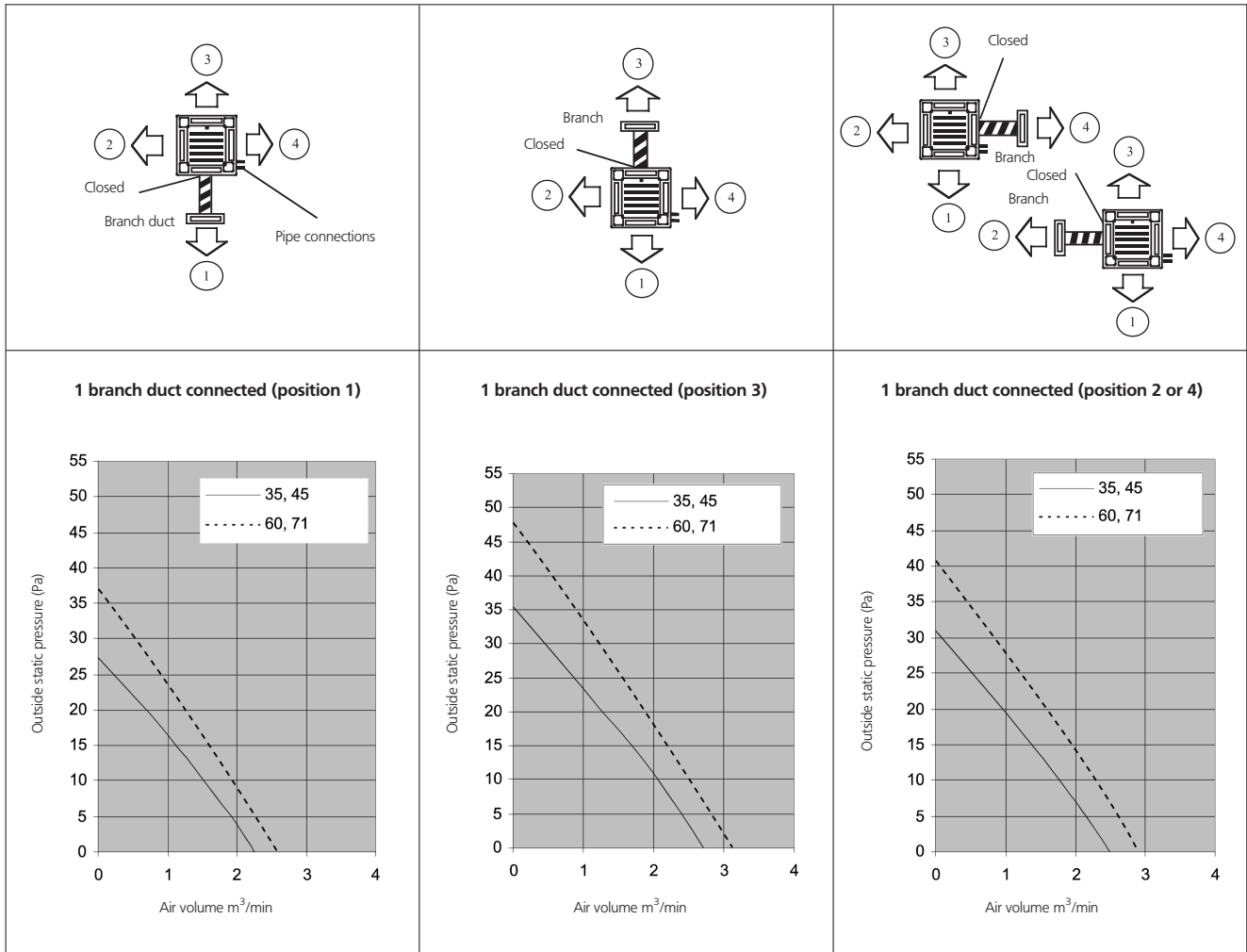

3TW22839-7



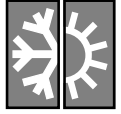

# 8 Branch duct connections

## FCQ-B7

### 1 branch duct - 2 way blow

Discharge grill: K-DGSC4B (connection: diameter 150mm)  
 Flexible duct K-FDK154B (connection: diameter 150mm, length: 4m)  
 Air volume: 2,0-3,0 m<sup>3</sup>/min

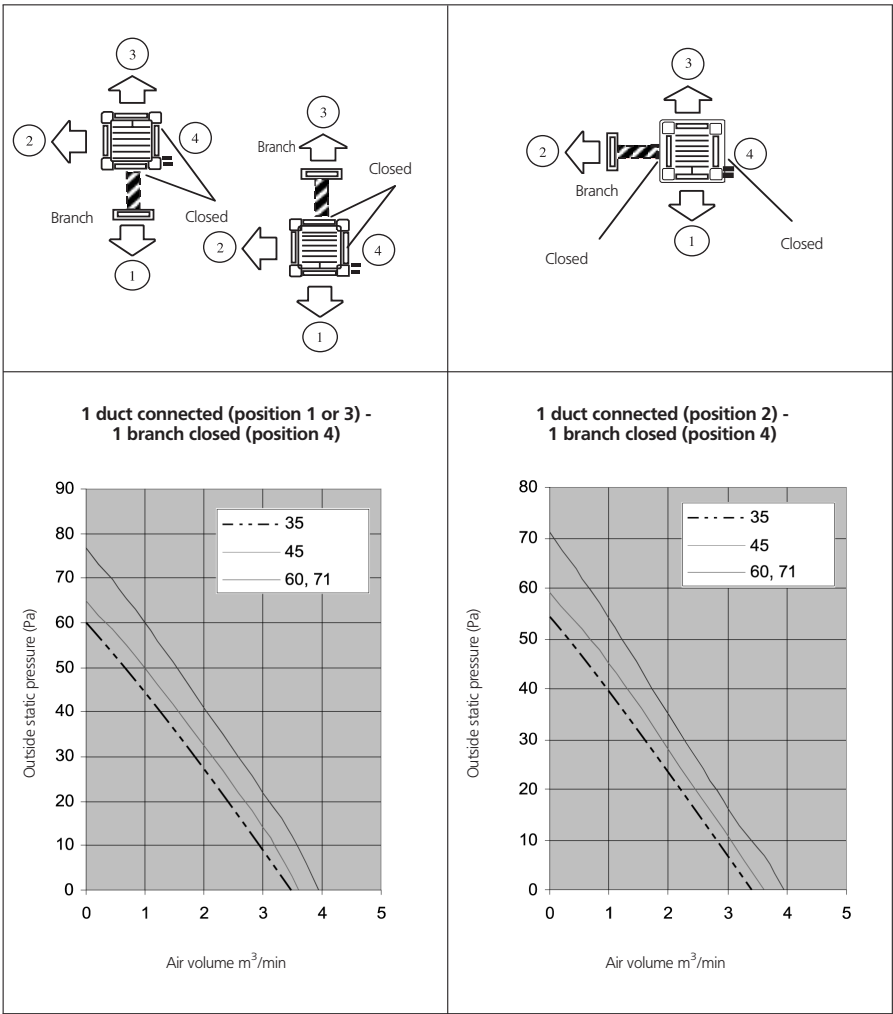

3TW22839-8



# 8 Branch duct connections

## 8 FCQ-B7

### 2 branch duct - 2 way blow

Discharge grill: K-DGSC4B (connection: diameter 150mm)  
 Flexible duct K-FDK154B (connection: diameter 150mm, length: 4m)  
 Air volume: 4,0-5,0 m<sup>3</sup>/min

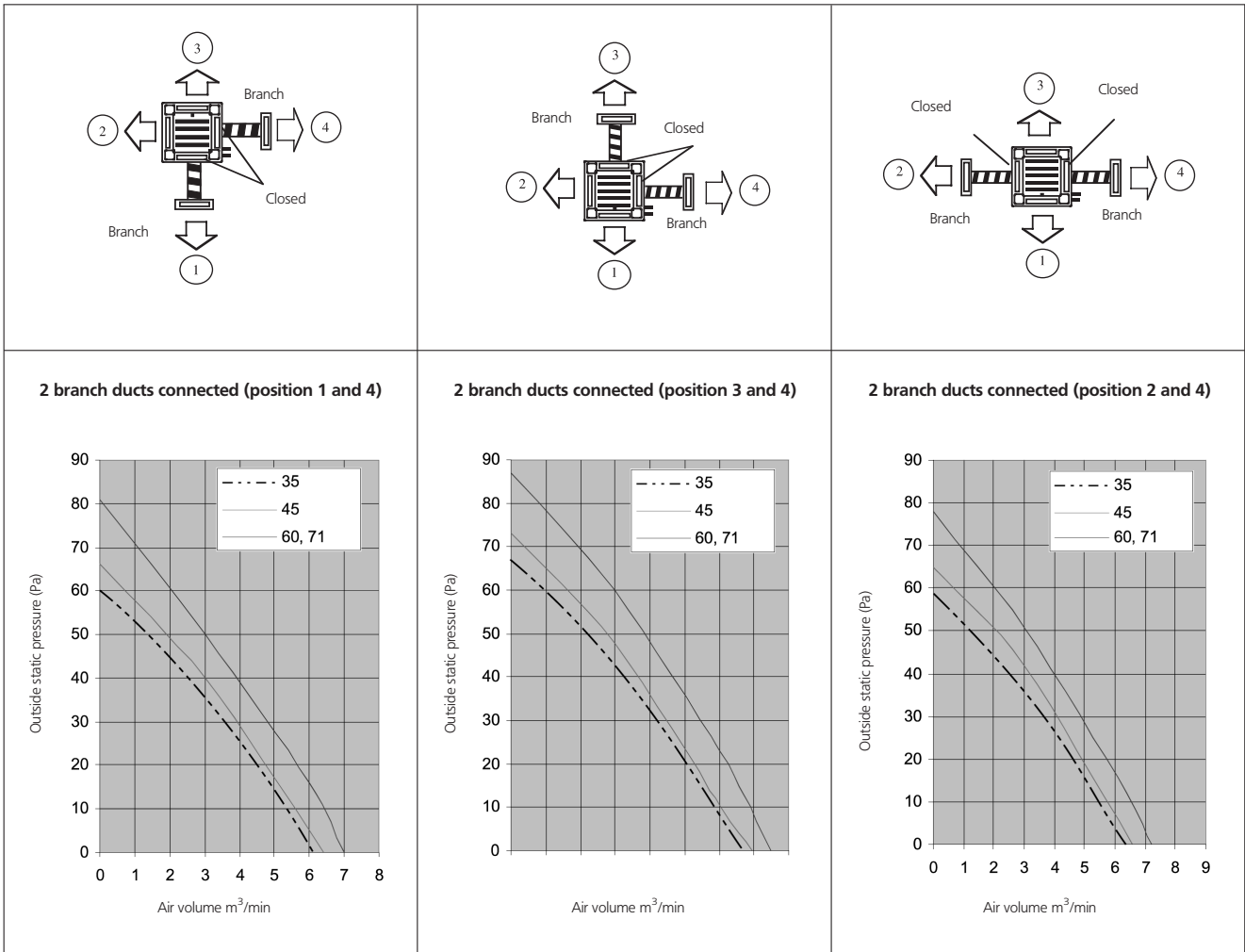

3TW22839-9



# 8 Branch duct connections

## FCQ-B7

### 1 branch duct - 3 way blow

Discharge grill: K-DGSC4B (connection: diameter 200mm)  
 Flexible duct: K-FDK154B (connection: diameter 200mm, length: 6m)  
 Air volume: 5,0-7,0 m<sup>3</sup>/min

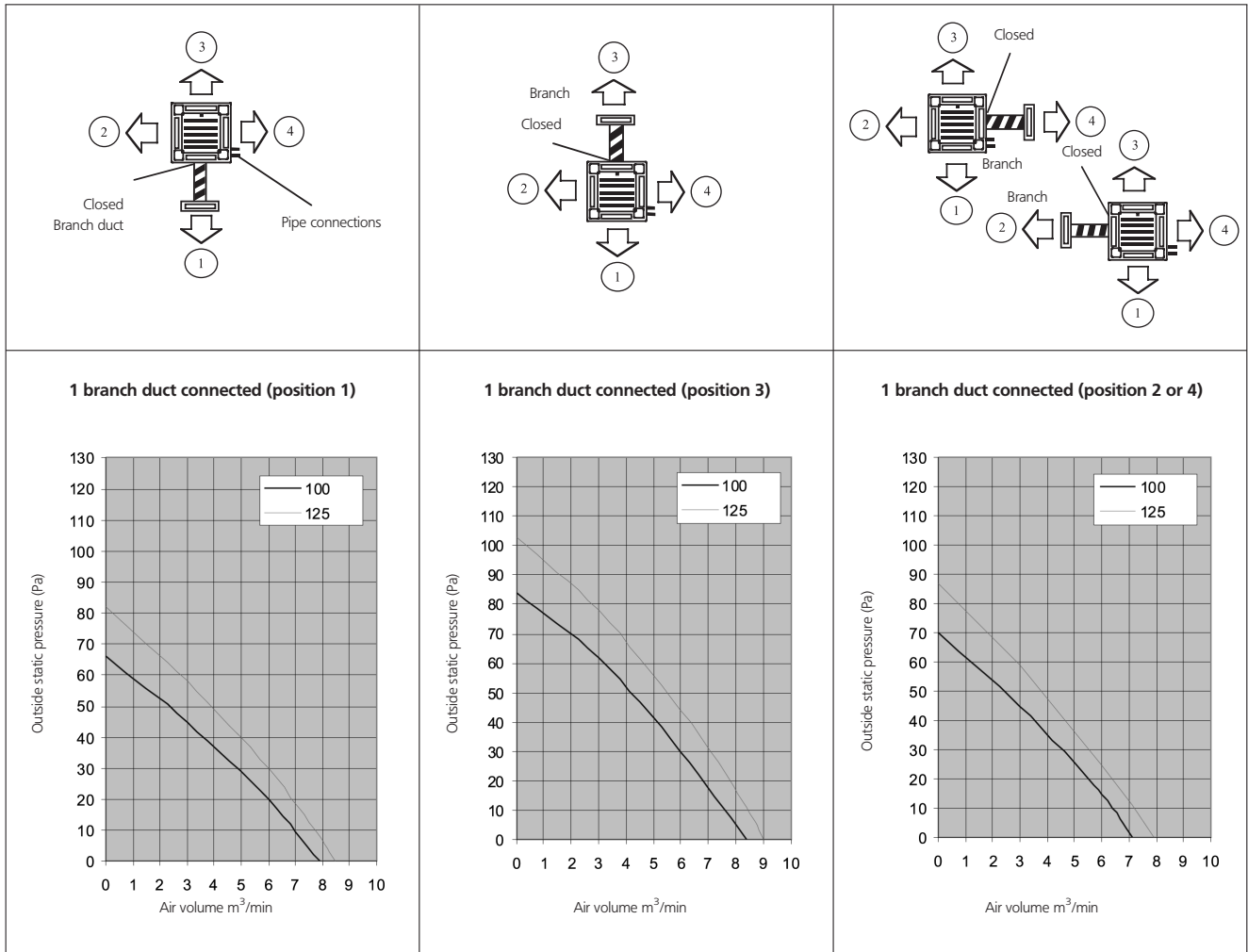

3TW22879-7



# 8 Branch duct connections

## 8 FCQ-B7

### 1 branch duct - 2 way blow

Discharge grill: K-DGSC4B (connection: diameter 200mm)  
 Flexible duct: K-FDK154B (connection: diameter 200mm, length: 6m)  
 Air volume: 7,0-10,0 m<sup>3</sup>/min

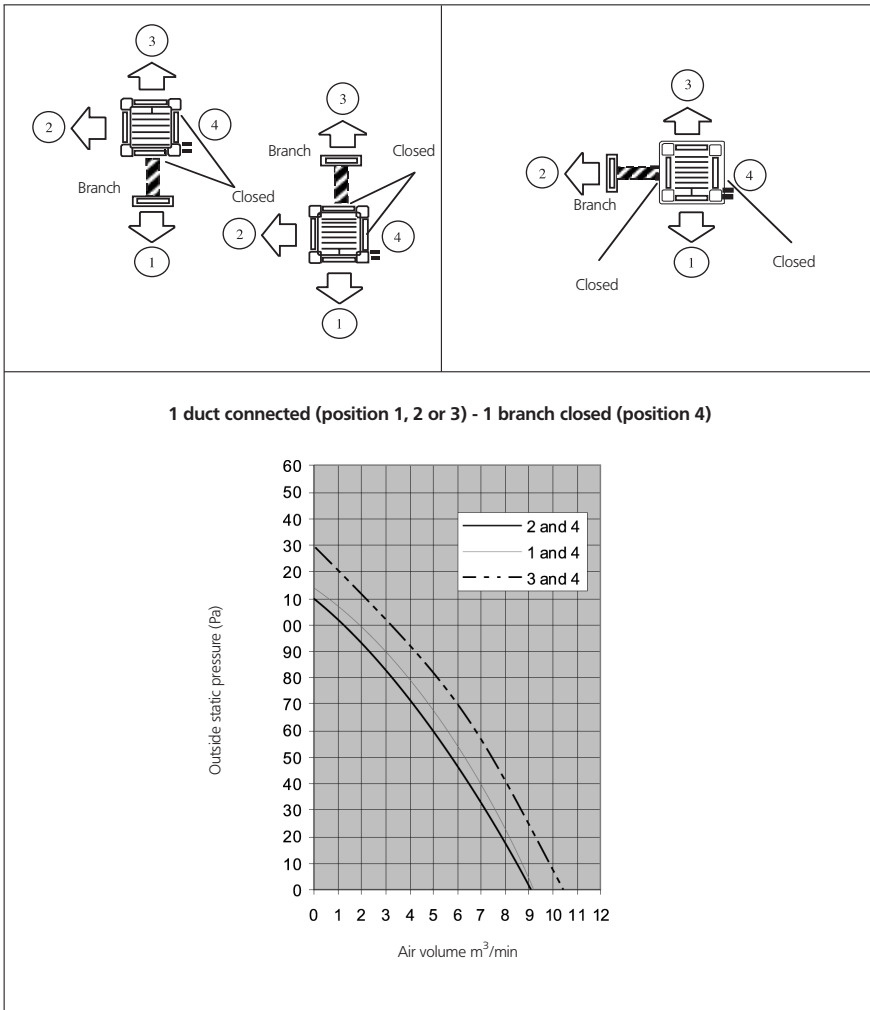

3TW22879-8

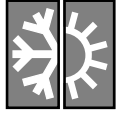

# 8 Branch duct connections

## FCQ-B7

### 2 branch duct - 2 way blow

Discharge grill: K-DGSC4B (connection: diameter 200mm)  
 Flexible duct: K-FDK154B (connection: diameter 200mm, length: 6m)  
 Air volume: 9,0-11,0 m<sup>3</sup>/min

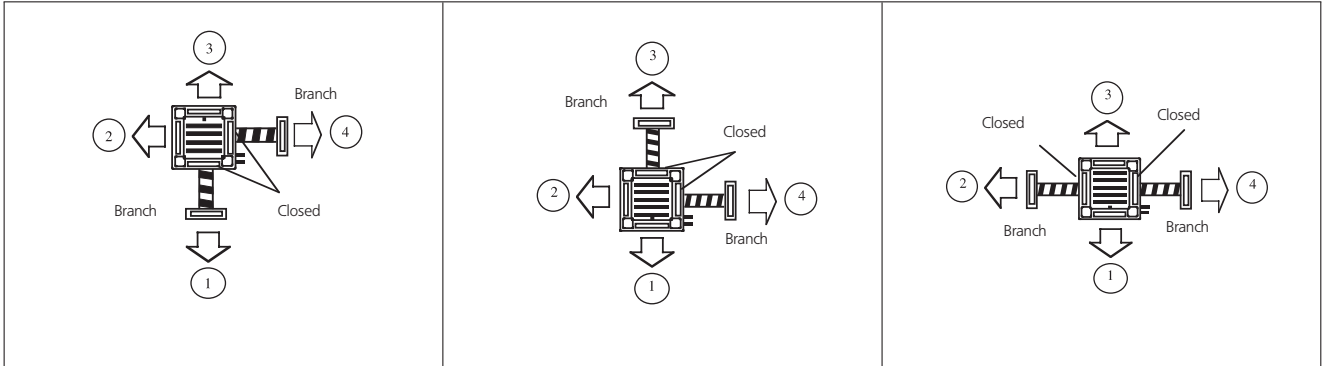

2 branch ducts connected (4 and 1 or 4 and 2 or 4 and 3)

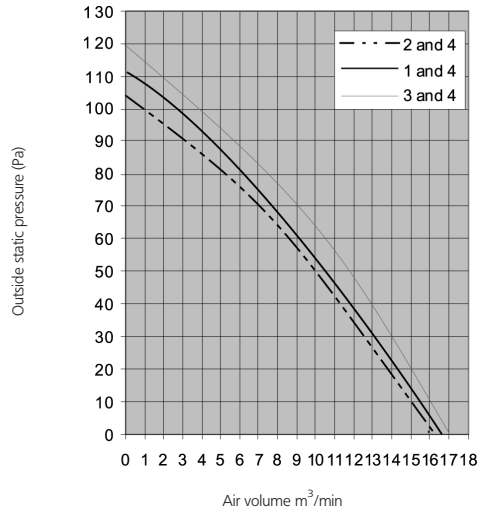

3TW22879-9











# 9 Accessories

## 9-1 Standard accessories

### 9

Check if the following accessories are included with your unit.

9-1

 <p>Clamp 1 pc.</p>	<p>Also used as packing material</p>  <p>Paper pattern for installation 1 pc.</p>	 <p>Drain hose 1 pc.</p>
 <p>Screws M5 For paper pattern for installation 4 pcs.</p>	 <p>Washer for hanging bracket 8 pcs.</p>	 <p>Sealing 2 pcs.</p>
<p>Insulation for fitting 1 of each</p>  <p>For gas pipe</p>  <p>For liquid pipe</p>		<p>Other: installation manual, operation manual</p>

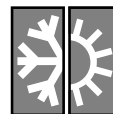

# 9 Accessories

## 9-2 Optional accessories

9

9-2

### Options

Item	Model		FCQ35	FCQ50	FCQ60	FCQ71	FCQ100	FCQ125	
Decoration panel			BYC125KW1						
Filter related	High efficiency filter 65%	Colorimetric method	KAFJ556K80				KAFJ556K160		
	High efficiency filter 90%	Colorimetric method	KAFJ557K80				KAFJ557K160		
	Replacement high efficiency filter 65%	Colorimetric method	KAFJ552K80				KAFJ552K160		
	Replacement high efficiency filter 90%	Colorimetric method	KAFJ553K80				KAFJ553K160		
	Filter chamber		KDDFJ55K160						
	Replacement long-life filter	Non-woven type	KAFJ551K160						
	Ultra-long life filter		KAFJ55K160						
	Replacement ultra long-life filter		KAFJ55K160H						
Fresh air intake kit	Chamber type	Without T-shape and fan	KDDJ55B160						
		With T-shape, and fan	KDDJ55B160F						
		With T-shape, without fan	KDDJ55B160K						
	Direct installation type		KDDJ55X160						
Sealing member of air discharge outlet			KDBHJ55B160						
Panel spacer			KDBJ55K160W						
Branch duct chamber			KDJ55B80			KDJ55B160			
Chamber connection kit			KKSJ55K160						

### Control systems

Item	Model		FCQ35	FCQ50	FCQ60	FCQ71	FCQ100	FCQ125
Remote control	Infrared	Heat pump	BRC7C512W					
		Cooling only	BRC7C513W					
	Wired		BRC1D527					
Wiring adaptor for electrical appendices *1			KRP1B57					
Wiring adaptor for electrical appendices *1			KRP4A53					
Wiring adapter (hour meter) *2			EKRP1B2					
Remote sensor			KRCS01-1					
Installation box for adaptor PCB			KRP1C98					
Central remote control			DCS302B51					
Electrical box with earth terminal (3 blocks)			KJB311A					
Unified ON/OFF control			DCS301B51					
Electrical box with earth terminal (2 blocks)			KJB212A					
Noise filter (for electromagnetic interface use only)			KEK26-1					
Schedule timer			DST301B51					
Interface adapter for Sky Air series			DTA112B51					
Remote ON/OFF, forced OFF			EKRORO					

\*1 Installation box for adaptor PCB (KRP1C98) is necessary

\*2 Possibility to connect an hour meter. This part should not be installed inside the equipment.

3TW25089-1B

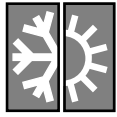

# 9 Accessories

## 9-2 Optional accessories

### 9 FCQ-B7

9-2

#### Fresh air intake kit

##### 1. Option kits KDDJ55B160, KDDJ55B160K, KDDJ55B160F

Following restrictions must be kept:

1. Maximum 20% of the nominal indoor unit air volume can be sucked from the fresh air duct.
2. Put an air filter in the duct.
3. When a duct fan is used, use the option kit together with the duct fan. When only the duct fan is operating, dust can fall from the air filter into the room.

Adapter for wiring KRP1B57  
Installation box for adaptor PCB (KRP1C98) is necessary

##### 2. Option kit KDDJ55X160

This kit can be used when the duct length is less than 4 m.  
Approximately 2 or 3% of the nominal indoor unit air volume can be sucked from the fresh air duct.

The use of a duct fan is not allowed because the sound of the duct can be heard at the indoor unit.

Option kit	Fresh air intake volume / static pressure
KDDJ55B160 (without T-joint connection and without duct fan)	
KDDJ55B160K (with T-joint connection, without duct fan)	
KDDJ55B160F (with T-joint connection and with duct fan)	
KDDJ55X160 (direct installation)	

3TW22839-10A





# 10 Control systems

## 10-1 Wired remote control

10

10-1

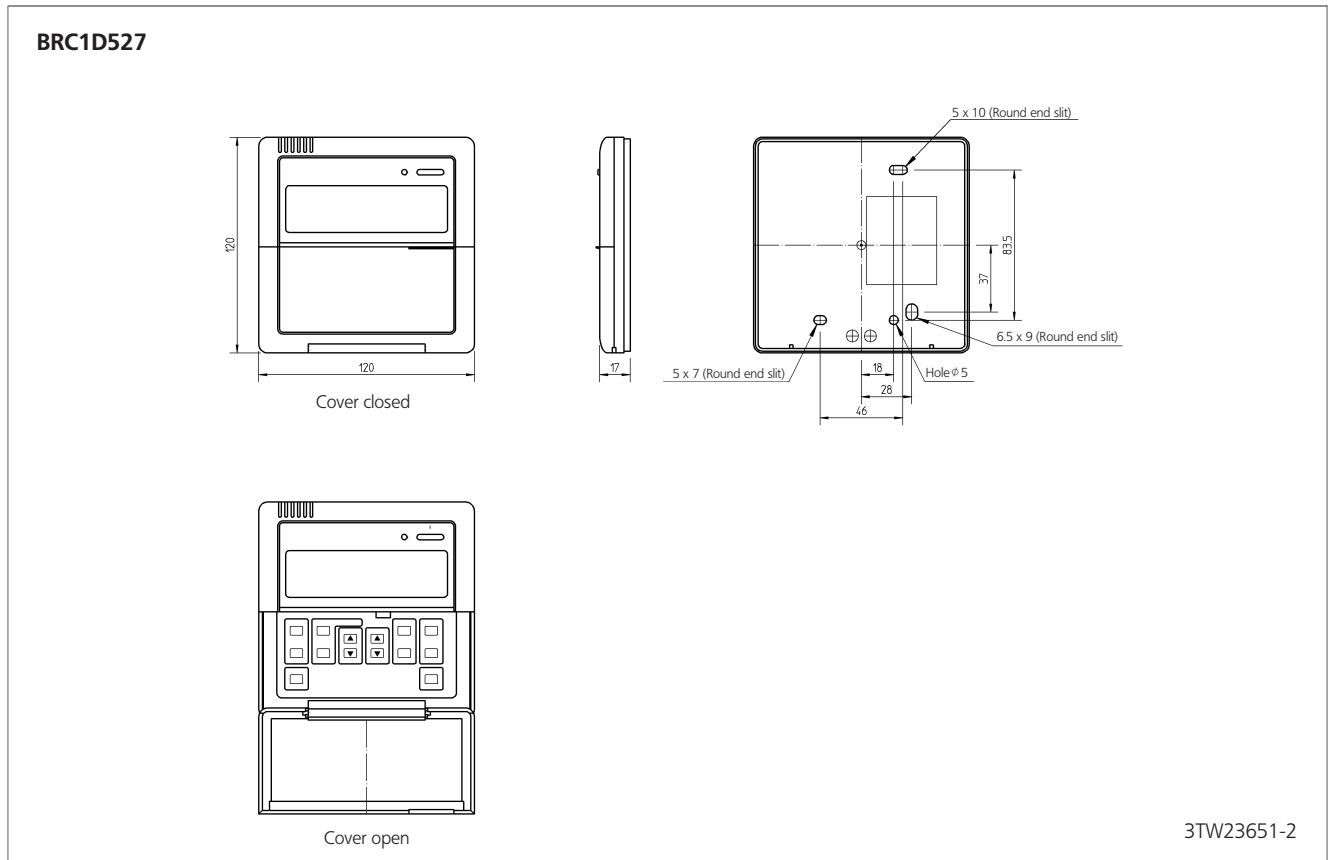



# 11 Center of gravity

## 11 FCQ-B7

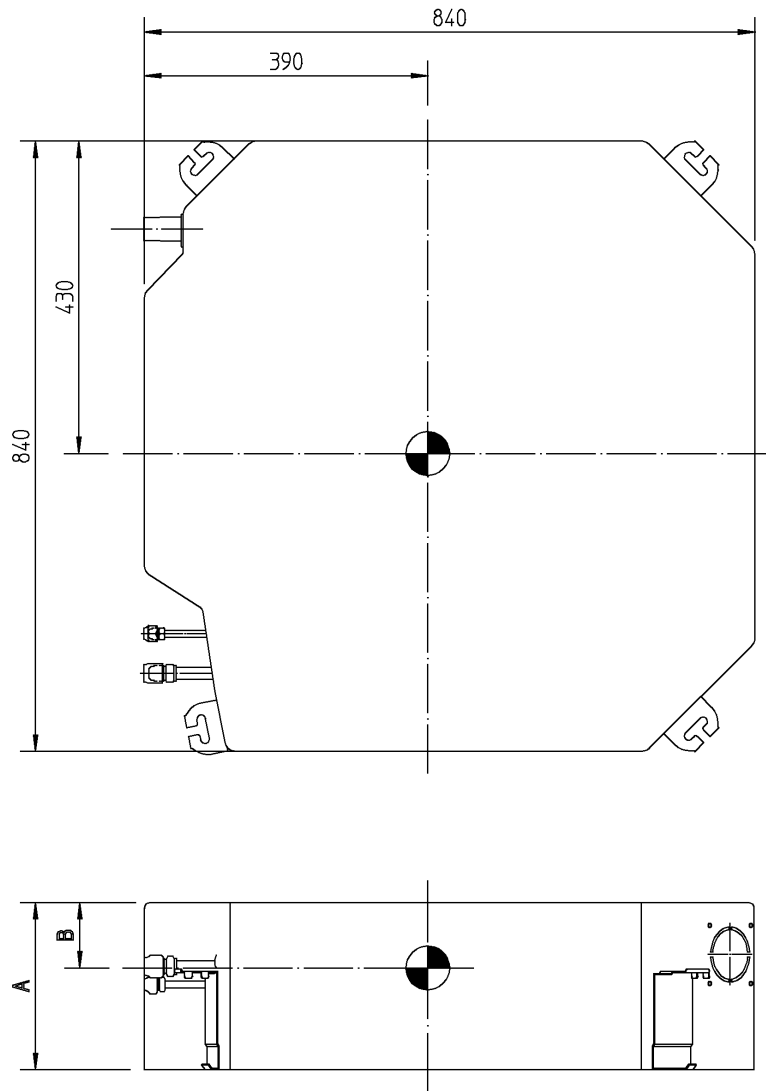

Model	A	B
FCQ35-71B	230	90
FCQ100-125B	288	120

4TW22839-2B

# 12 Safety device settings

Model	Safety devices	35	45	60	71	100	125
FCQ-B	Fan motor thermal protector (°C)	OFF: 130±5 ON: 80±20	OFF: 130±5 ON: 80±20	OFF: 130±5 ON: 80±20	OFF: 130±5 ON: 80±20	OFF: 130±5 ON: 80±20	OFF: 130±5 ON: 80±20
	Drain pump fuse (°C)	145	145	145	145	145	145

3TW22831-3B



# 13 Installation

FCQ-B7

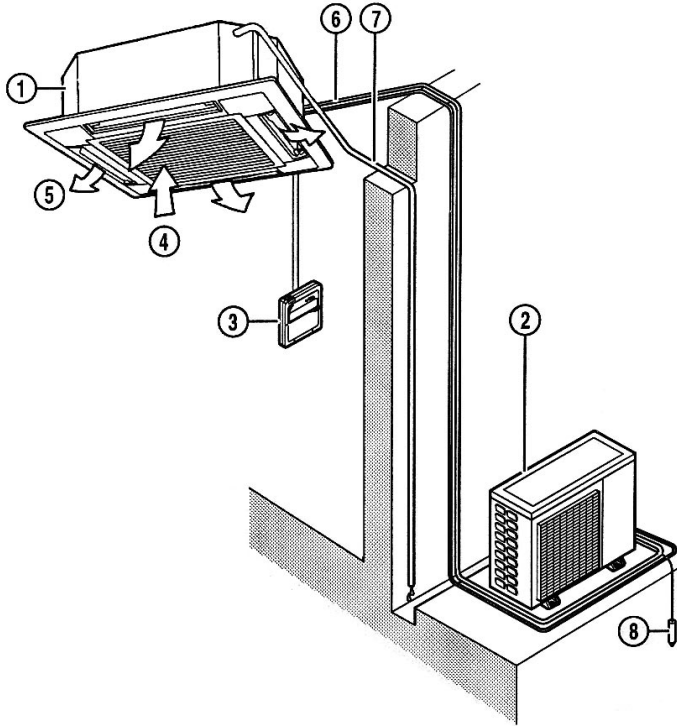

Number	Description
1	Indoor unit
2	Outdoor unit
3	Remote control
4	Inlet air
5	Discharged air
6	Refrigerant piping, connection electric wire
7	Drain pipe
8	Ground wire Wire to ground from the outdoor unit to prevent electrical shocks.