



technical data

FCQ-D

**4-way Blow Ceiling
Mounted Cassette
(950mm x 950mm)**



air conditioning systems

Split
Sky Air

Split - Sky Air



ISO14001 assures an effective environmental management system in order to help protect human health and the environment from the potential impact of our activities, products and services and to assist in maintaining and improving the quality of the environment



Daikin units comply with the European regulations that guarantee the safety of the product.



Daikin Europe N.V. is approved by LRQA for its Quality Management System in accordance with the ISO9001 standard. ISO9001 pertains to quality assurance regarding design, development, manufacturing as well as to services related to the product.



Daikin Europe N.V. participates in the Eurovent Certification Programme for Air Conditioners (AC), Liquid Chilling Packages (LCP) and Fan Coil Units (FC); the certified data of certified models are listed in the Eurovent Directory.

Specifications are subject to change without prior notice.

DAIKIN EUROPE N.V.

Zandvoordestraat 300
B - 8400 Ostend Belgium
www.daikineurope.com

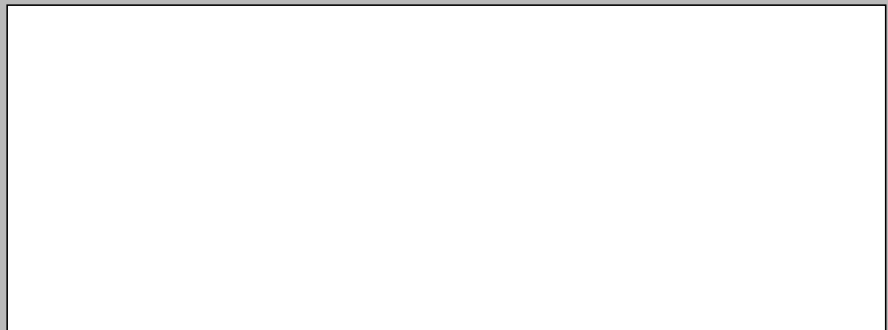

TABLE OF CONTENTS

FCQ-D

1	Features.....	2
2	Specifications.....	3
	Nominal capacity and power input	3
	Technical Specifications	3
	Electrical Specifications	4
3	Options.....	5
4	Dimensional drawing.....	6
	Dimensional drawing	6
5	Piping diagram.....	7
6	Wiring diagram	8
	Wiring diagram	8
	External connection diagram	8
7	Sound data.....	9
	Sound pressure spectrum	9
8	Air flow pattern.....	10
	10

1 Features

1

- Compact & stylish
- Ideal for shops, restaurants or offices requiring maximum floor space for furniture, decorations and fittings
- Fits flush into each ceiling
- Extremely quiet in operation
- Air can be discharged in any of 4 directions
- Possibility to shut 1 or 2 flaps for easy installation in corners or to use 1 or 2 branches
- Air flow distribution for ceiling heights up to 4.2m without loss of capacity.
- Daikin remote controls give you easy control at your fingertips.
- The wired remote control provides you with a schedule timer, enabling to program the air conditioning daily or weekly.
- The optional remote ON/OFF enables you to start/stop the air conditioning from a mobile phone via a telephone remote control (field supply).
- The optional forced OFF enables you to switch off the unit automatically. E.g. when a window is opened, the unit switches off.
- The 'home leave' operation button prevents large temperature differences by continuously operating at a minimum (heating mode) or maximum (cooling mode) preset level while you're out or sleeping. It also allows the indoor temperature to return quickly to your favourite comfort level.

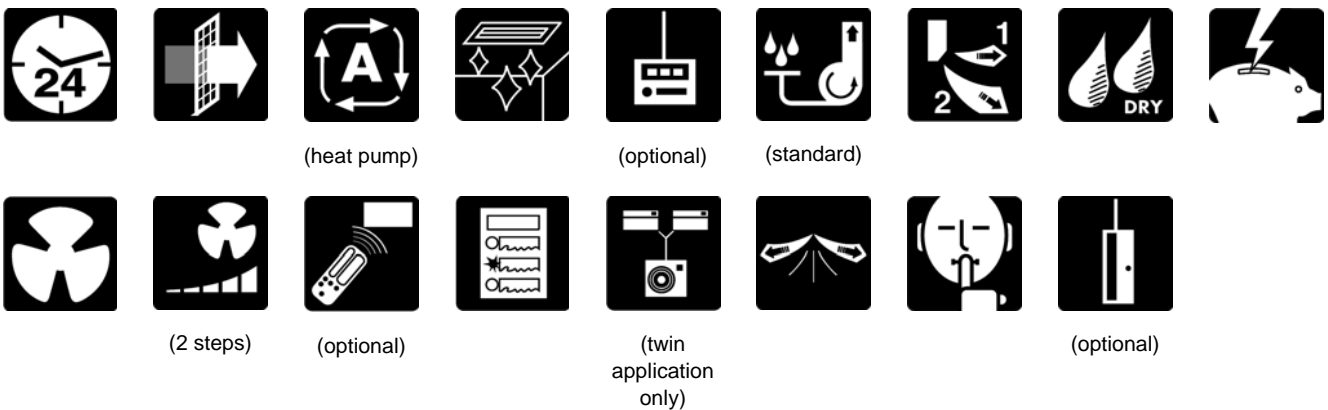
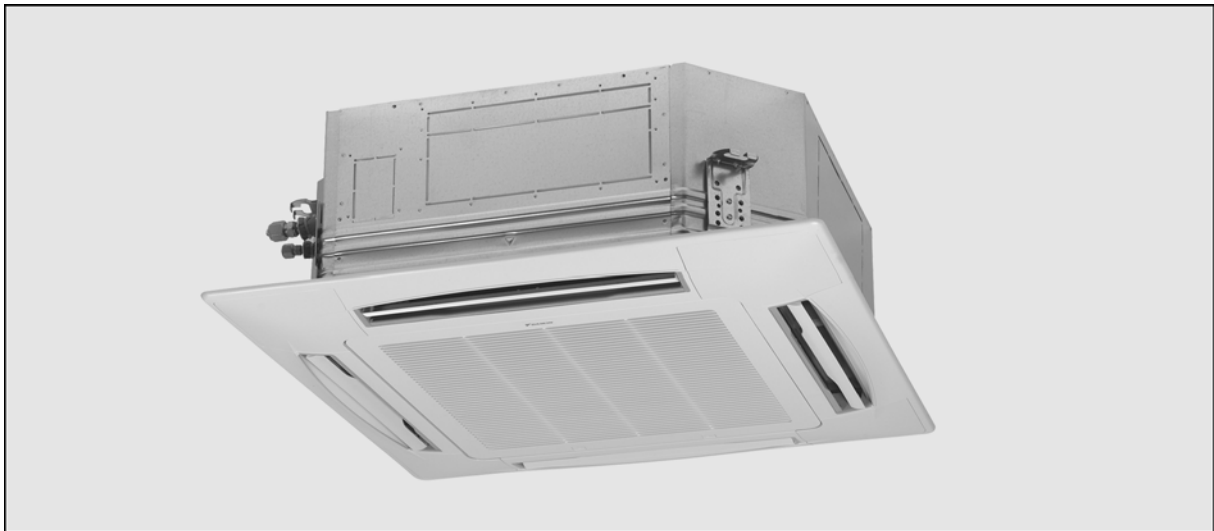

2 Specifications

2-1 NOMINAL CAPACITY AND POWER INPUT						
For indoor units only:						
INDOOR UNITS			FCQ71DV3B	FCQ100DV3B	FCQ125DV3B	FCQ140DV3B
NOMINAL INPUT	Cooling	kW	-	-	-	-
	Heating	kW	-	-	-	-

For combination indoor + outdoor units (air cooled):							
INDOOR UNITS			FCQ71DV3B	FCQ100DV3B	FCQ125DV3B	FCQ140DV3B	
OUTDOOR UNITS			RZQ71B8V3B	RZQ100B8V3B/B7W1B	RZQ125B7W1B	RZQ140B7W1B	
Nominal capacity	Cooling	nominal	kW	3.2~7.1~8.0	5.0~10.0~11.2	5.7~12.5~14.0	6.2~14.0~15.4
	Heating	nominal	kW	3.5~8.0~9.0	5.1~11.2~12.8	6.0~14.0~16.2	6.2~16.0~18.0
Nominal input	Cooling	nominal	kW	1.98	2.44	3.54	4.56
	Heating	nominal	kW	1.97	2.56	3.59	4.52
EER				3.59	4.10	3.53	-
COP				4.06	4.375	3.90	-
Energy label	Cooling			A	A	A	-
	Heating			A	A	A	-
Annual energy consumption	Cooling	kWh		990	1,220	1,770	-

2-2 TECHNICAL SPECIFICATIONS				FCQ71DV3B	FCQ100DV3B	FCQ125DV3B	FCQ140DV3B	
Dimensions	Unit	Height	mm	246	288	288	288	
		Width	mm	840	840	840	840	
		Depth	mm	840	840	840	840	
Weight	Machine Weight	kg		24.0	28.0	28.0	28.0	
Heat Exchanger	Dimensions	Nr of Rows		2	2	2	2	
		Fin Pitch	mm	1.20	1.20	1.20	1.20	
		Face Area	m ²	0.454	0.544	0.544	0.544	
		Nr of Stages		10	12	12	12	
	Tube type	Hi-XSS (7)						
Fin	Type	Cross fin coil (Multi louver fins and Hi-XSS tubes)						
Fan	Type	Turbo fan						
Air Flow Rate	Cooling	High	m ³ /min	19.0	30.0	30.0	30.0	
		Low	m ³ /min	14.0	21.0	24.0	25.0	
	Heating	High	m ³ /min	19.0	30.0	30.0	30.0	
		Low	m ³ /min	14.0	21.0	24.0	25.0	
Fan	Motor	Model		QTS46F15M	QTS46E17M	QTS46E17M	QTS46E17M	
		Output (high)	W	30	120	120	120	
Cooling	Sound Power	High	dBA	50.0	58.0	58.0	58.0	
		Low	dBA	44.0	48.0	51.0	53.0	
	Sound Pressure	High	dBA	34.0	43.0	43.0	43.0	
		Low	dBA	28.0	33.0	36.0	38.0	
Heating	Sound Power	High	dBA	50.0	58.0	58.0	58.0	
		Low	dBA	44.0	48.0	51.0	53.0	
	Sound Pressure	High	dBA	34.0	43.0	43.0	43.0	
		Low	dBA	28.0	33.0	36.0	38.0	
Refrigerant	Type	R-410A						
Piping connections	Liquid (OD)	Type	Flare connection					
		Diameter (OD)	mm	9.5	9.5	9.5	9.5	
	Gas	Type	Flare connection					
		Diameter (OD)	mm	15.9	15.9	15.9	15.9	
	Drain	Diameter (OD)	mm	I.D. 25/O.D. 32				

2-2 TECHNICAL SPECIFICATIONS			FCQ71DV3B	FCQ100DV3B	FCQ125DV3B	FCQ140DV3B	
Decoration Panel	Model		BYCP125DJW1				
	Colour		White				
	Dimensions	H	mm	45	45	45	45
		W	mm	950	950	950	950
		D	mm	950	950	950	950
Weight		kg	5.5	5.5	5.5	5.5	
Air Filter			Resin net with mold resistance				
Safety Devices			—		Low pressure switch		
			High pressure switch				
			Fuse				

2-3 ELECTRICAL SPECIFICATIONS			FCQ71DV3B	FCQ100DV3B	FCQ125DV3B	FCQ140DV3B
Power Supply	Name		V3	V3	V3	V3
	Phase		1	1	1	1
	Frequency	Hz	50	50	50	50
	Voltage	V	230	230	230	230

NOTES

- Nominal cooling capacities are based on : indoor temperature : 27°CDB, 19°CWB, outdoor temperature : 35°CDB, equivalent refrigerant piping : 7.5m, level difference : 0m.
- Nominal heating capacities are based on : indoor temperature : 20°CDB, outdoor temperature : 7°CDB, 6°CWB, equivalent refrigerant piping : 7.5m, level difference : 0m.
- Capacities are net, including a deduction for cooling (an addition for heating) for indoor fan motor heat.
- In case of drain piping for the outdoor unit, a drain piping kit (option) is needed.

3 Options

Item	Model		FCQ71D	FCQ100D	FCQ125D	FCQ140D
Decoration panel			BYCP125DJW1			
Panel spacer			KDBP55H160WA			
Filter related	High efficiency filter 65%	Colorimetric method	KAFP556D80	KAFP556D160		
	High efficiency filter 90%	Colorimetric method	KAFP557D80	KAFP557D160		
	Replacement high efficiency filter 65%	Colorimetric method	KAFP552H80	KAFP552H160		
	Replacement high efficiency filter 90%	Colorimetric method	KAFP553H80	KAFP553H160		
	Filter chamber			KDDFP55D160		
	Long life filter			KAFJ551C160		
	Ultra long-life filter			KAFP55D160		
	Replacement ultra long-life filter			KAFJ55K160H		
Fresh air intake kit	Chamber type	Without T-shape and fan	KDDP55D160			
		With T-shape, without fan	KDDP55D160K			
	Direct installation type		KDDJ55X160			
Branch duct chamber			KDP55D80	KDP55D160		
Insulation kit for high humidity			KDT-55D80	KDT-55D160		
Remote control	Infrared		BRC7E51W			
	Wired		BRC1D527			
Central remote control			DCS302C51			
Unified ON/OFF control			DCS301B51			
Schedule timer			DST301B51			
Adapter for wiring *1			KRP1B59			
Wiring adapter for electrical appendices *1			KRP4A53			
Installation box for adapter PCB			KRP1D98			

*1 Installation box for adapter PCB (KRP1D98) is necessary

3D048828

4 Dimensional drawing

4 - 1 Dimensional drawing

4

FCQ71D

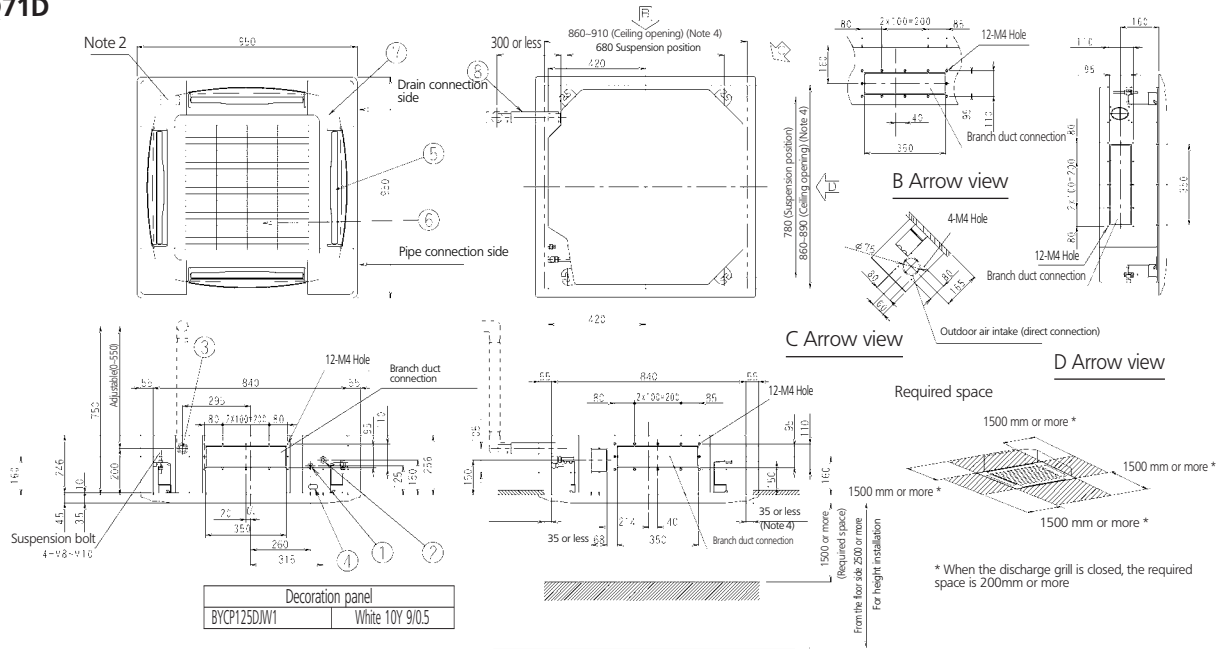

Note:

1. Sticking location for manufacturer's label
 Manufacturer's label for indoor unit: on the bell mouth inside suction grille.
 Manufacturer's label for decoration panel: on the inner frame inside suction grille.
2. In case of using an infrared remote control, this position will be a signal receiver.
 Refer to the drawing of infrared remote control in detail

3. When it may exceed 30°C and RH 80% in the ceiling or fresh air is inducted into the ceiling, an additional insulation (Thickness 10mm or more of glasswool or polyethylene form) is required.
4. Though the installation is acceptable up to maximum of 910mm square ceiling opening, keep the clearance of 35mm or less between the main unit and the ceiling opening so that the panel overlap allowance can be ensured.

- 1 Liquid pipe connection ϕ 9.5 Flare connection
 - 2 Gas pipe connection ϕ 15.9 Flare connection
 - 3 Drain pipe connection VP25 (O.D. ϕ 32)
 - 4 Power supply connection / wiring / remote control connection
 - 5 Air outlet
 - 6 Air suction grille
 - 7 Corner decoration cover
 - 8 Drain hose (option) O.D. ϕ 32 (outlet)
- 3D033593A

FCQ100~140D

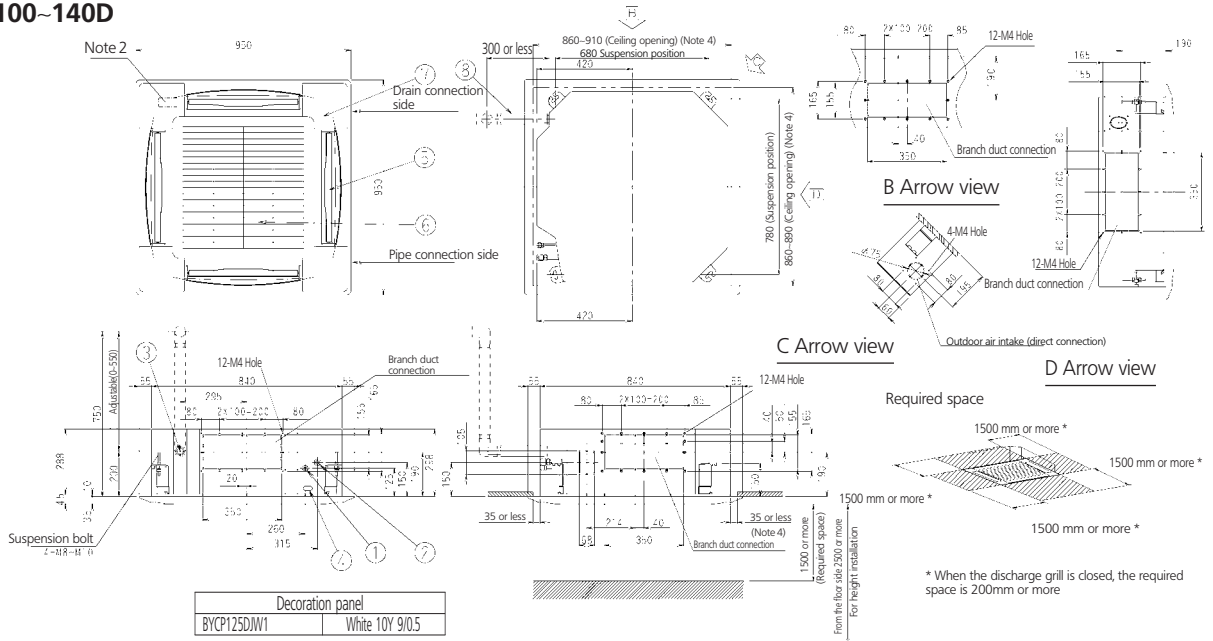

Note:

1. Sticking location for manufacturer's label
 Manufacturer's label for indoor unit: on the bell mouth inside suction grille.
 Manufacturer's label for decoration panel: on the inner frame inside suction grille.
2. In case of using an infrared remote control, this position will be a signal receiver.
 Refer to the drawing of infrared remote control in detail

3. When it may exceed 30°C and RH 80% in the ceiling or fresh air is inducted into the ceiling, an additional insulation (Thickness 10mm or more of glasswool or polyethylene form) is required.
4. Though the installation is acceptable up to maximum of 910mm square ceiling opening, keep the clearance of 35mm or less between the main unit and the ceiling opening so that the panel overlap allowance can be ensured.

- 1 Liquid pipe connection ϕ 9.5 Flare connection
 - 2 Gas pipe connection ϕ 15.9 Flare connection
 - 3 Drain pipe connection VP25 (O.D. ϕ 32)
 - 4 Power supply connection / wiring / remote control connection
 - 5 Air outlet
 - 6 Air suction grille
 - 7 Corner decoration cover
 - 8 Drain hose (option) O.D. ϕ 32 (outlet)
- 3D048825

5 Piping diagram

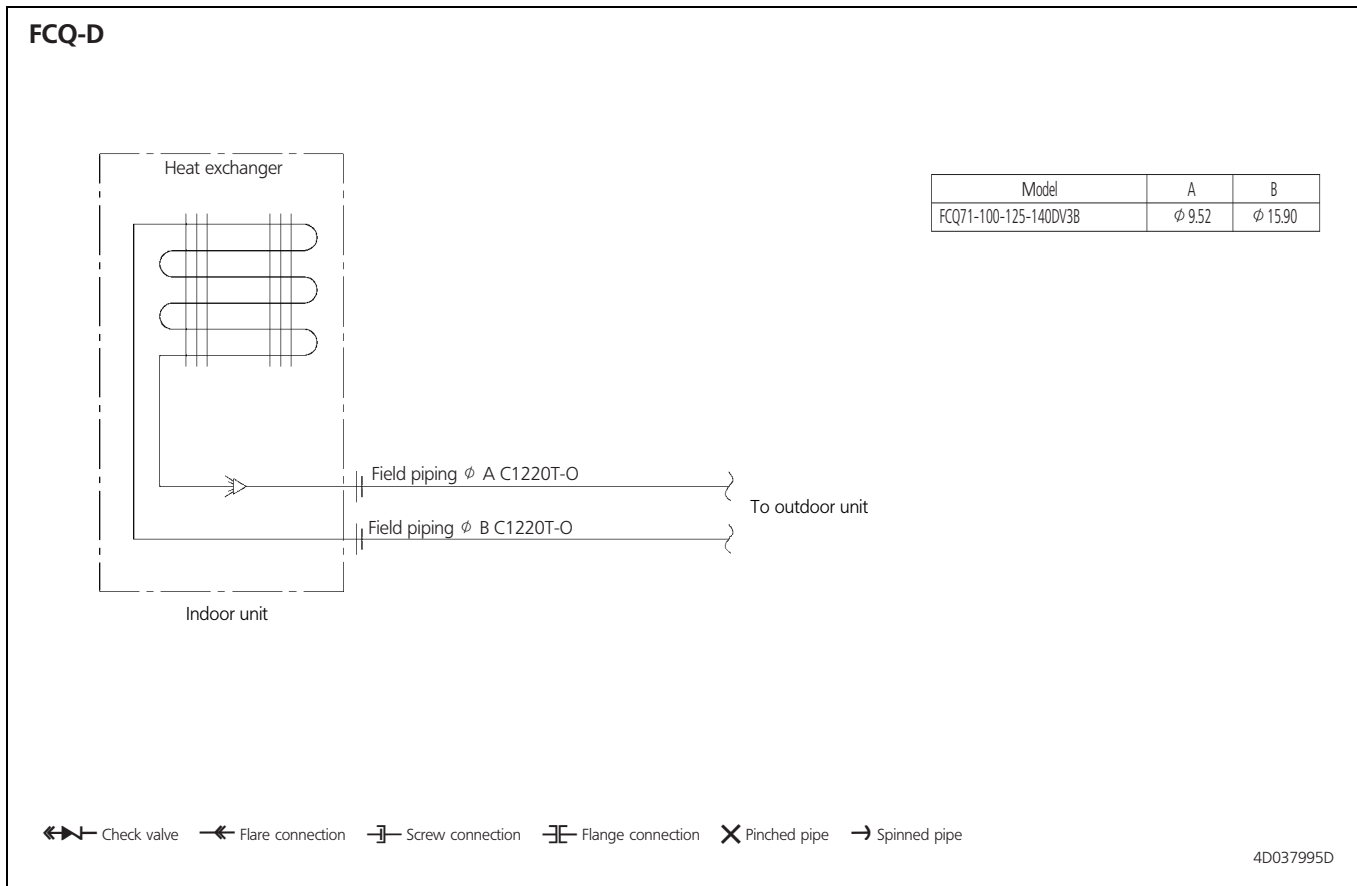

6 Wiring diagram

6 - 1 Wiring diagram

6

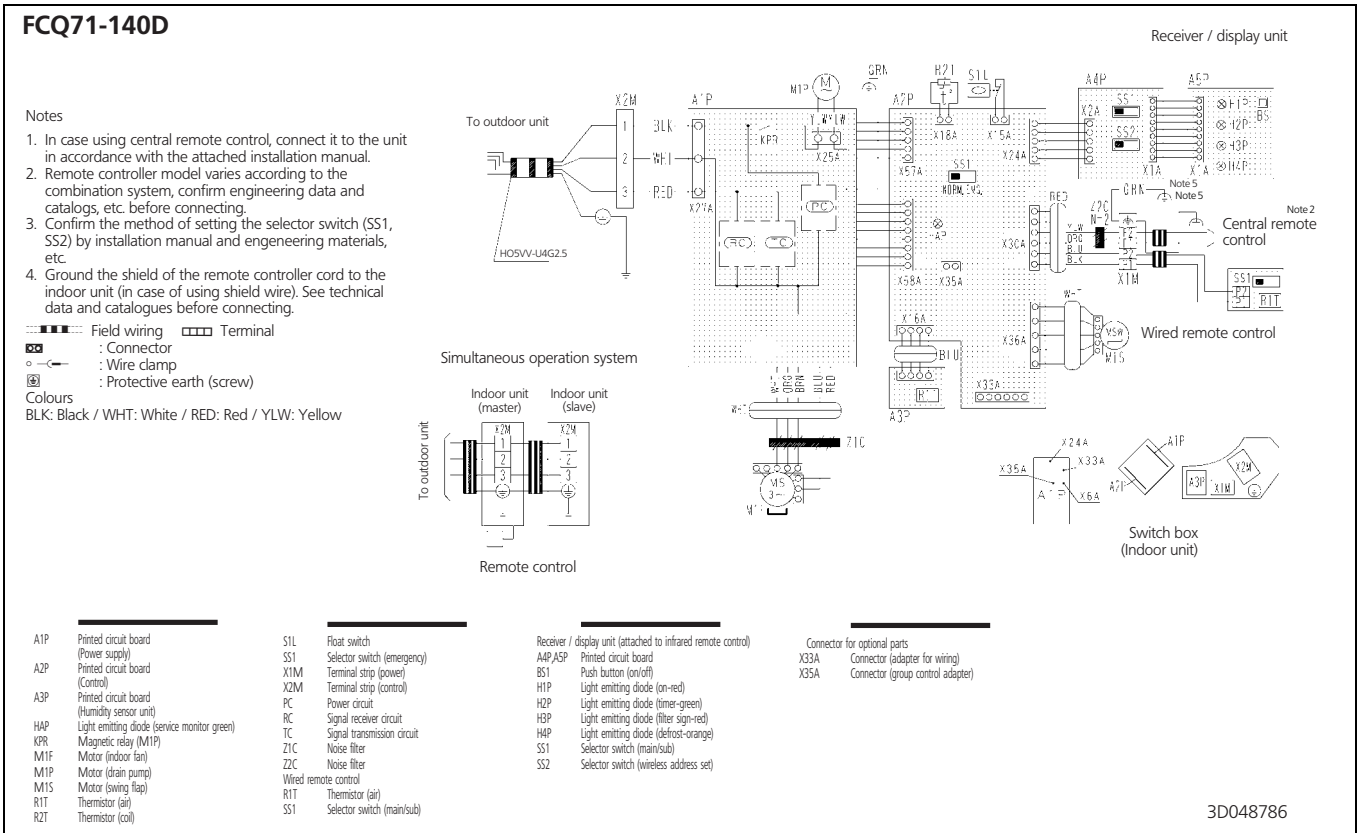

6 - 2 External connection diagram

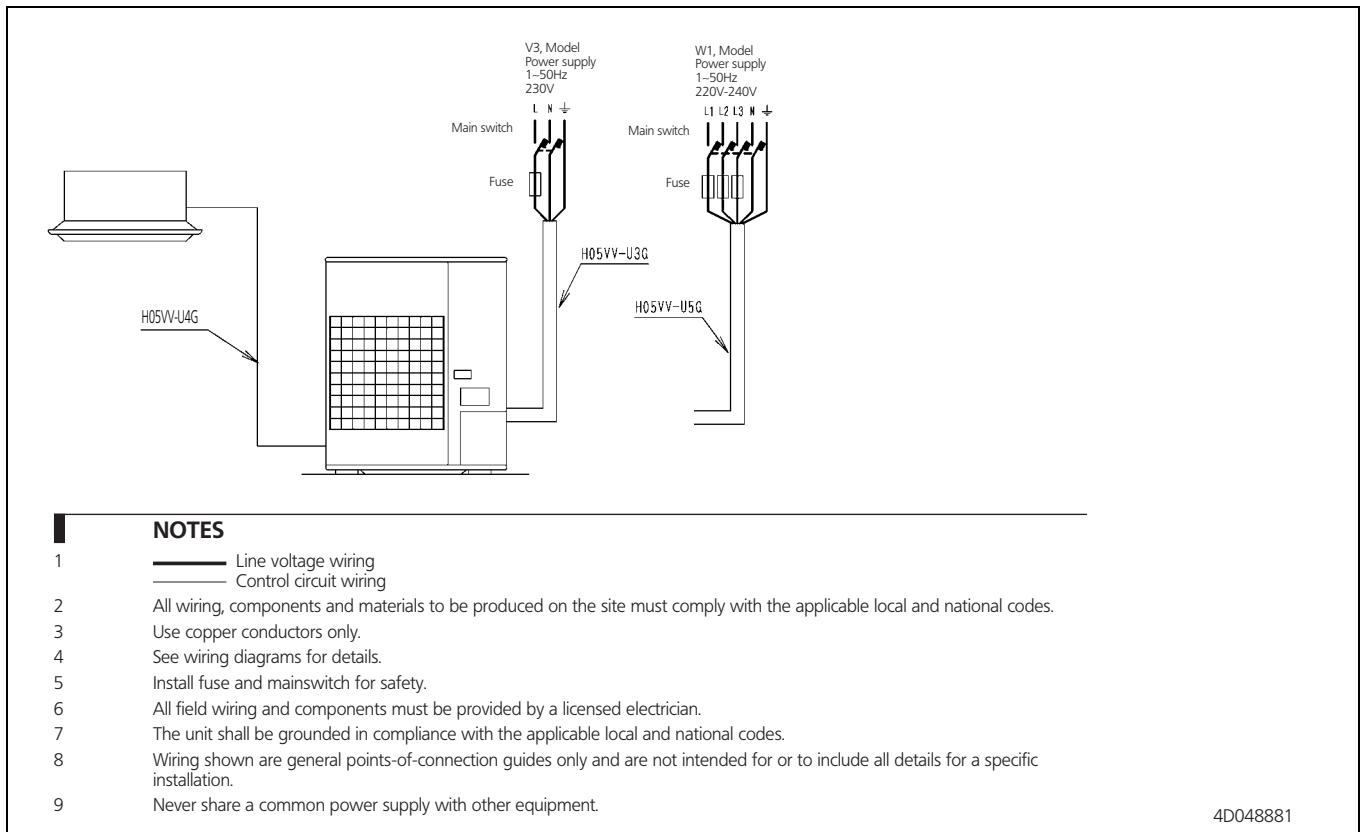

8

7 Sound data

7 - 1 Sound pressure spectrum

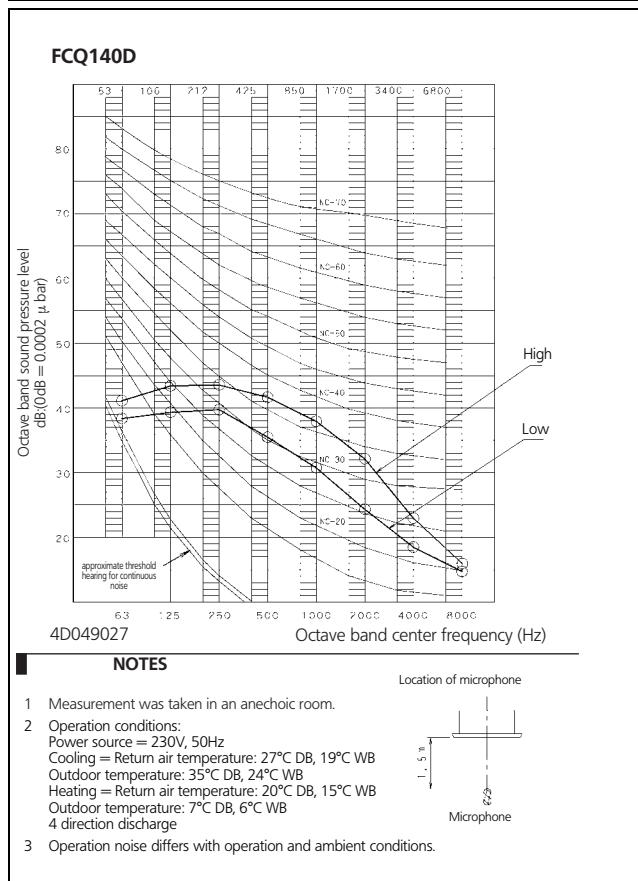
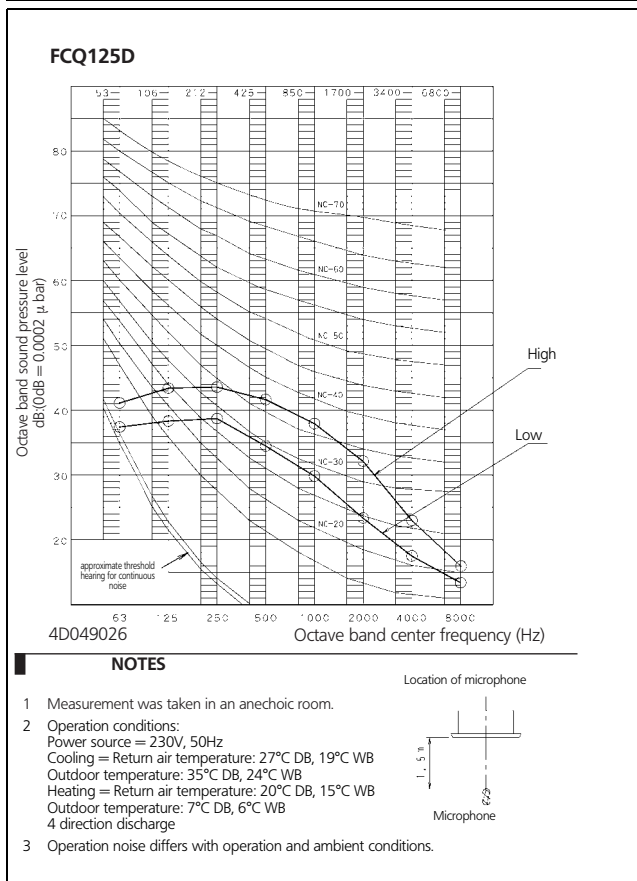
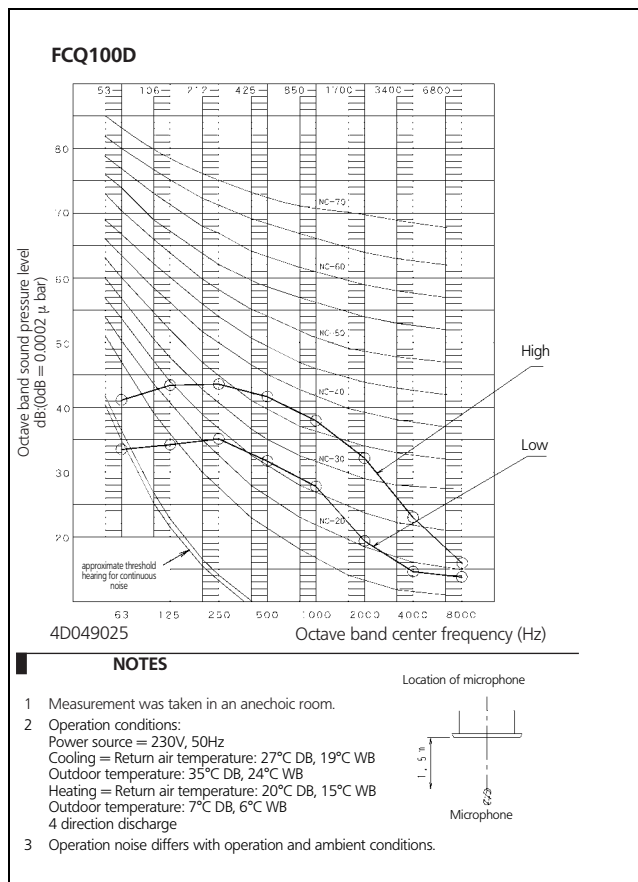
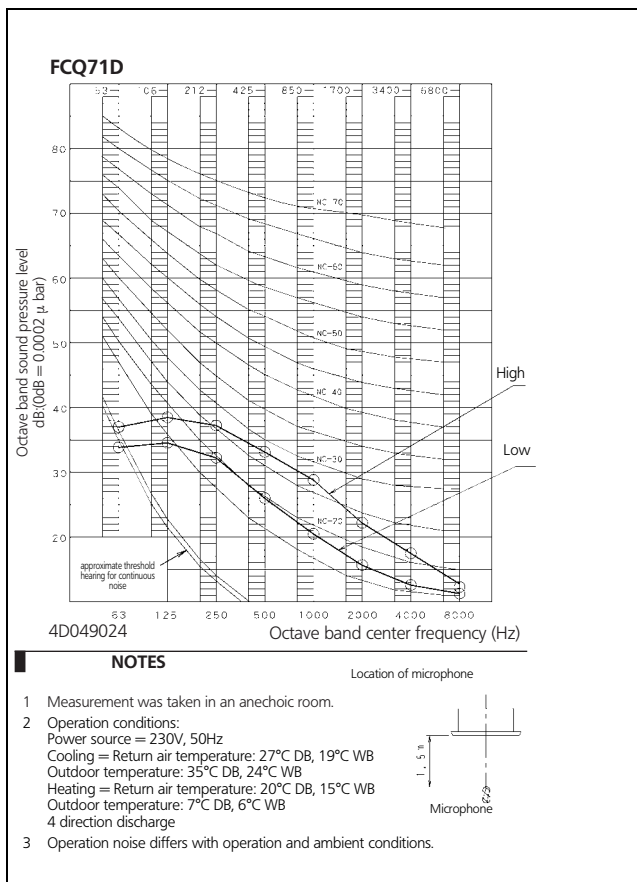

8 Air flow pattern

8 FCQ71D

Cooling - air velocity distribution

4-way discharge air flow direction: horizontal

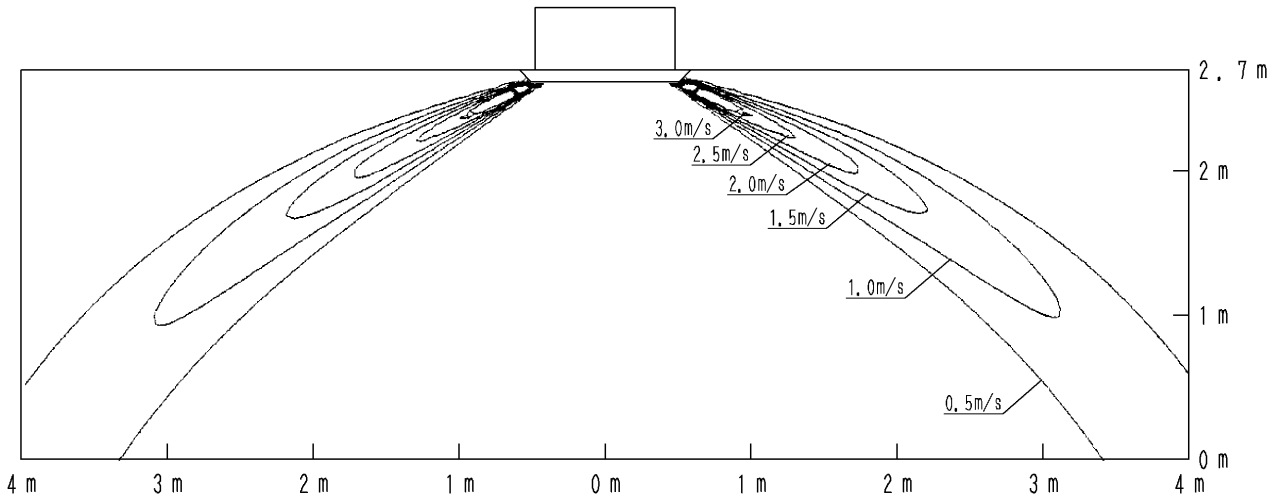

FCQ71D

Cooling - air temperature distribution

4-way discharge air flow direction: horizontal

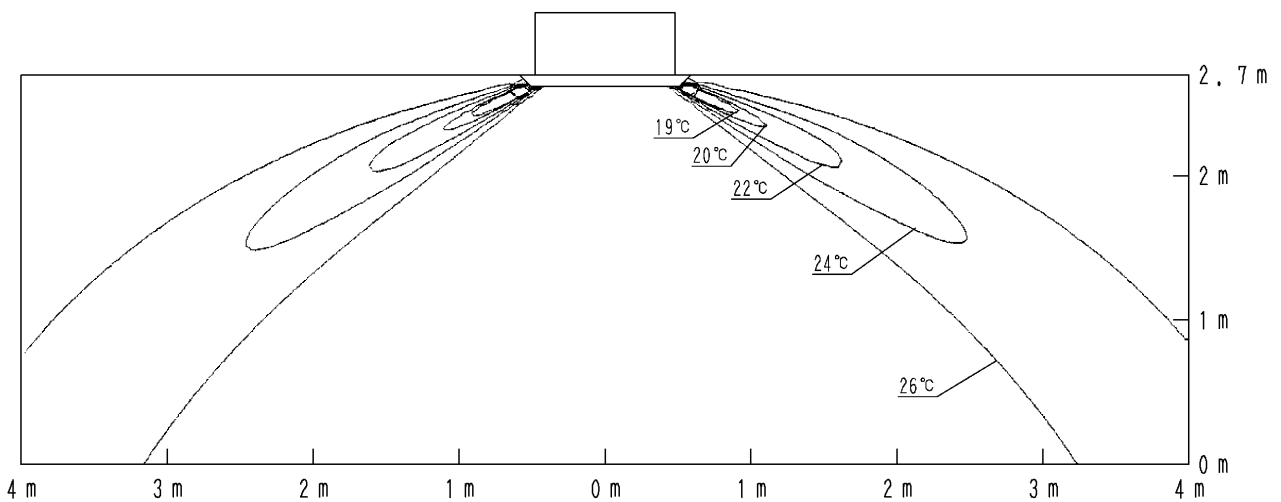

4D049080

8 Air flow pattern

FCQ100D

Cooling - air velocity distribution

4-way discharge air flow direction: horizontal

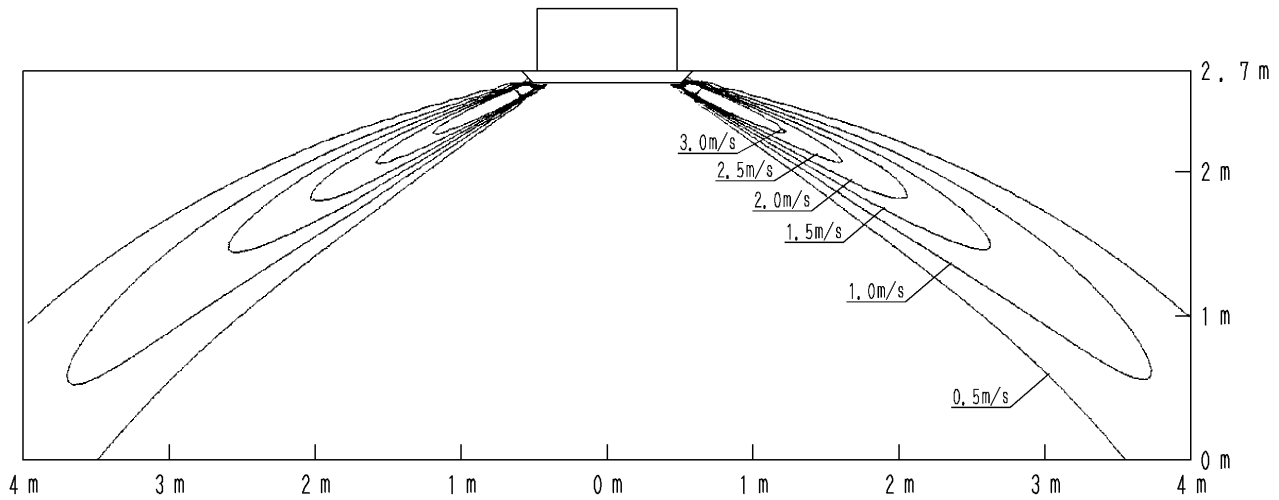

FCQ100D

Cooling - air temperature distribution

4-way discharge air flow direction: horizontal

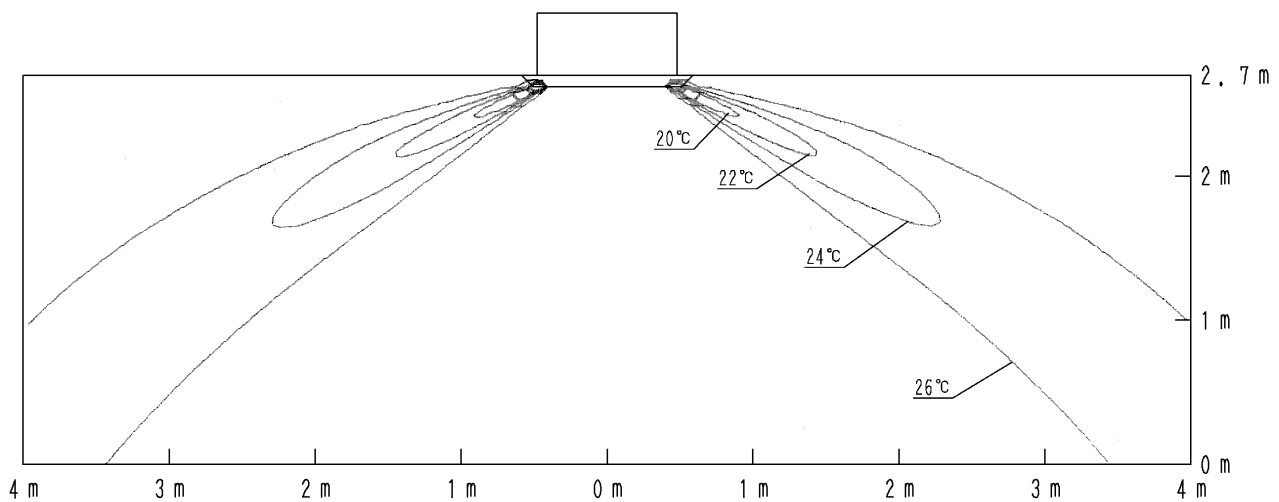

4D049084

8 Air flow pattern

8

FCQ125D

Cooling - air velocity distribution

4-way discharge air flow direction: horizontal

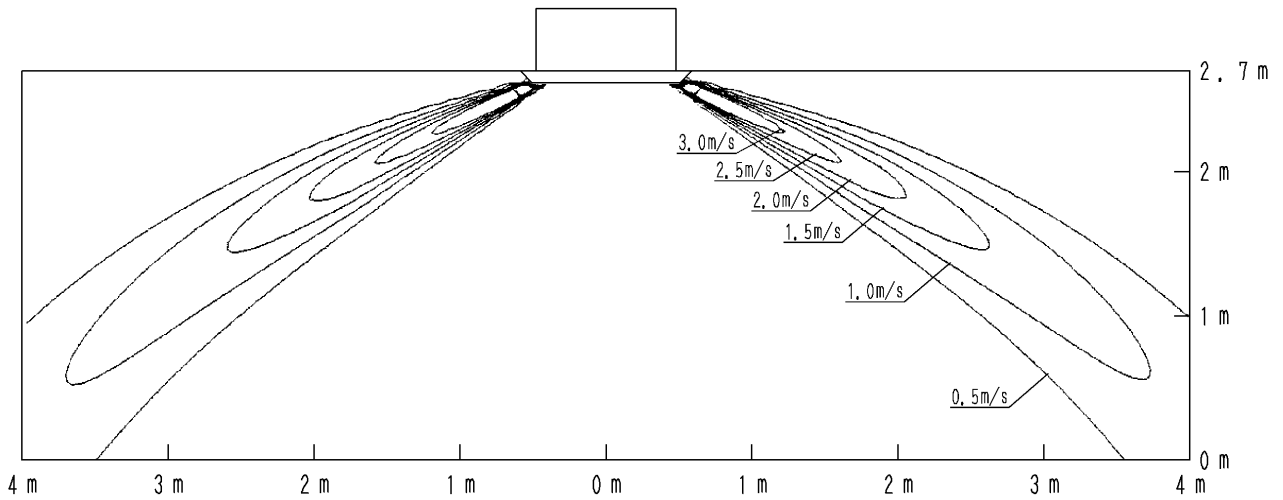

FCQ125D

Cooling - air temperature distribution

4-way discharge air flow direction: horizontal

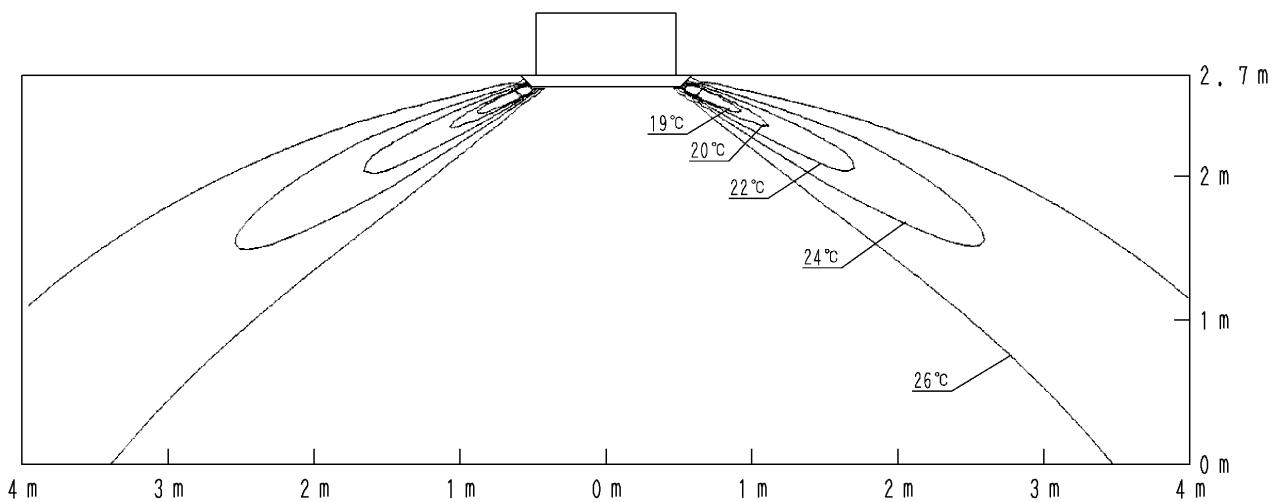

4D049082

8 Air flow pattern

FCQ140D

Cooling - air velocity distribution

4-way discharge air flow direction: horizontal

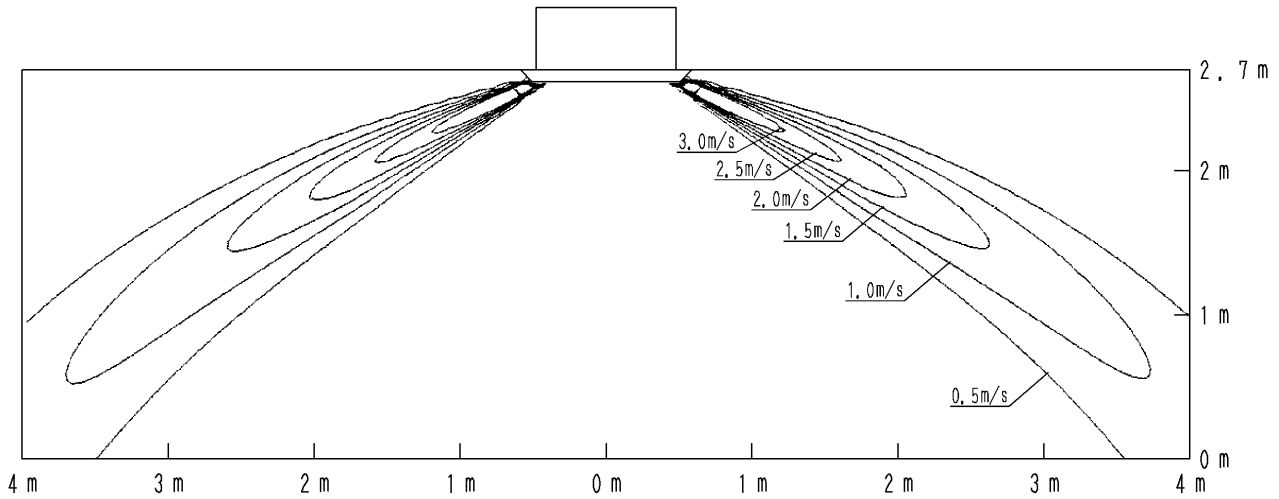

FCQ140D

Cooling - air temperature distribution

4-way discharge air flow direction: horizontal

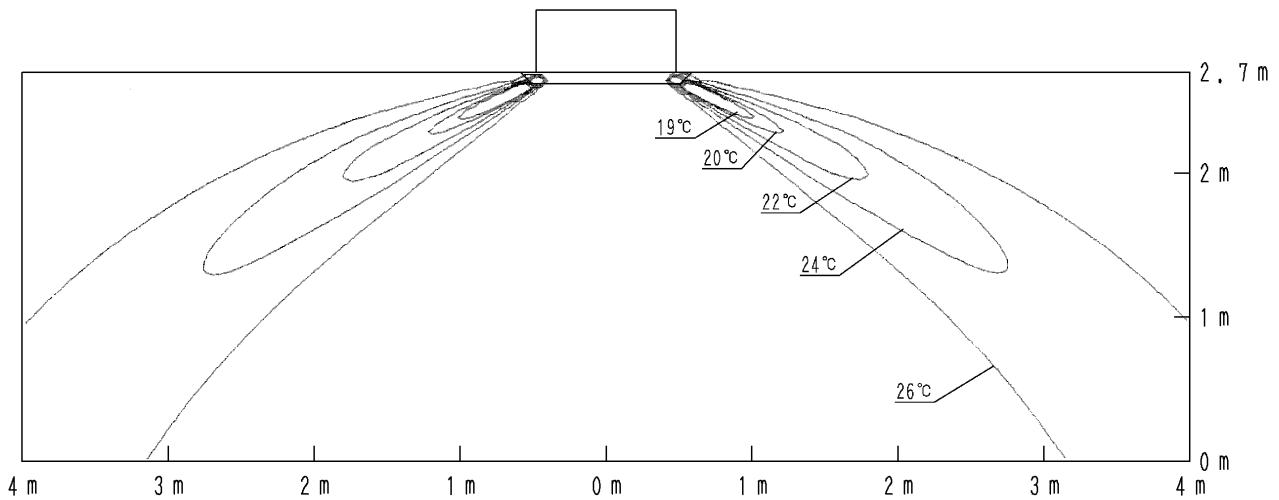

4D049086

8 Air flow pattern

8

FCQ71D

Heating - air velocity distribution

4-way discharge, air flow direction: down

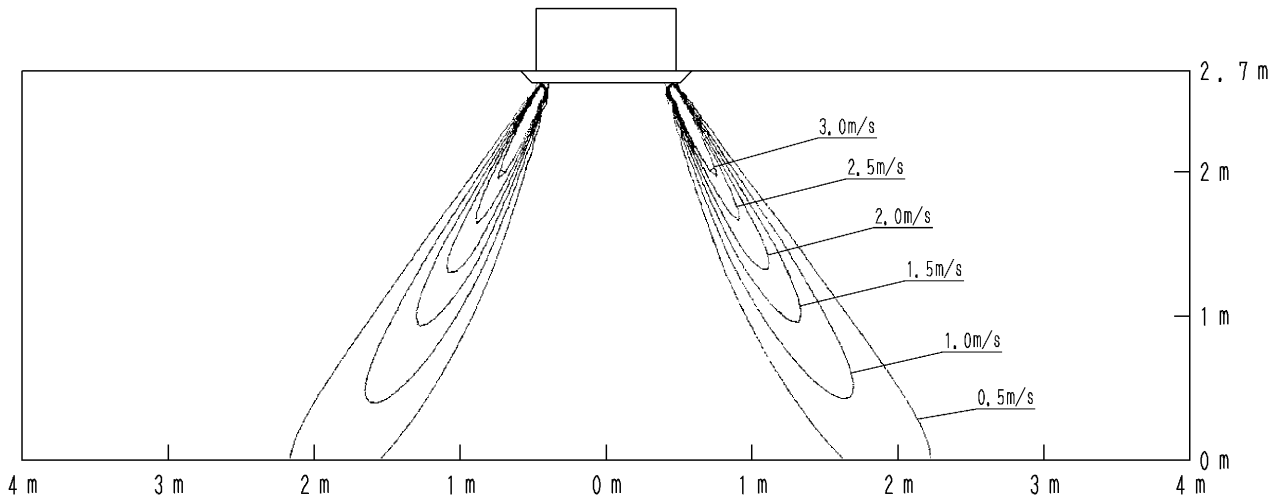

FCQ71D

Heating - air temperature distribution

4-way discharge, air flow direction: down

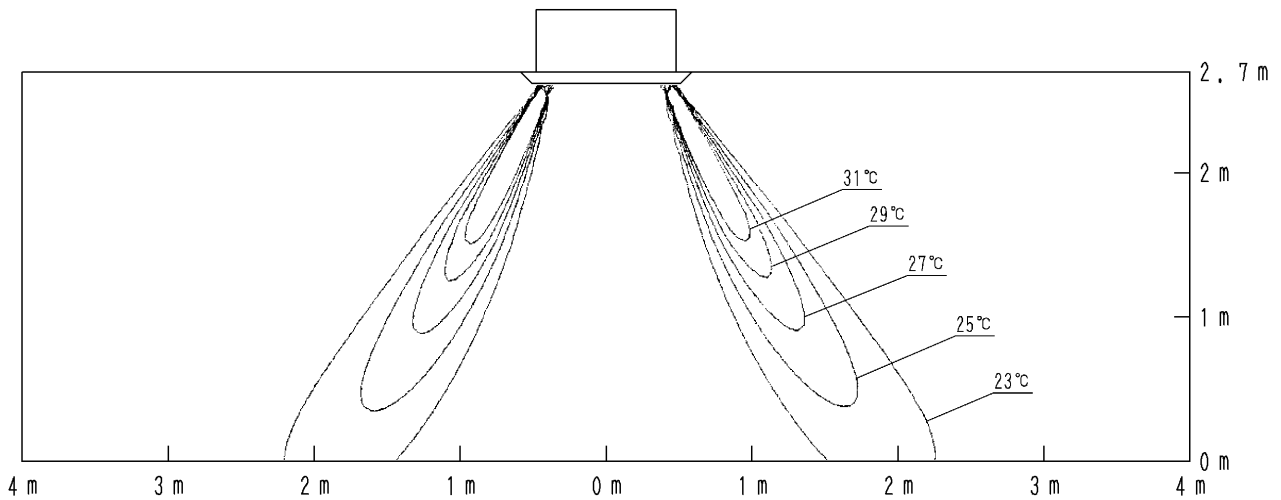

4D049081

8 Air flow pattern

FCQ100D

Heating - air velocity distribution

4-way discharge, air flow direction: down

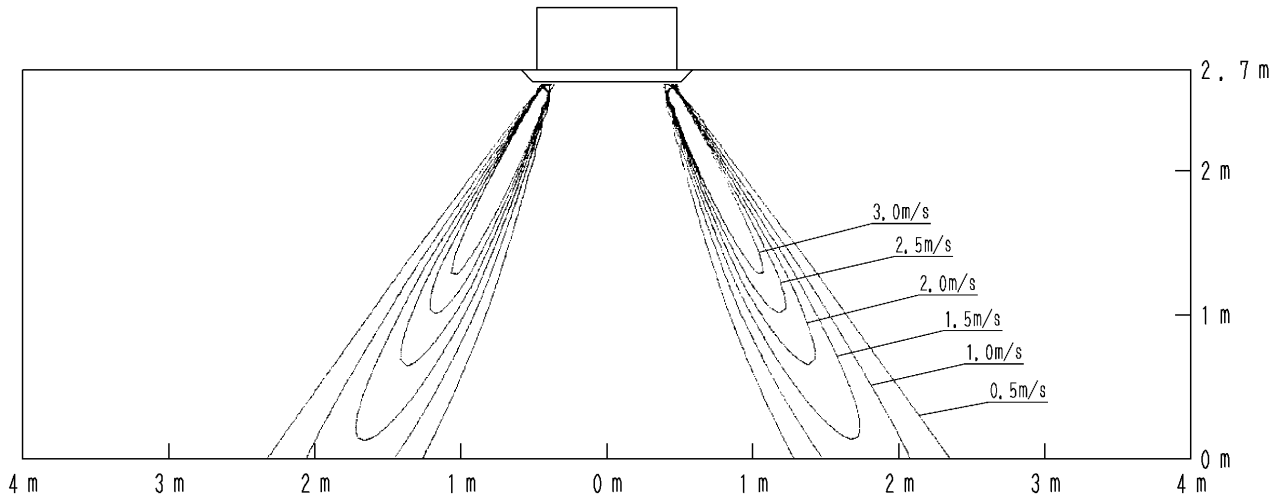

FCQ100D

Heating - air temperature distribution

4-way discharge, air flow direction: down

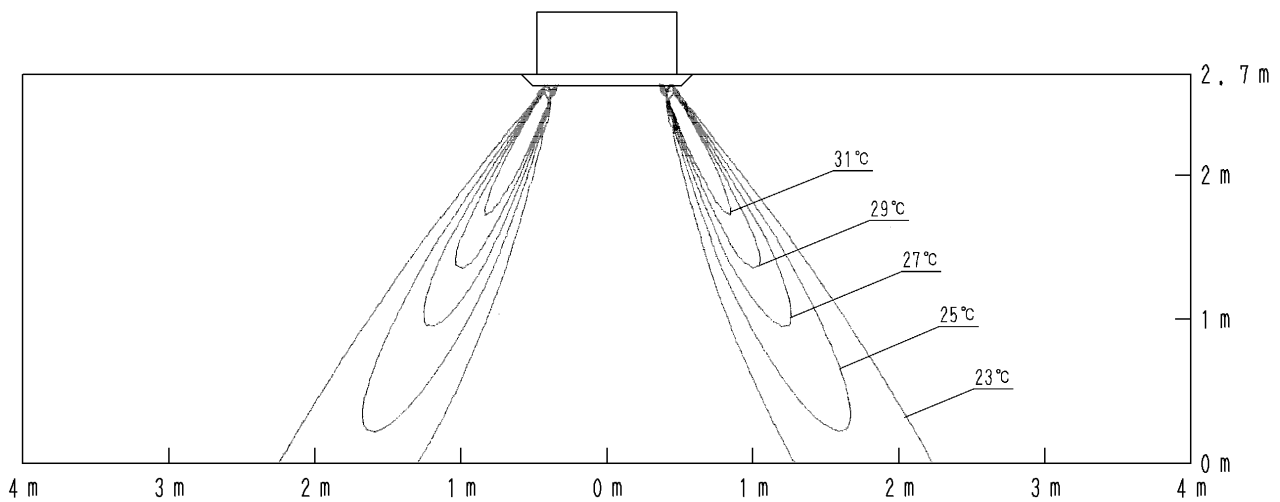

4D049085

8 Air flow pattern

8

FCQ125D

Heating - air velocity distribution

4-way discharge, air flow direction: down

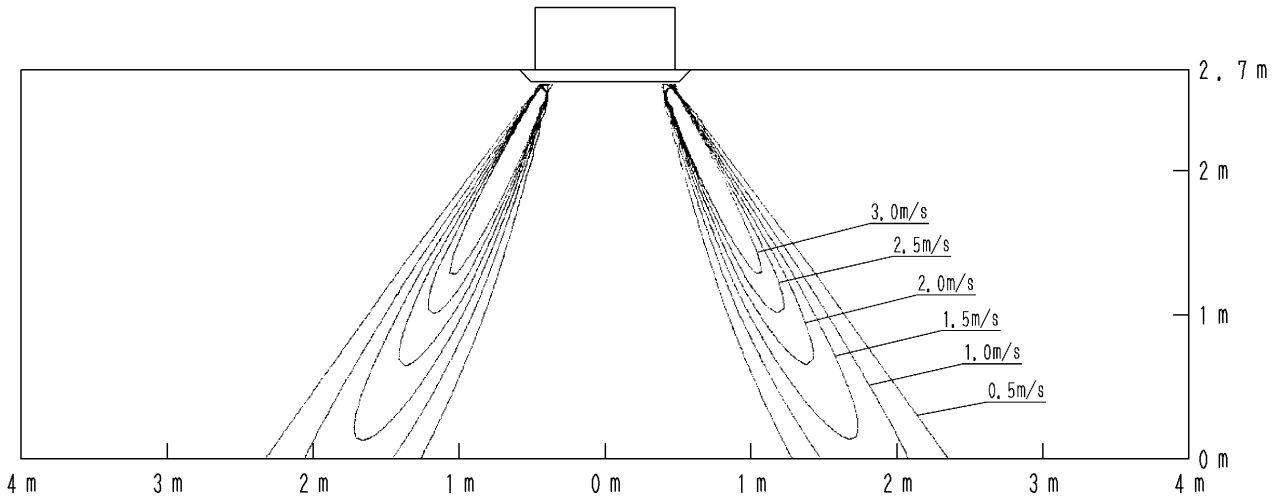

FCQ125D

Heating - air temperature distribution

4-way discharge, air flow direction: down

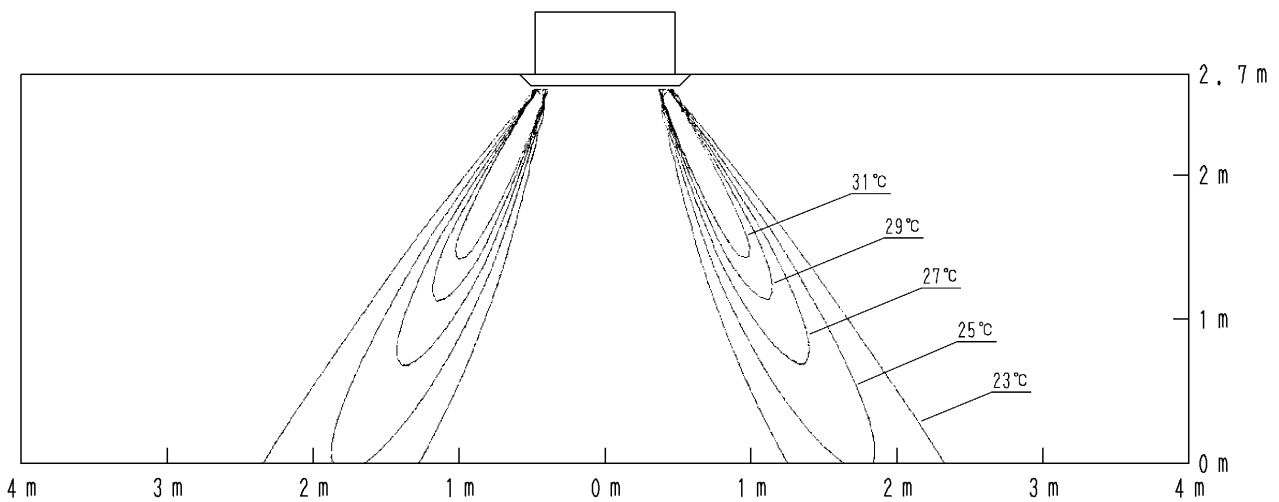

4D049083

8 Air flow pattern

FCQ140D

Heating - air velocity distribution

4-way discharge, air flow direction: down

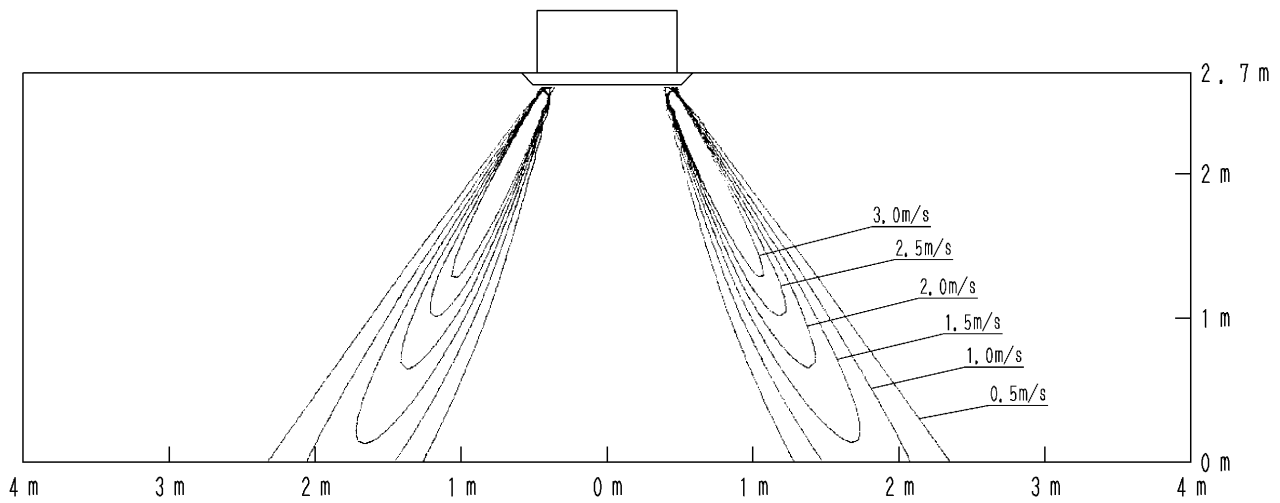

FCQ140D

Heating - air temperature distribution

4-way discharge, air flow direction: down

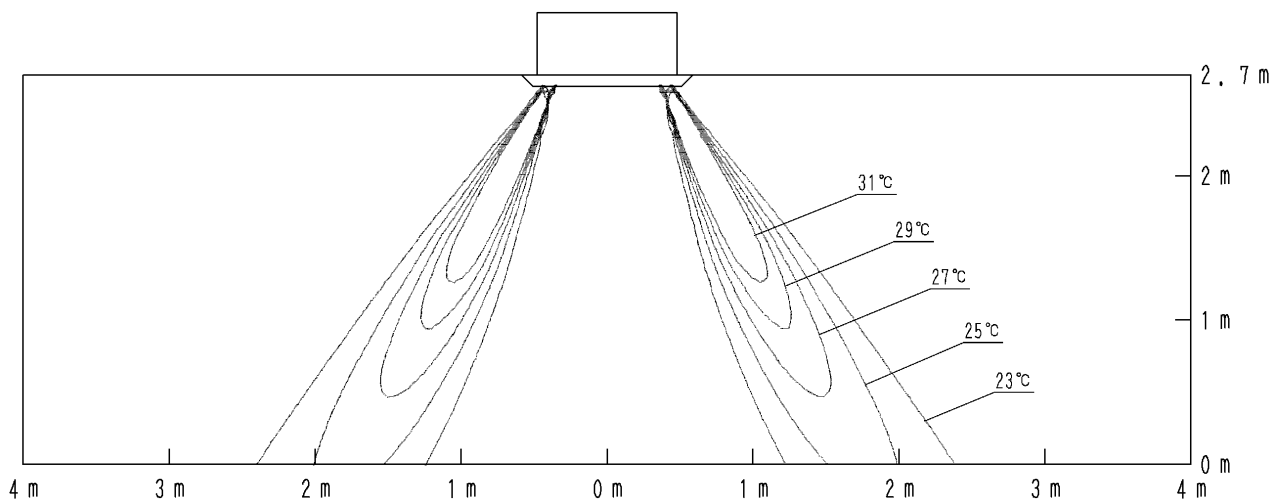

4D049087