















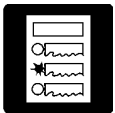

1 Features

- Improved operating efficiency
- Modern style decoration panel in white (RAL9010)
- 360° air discharge ensures uniform air flow and temperature distribution
- Air discharge from the corners avoids dead zones that may be subject to temperature differences
- Comfortable horizontal air discharge ensures draughtfree operation and prevents ceiling soiling
- 23 different air flow patterns possible
- Fresh air intake: up to 20 %
- Easy visible drain check thanks to clear drain socket
- Drain-up pump with 850mm lift fitted as standard



30
1

								
	heat pump			optional			2 steps	
								
optional						optional		

2 Specifications

2-1 TECHNICAL SPECIFICATIONS				FCQH71C7VEB	FCQH100C7VEB	FCQH125C7VEB	FCQH140C7VEB
Casing	Material			Galvanised steel plate			
Dimensions	Packing	Height	mm	262	304	304	304
		Width	mm	882	882	882	882
		Depth	mm	882	882	882	882
	Unit	Height	mm	246	288	288	288
		Width	mm	840	840	840	840
Depth		mm	840	840	840	840	
Weight	Unit		kg	23	25	25	25
	Packed Unit		kg	28	30	30	30
Heat Exchanger	Dimensions	Length	mm	inside: 2096, outside: 2152			
		Nr of Rows		2	2	2	2
		Fin Pitch	mm	1.2	1.2	1.2	1.2
		Nr of Passes		5	11	11	11
		Face Area	m ²	0.446	0.535	0.535	0.535
	Nr of Stages		10	12	12	12	
Fin	Type			Cross fin coil (Multi louver fins and Hi-XSS tubes)			
Fan	Type			Turbo fan			
	Quantity			1	1	1	1
Air Flow Rate	Cooling	High	m ³ /min	20.0	32.5	32.5	32.5
		Low	m ³ /min	12.0	18.0	21.5	21.5
	Heating	High	m ³ /min	20.0	32.5	32.5	32.5
		Low	m ³ /min	12.0	18.0	21.5	21.5
Fan	Motor	Model		QTS48C15M			
		Number of steps		2	2	2	2
		Output (high)	W	120	120	120	120
Cooling	Sound Power	High	dBA	52	60	60	60
		Low	dBA	28	32	36	38
	Sound Pressure	High	dBA	34	43	43	43
Heating	Sound Pressure	High	dBA	34	43	43	43
		Low	dBA	28	32	36	38
Sound Level	Sound Absorbing Insulation			foamed polyurethane			
Refrigerant	Type			R-410A			
Piping connections	Liquid (OD)	Type		Flare connection			
		Diameter (OD)	mm	9.5	9.5	9.5	9.5
	Gas	Type		Flare connection			
		Diameter (OD)	mm	15.9	15.9	15.9	15.9
	Drain	Diameter (OD)		VP25 (I.D. 25/O.D. 32)			
Heat Insulation			Foamed polystyrene/polyethylene				
Decoration Panel	Model			BYCQ140CW1			
	Colour			Pure White(RAL 9010)			
	Dimensions	H	mm	50	50	50	50
		W	mm	950	950	950	950
		D	mm	950	950	950	950
Weight		kg	5.5	5.5	5.5	5.5	
Air Filter	Resin net with mold resistance						

2 Specifications

2-1 TECHNICAL SPECIFICATIONS		FCQH71C7VEB	FCQH100C7VEB	FCQH125C7VEB	FCQH140C7VEB
Standard Accessories	Item	Installation and operation manual			
		Drain hose			
		Clamp for drain hose			
		Washer for hanger bracket			
		Screws			
		Installation guide			
		Insulation for fitting			
		Sealing pad			
		Drain sealing pad			

3 Safety device settings

FCQH71-140C

Safety devices			71	100	125	140
FCQH	PC board fuse		250V 5A	250V 5A	250V 5A	250V 5A
	Fan motor thermal fuse	°C	---	---	---	---
	Fan motor thermal protector	°C	Off: 108 \pm 5 (On: 96 \pm 15)	Off: 108 \pm 5 (On: 96 \pm 15)	Off: 108 \pm 5 (On: 96 \pm 15)	Off: 108 \pm 5 (On: 96 \pm 15)
	Drain pump fuse	°C	145	145	145	145

3TW28921-3

4 Options

FCQH71-140C

OPTIONS

No.	Item	Model	FCQH71	FCQH100	FCQH125	FCQH140
1	Decoration panel			BYCQ140CW1		
2	Long life replacement filter	non-woven type		KAFP551K160		
3	Fresh air intake kit (20% fresh air)	Chamber type		KDDQ55C140		
4	Sealing member of air discharge outlet			KDBHQ55C140		

CONTROL SYSTEM

No.	Item	Model	FCQH71	FCQH100	FCQH125	FCQH140
1	Remote control	Wireless	H/P	BRC7F532F		
			C/O	BRC7F533F		
		Wired		BRC1D528		
2-1	Wiring adapter for electrical appendices (1)		KRP1BA57 *1			
2-2	Wiring adapter for electrical appendices (2)		KRP4AA53 *1			
2-3	Wiring adapter (hour meter)		EKRP1C11 *1			
3	Remote sensor		KRCS01-4			
4	Installation box for adapter PCB		KRP1H98			
5	Central remote control		DCS302CA51			
6	Unified On/Off control		DCS301BA51			
7	Electrical box with earth terminal (2 blocks)		KJB212AA			
8	Schedule timer		DST301BA51			
9	Remote on/off		EKRORO2			

*1 Installation box is necessary for these adapters.

*2 All options are supplied as kit.

3TW28929-1A

30

4

FCQH71-140C

Max fresh air intake volume table

The maximum intake air flow volume is following table.
If the intake air flow volume is too large, the operating sound may rise or detection of the indoor unit suction temperature may be affected.

FCQH~C7VEB	71	100	125	140
Max fresh air intake volume (m ³ /min)	4.0	4.3	4.3	4.3

The rise of operating sound at with fresh air intake kit

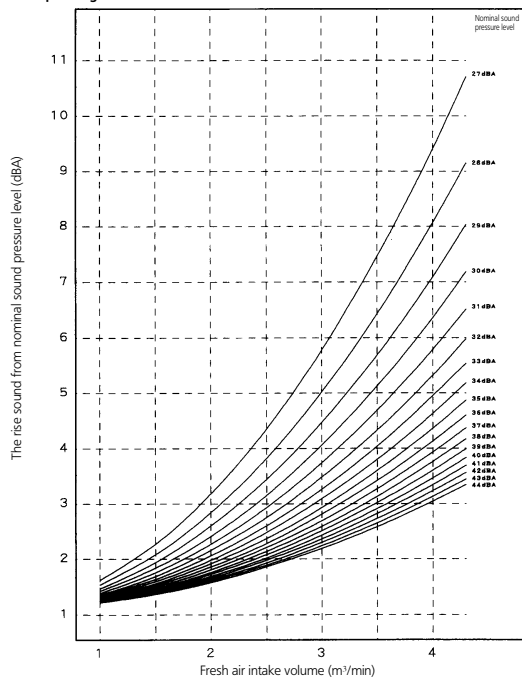

5 Dimensional drawing & centre of gravity

5 - 1 Dimensional drawing

FCQH71C

ANr	Name	Description
1	Liquid pipe connection	ø 9.52 flare connection
2	Gas pipe connection	ø 15.90 flare connection
3	Drain pipe connection	VP25 (O.D. ø32, I.D. ø25)
4	Power supply connection	
5	Transmission wiring connection	
6	Air discharge opening	
7	Air suction grill	
8	Corner decoration cover	
9	Drain house	O.D. ø32 I.D. ø26

NOTES

- Location of the nameplates:
- Unit body: on the control box cover.
- Decoration panel: on the panel frame at the motor side under the cover
- When installing an optional accessory, refer to the installation
- For the fresh air intake kit ... an inspection port is necessary
- In case of using an Infrared remote control, this position will be a signal receiver. Refer to the drawing of the infrared remote control for more detail
- Make sure the spacing between the ceiling and the cassette is no more than 35 mm. Max ceiling opening: 910 mm.
- When the conditions exceed 30°C and RH 80% in the ceiling or fresh air is inducted, into the ceiling, an additional insulation is required (polyethylene foam, thickness 10 mm or more.)

(*) In case a discharge opening is closed with the 'sealing member' option, the distance of 1500 mm can be reduced to 500 mm on the closed side.

3TW28894-1A

30
5

FCQH100,125,140C

ANr	Name	Description
1	Liquid pipe connection	ø9.52 flare connection
2	Gas pipe connection	ø15.90 flare connection
3	Drain pipe connection	VP25 (O.D. ø32, I.D. ø25)
4	Power supply connection	
5	Transmission wiring connection	
6	Air discharge opening	
7	Air suction grill	
8	Corner decoration cover	
9	Drain house	O.D. ø32 I.D. ø26

NOTES

- Location of the nameplates:
- Unit body: on the control box cover.
- Decoration panel: on the panel frame at the motor side under the corner cover
- When installing an optional accessory, refer to the installation drawings
- For the fresh air intake kit ... an inspection port is necessary
- In case of using an Infrared remote control, this position will be a signal receiver. Refer to the drawing of the infrared remote control for more detail
- Make sure the spacing between the ceiling and the cassette is no more than 35 mm. Max ceiling opening: 910 mm.
- When the conditions exceed 30°C and RH 80% in the ceiling or fresh air is inducted into the ceiling, an additional insulation is required (polyethylene foam, thickness 10 mm or more.)
- Please respect the distances as shown on figure above

(*) In case a discharge opening is closed with the 'sealing member' option, the distance of 1500 mm can be reduced to 500 mm on the closed side.

3TW28914-1A

5 Dimensional drawing & centre of gravity

5 - 1 Dimensional drawing

FCQH71C

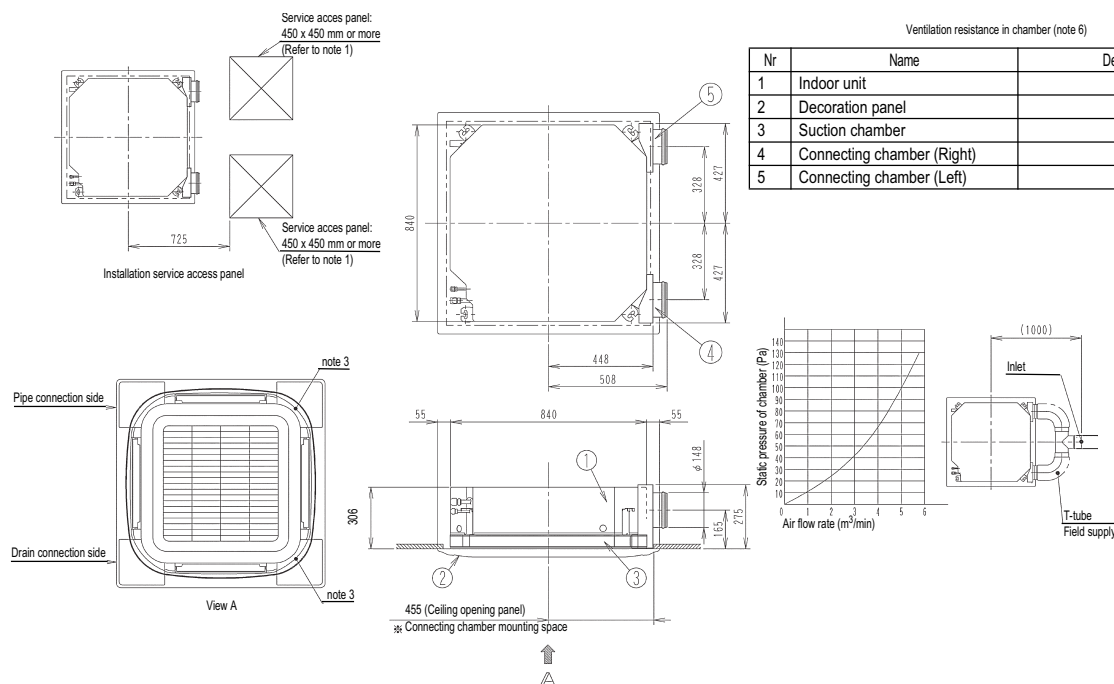

NOTES

- When installing this kit, inspection hatch is necessary. (It is necessary when servicing.) Either one of inspection hatches must be installed.
- Field construction.
- The corner air outlet of this part must be shut.
- In case of mounting a duct fan, make sure to use a wiring adapter for electrical appendices and link with the indoor unit fan.

(*) In case a discharge opening is closed with the 'sealing member' option, the distance of 1500 mm can be reduced to 500 mm on the closed side.

- The intake air flow rate is recommended to be 20% or less of the H speed air flow rate. If the intake air flow rate is too large, the operating sound may rise or detection of the indoor unit suction temperature may be affected.
- It indicates the distance between the T-tube inlet and the indoor unit inlet when the T-tube is connected.

30

5

3D057034

FCQH100,125,140C

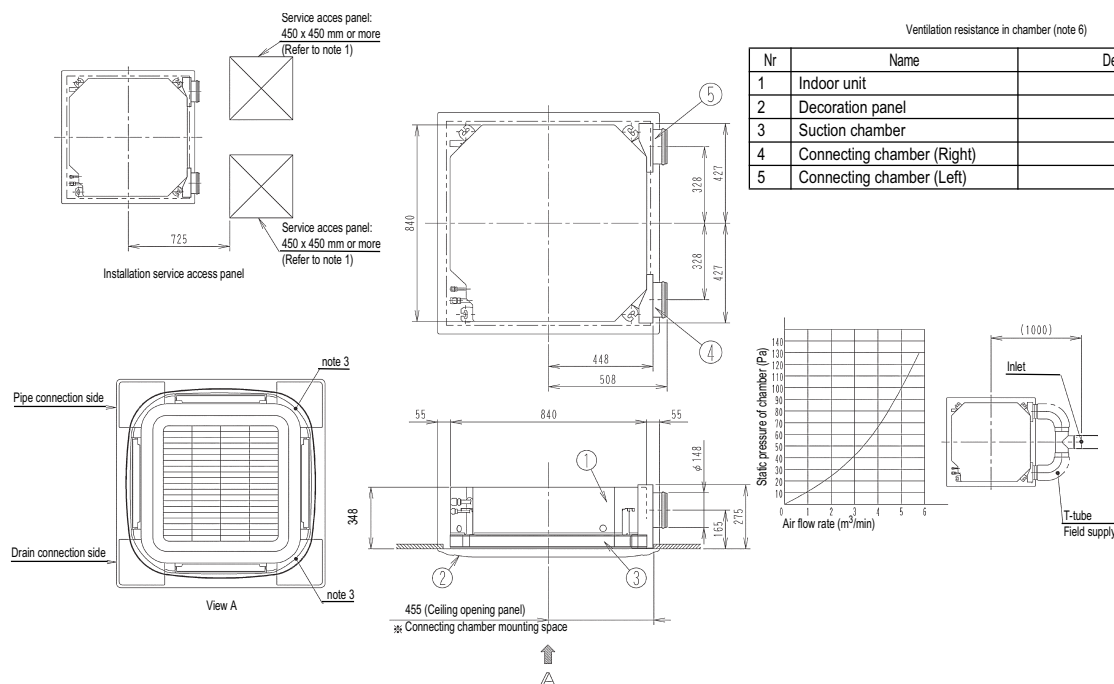

NOTES

- When installing this kit, inspection hatch is necessary. (It is necessary when servicing.) Either one of inspection hatches must be installed.
- Field construction.
- The corner air outlet of this part must be shut.
- In case of mounting a duct fan, make sure to use a wiring adapter for electrical appendices and link with the indoor unit fan.

(*) In case a discharge opening is closed with the 'sealing member' option, the distance of 1500 mm can be reduced to 500 mm on the closed side.

- The intake air flow rate is recommended to be 20% or less of the H speed air flow rate. If the intake air flow rate is too large, the operating sound may rise or detection of the indoor unit suction temperature may be affected.
- It indicates the distance between the T-tube inlet and the indoor unit inlet when the T-tube is connected.

402

3D057032

5 Dimensional drawing & centre of gravity

5 - 1 Dimensional drawing

FCQH71-140C

Remote control dimensions

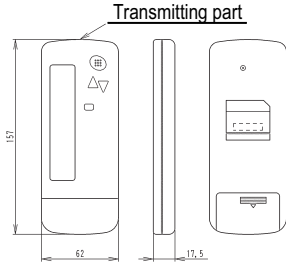

Receiver installation procedure

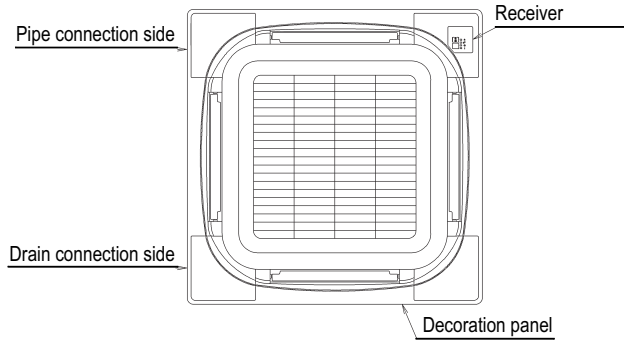

Remote controller holder installation procedure (installation to wall surface)

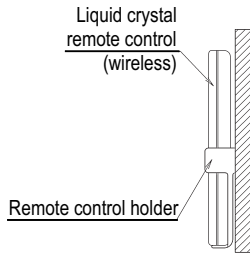

Receiver detail

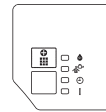

Wireless remote control kit for each decoration panel

Wireless remote control kit	Decoration panel
BRC7F532F BRC7F533F	BYCQ140CW1

3D056851

5 Dimensional drawing & centre of gravity

5 - 2 Centre of gravity

FCQH71-140C

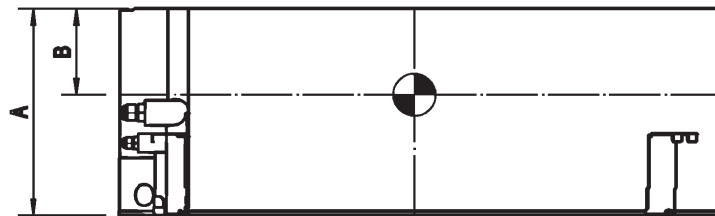
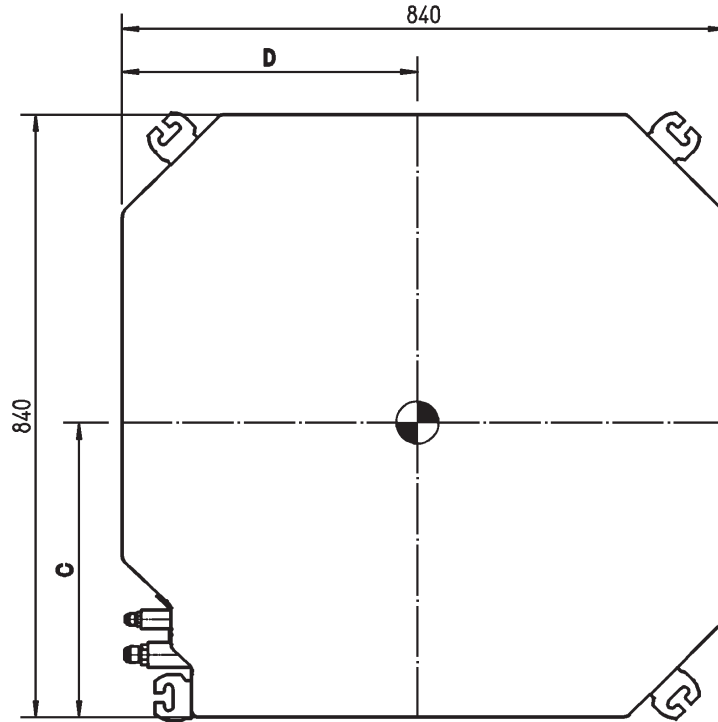

Models	A	B	C	D
FCQH71	246	90	411	411
FCQH100~140	288	120	420	420

4TW28839-2

6 Piping diagram

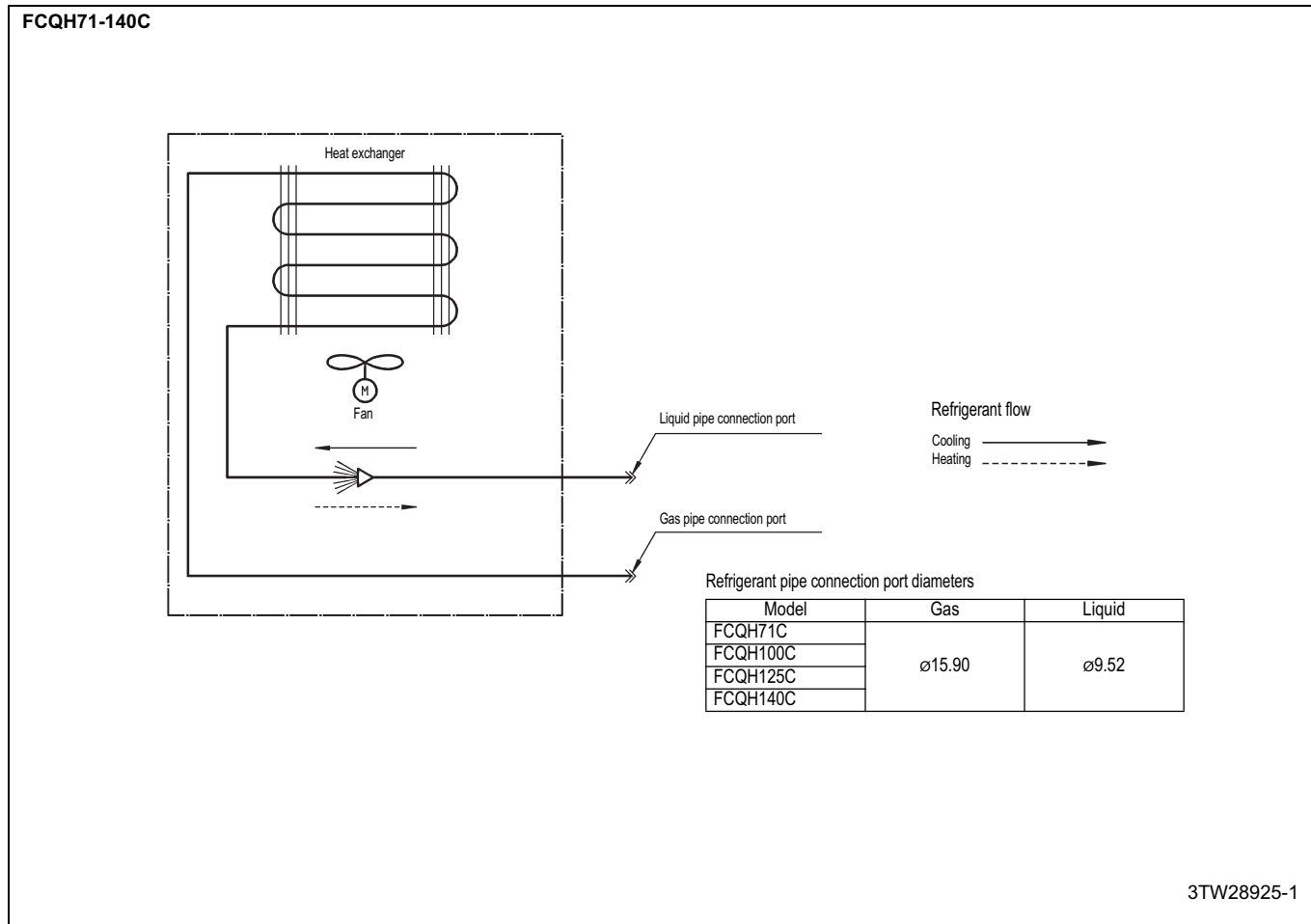

7 Wiring diagram

7 - 1 Wiring diagram

FCQH71-140C

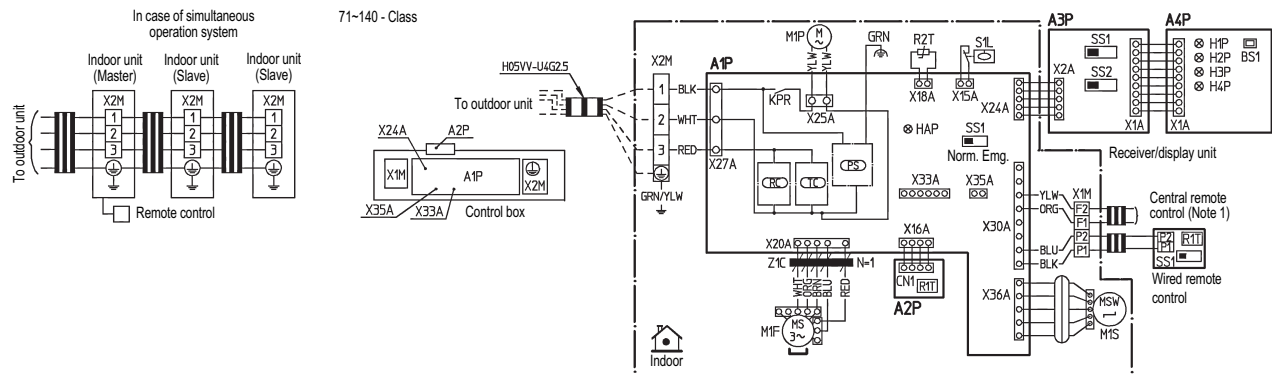

INDOOR UNIT		SS1	Selector switch (emergency)	H4P	Light emitting diode (defrost-orange)	
A1P	Printed circuit board	TC	Signal transmission circuit	SS1	Selector switch (main/sub)	
A2P	Printed circuit board (humidity sensor unit)	X1M	Terminal strip	SS2	Selector switch (wireless address set)	
HAP	Light emitting diode (service monitor green)	X2M	Terminal strip	CONNECTOR FOR OPTIONAL PARTS		
KPR	Magnetic relay (M1P)	Z1C	Ferrite core	X24A	Connector (infrared remote control)	
M1F	Motor (indoor fan)	RECEIVER/DISPLAY UNIT (ATTACHED TO INFRARED REMOTE CONTROL)			X33A	Connector (adapter for wiring)
M1P	Motor (drain pump)	A3P	Printed circuit board	X35A	Connector (group control adapter)	
M1S	Motor (swing flap)	A4P	Printed circuit board	INFRARED REMOTE CONTROL		
PS	Power supply circuit	BS1	Push button (on/off)	R1T	Thermistor (air)	
R1T	Thermistor (air)	SS1	Selector switch (main/sub)			
R2T	Thermistor (coil)	H1P	Light emitting diode (on-red)			
RC	Signal receiver circuit	H2P	Light emitting diode (timer-green)			
S1L	Float switch	H3P	Light emitting diode (filter sign-red)			

- : Terminal block
- , D : Connector
- : Field wiring

- Colors:
- RED: Red
 - BLK: Black
 - WHT: White
 - YLW: Yellow
 - GRN: Green
 - ORG: Orange
 - BRN: Brown
 - GRY: Grey
 - BLU: Blue

3TW28956-1

NOTES

- 1 In case of using central remote control, connect it to the unit in accordance with the attached installation manual.
- 2 X24A, X33A, and X35A are connected when the optional accessories are being used.
- 3 Remote control model varies according to the combination system, confirm engineering data and catalogs, etc. before connecting.
- 4 Confirm the method of setting the selector switch (SS1, SS2) by installation manual and engineering data, etc.

8 Sound data

8 - 1 Sound pressure spectrum

FCQH71C

4D056863

Scale	Mode	
	Hi	Low
A	34.0	28.0
C	40.0	34.0

Over All (dB): (B, G, N is already rectified)
 Operating conditions:
 • Power source: 220~240V 50Hz/220V 60Hz
 • Cooling: return air temperature: 27°C DB, 19°C WB - outdoor temperature: 35°C DB, 24°C WB
 • Heating: return air temperature: 20°C DB, 15°C WB - outdoor temperature: 7°C DB, 6°C WB
 • 4 direction discharge

Power level (dB): Hi | 52
 Measuring place: Anechoic chamber
 Location of microphone

Note: Operation noise differs with operation and ambient conditions.

FCQH100C

4D056864

Scale	Mode	
	Hi	Low
A	43.0	32.0
C	49.0	38.0

Over All (dB): (B, G, N is already rectified)
 Operating conditions:
 • Power source: 220~240V 50Hz/220V 60Hz
 • Cooling: return air temperature: 27°C DB, 19°C WB - outdoor temperature: 35°C DB, 24°C WB
 • Heating: return air temperature: 20°C DB, 15°C WB - outdoor temperature: 7°C DB, 6°C WB
 • 4 direction discharge

Power level (dB): Hi | 60
 Measuring place: Anechoic chamber
 Location of microphone

Note: Operation noise differs with operation and ambient conditions.

FCQH125C

4D056865

Scale	Mode	
	Hi	Low
A	43.0	36.0
C	49.0	42.0

Over All (dB): (B, G, N is already rectified)
 Operating conditions:
 • Power source: 220~240V 50Hz/220V 60Hz
 • Cooling: return air temperature: 27°C DB, 19°C WB - outdoor temperature: 35°C DB, 24°C WB
 • Heating: return air temperature: 20°C DB, 15°C WB - outdoor temperature: 7°C DB, 6°C WB
 • 4 direction discharge

Power level (dB): Hi | 60
 Measuring place: Anechoic chamber
 Location of microphone

Note: Operation noise differs with operation and ambient conditions.

FCQH140C

4D056866

Scale	Mode	
	Hi	Low
A	43.0	38.0
C	49.0	44.0

Over All (dB): (B, G, N is already rectified)
 Operating conditions:
 • Power source: 220~240V 50Hz/220V 60Hz
 • Cooling: return air temperature: 27°C DB, 19°C WB - outdoor temperature: 35°C DB, 24°C WB
 • Heating: return air temperature: 20°C DB, 15°C WB - outdoor temperature: 7°C DB, 6°C WB
 • 4 direction discharge

Power level (dB): Hi | 60
 Measuring place: Anechoic chamber
 Location of microphone

Note: Operation noise differs with operation and ambient conditions.

8 Sound data

8 - 2 Sound power spectrum

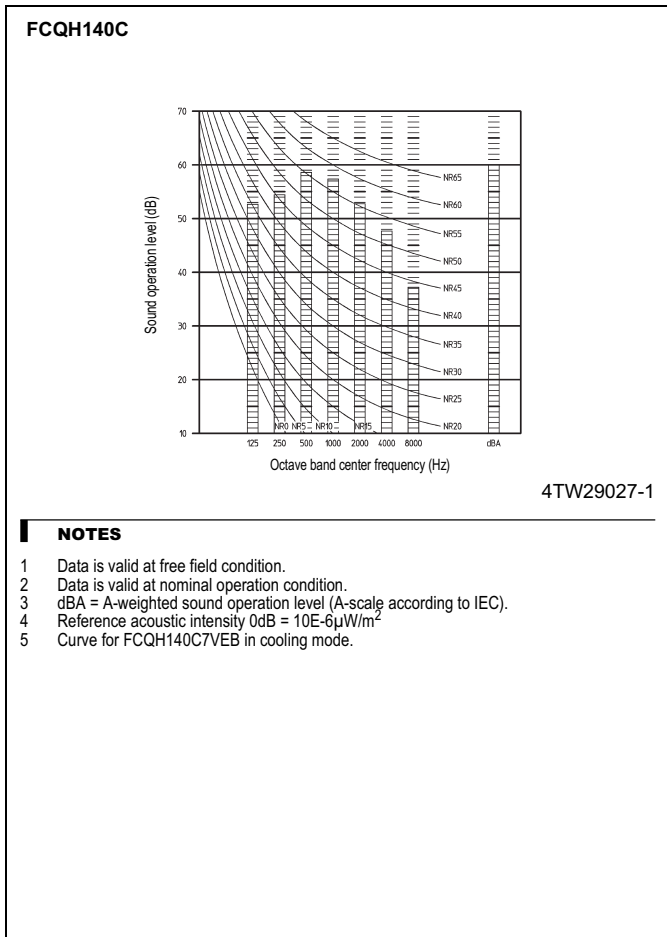
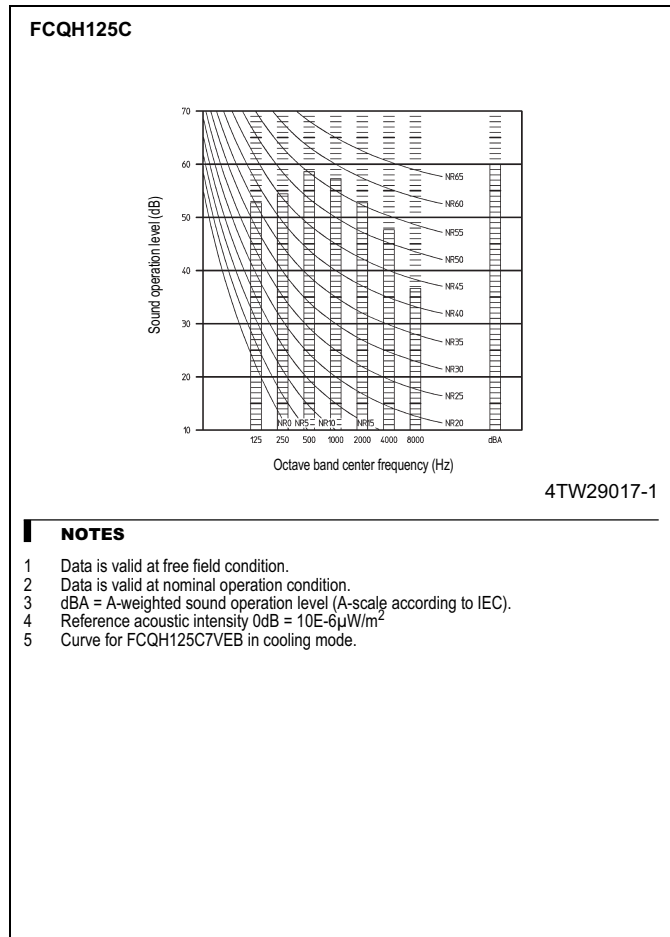
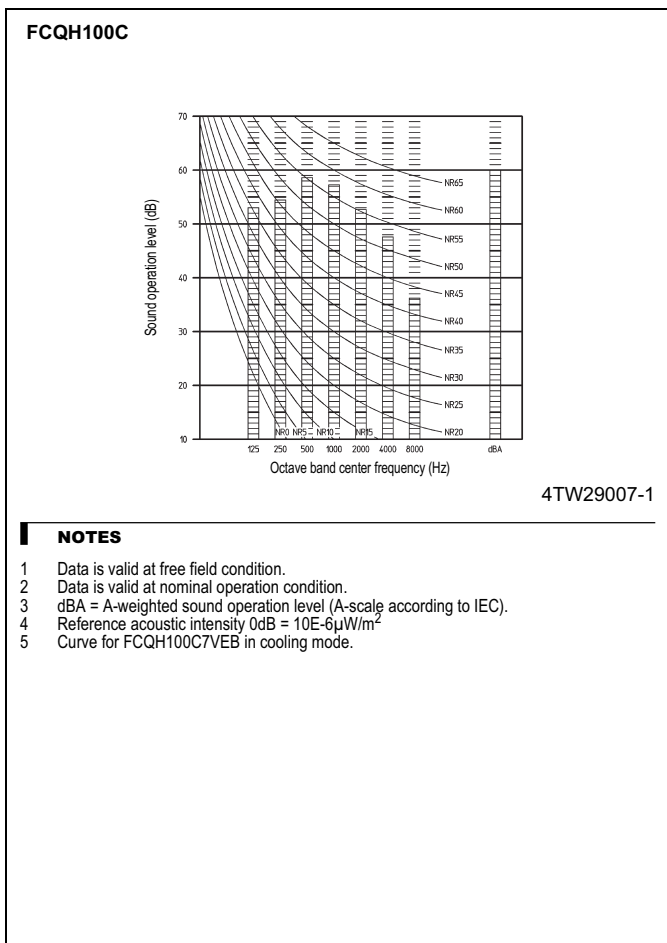
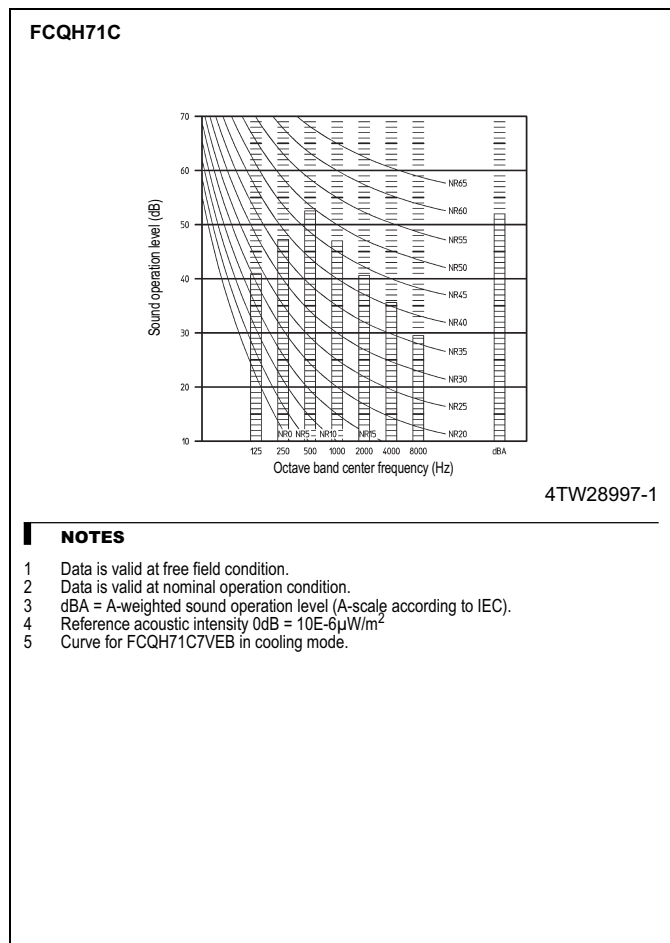

9 Air flow pattern

FCQH71C

Cooling air velocity distribution
 All round air discharge, air flow direction: horizontal

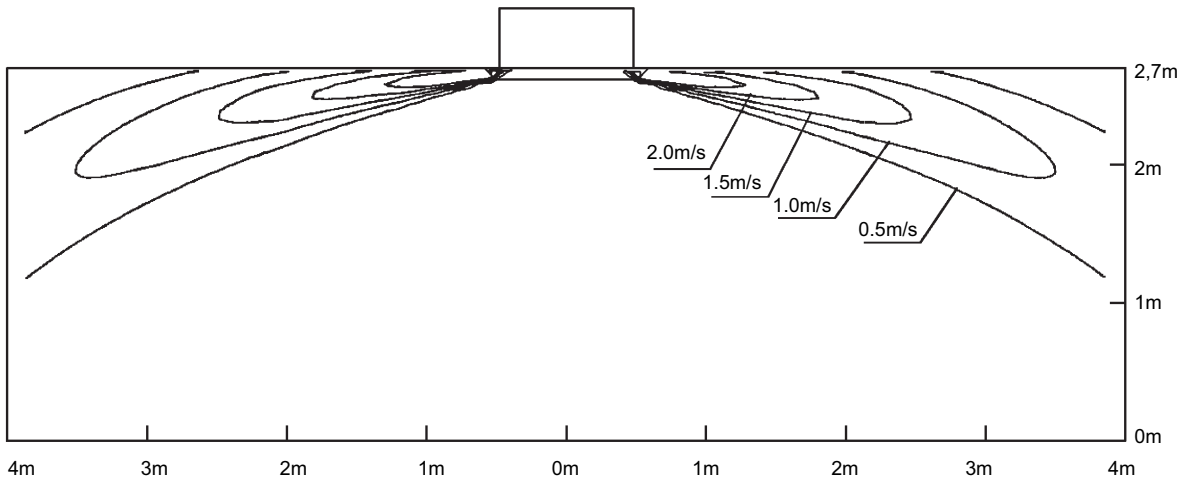

Cooling air temperature distribution
 All round air discharge, air flow direction: horizontal

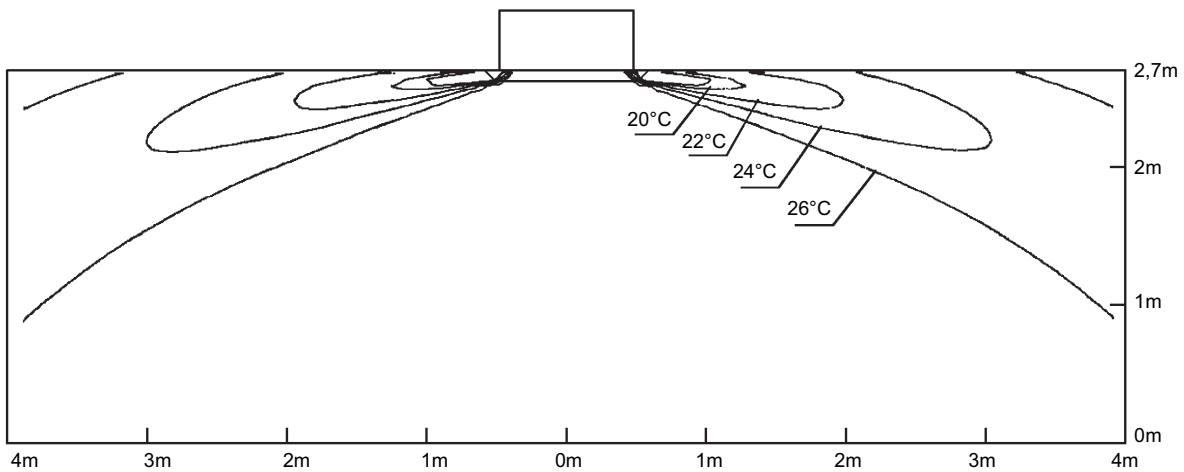

4D057213

9 Air flow pattern

FCQH100C

Cooling air velocity distribution
 All round air discharge, air flow direction: horizontal

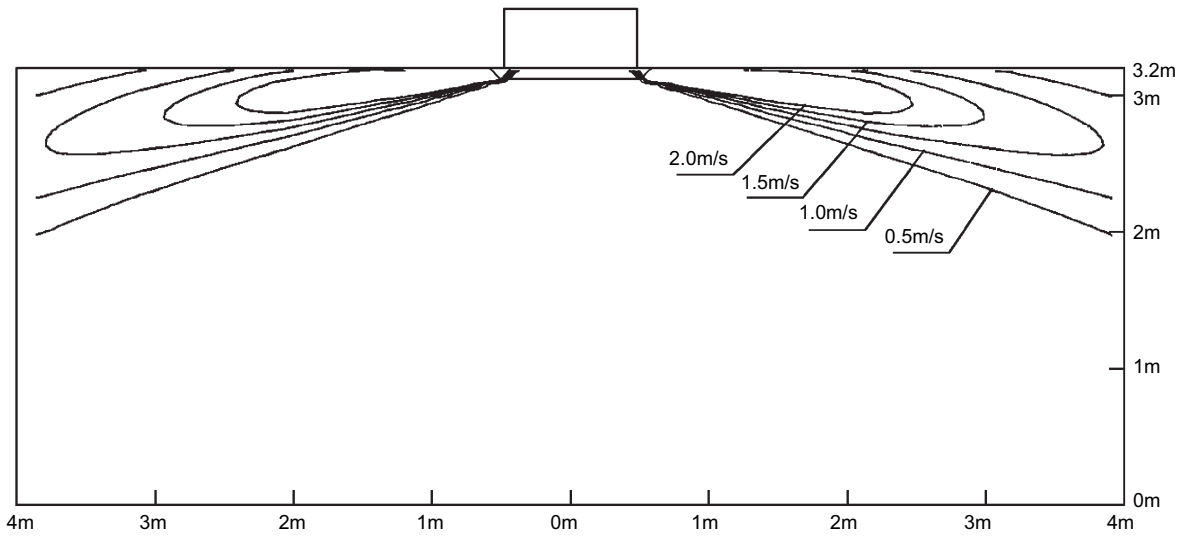

Cooling air temperature distribution
 All round air discharge, air flow direction: horizontal

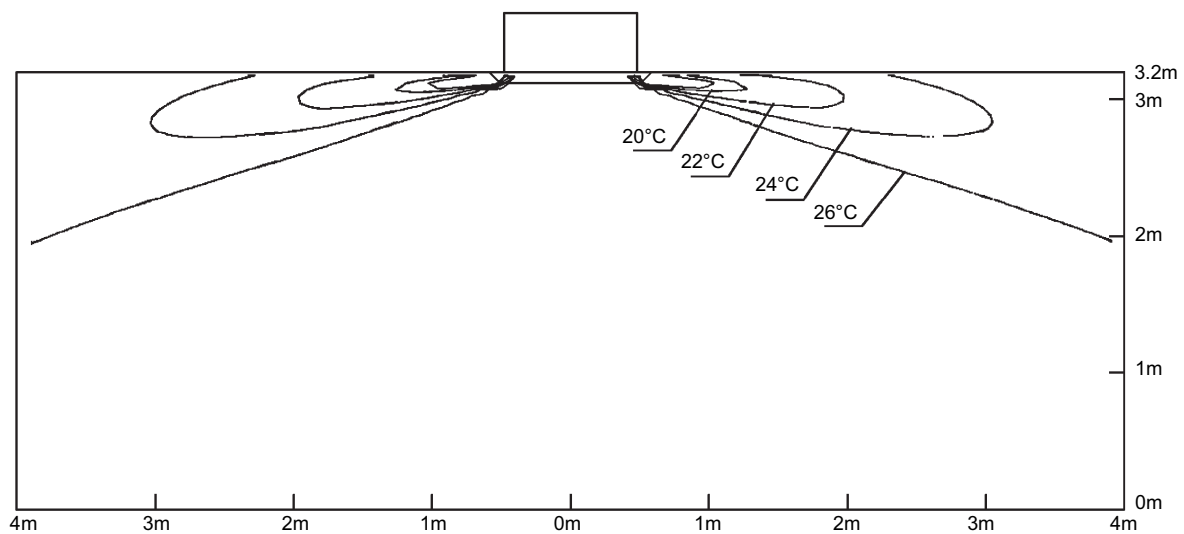

4D057215

30
9

9 Air flow pattern

FCQH125C

Cooling air velocity distribution
 All round air discharge, air flow direction: horizontal

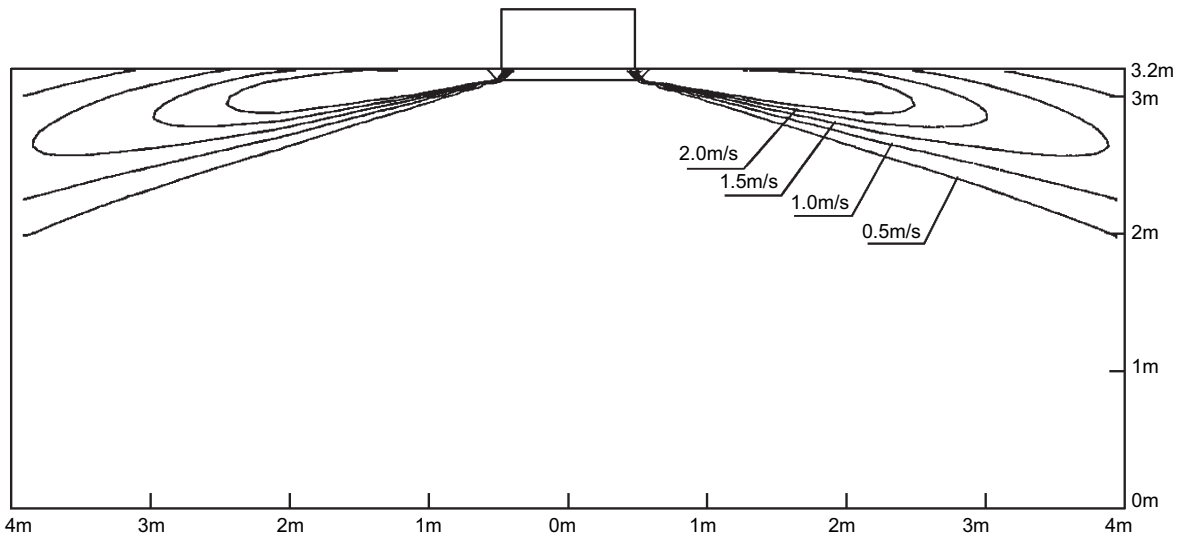

Cooling air temperature distribution
 All round air discharge, air flow direction: horizontal

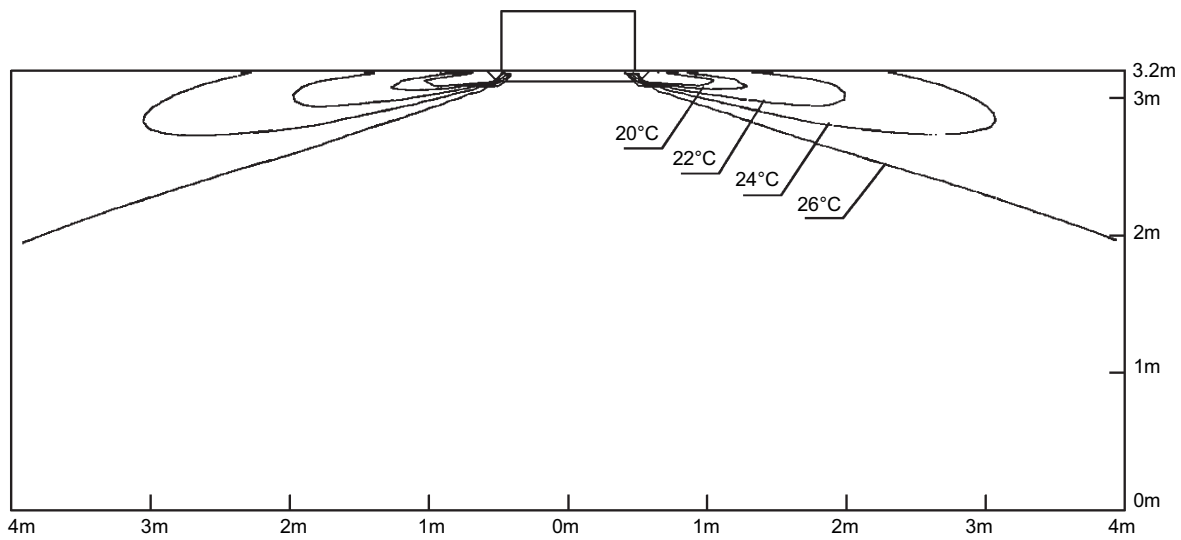

4D057217

9 Air flow pattern

FCQH140C

Cooling air velocity distribution
 All round air discharge, air flow direction: horizontal

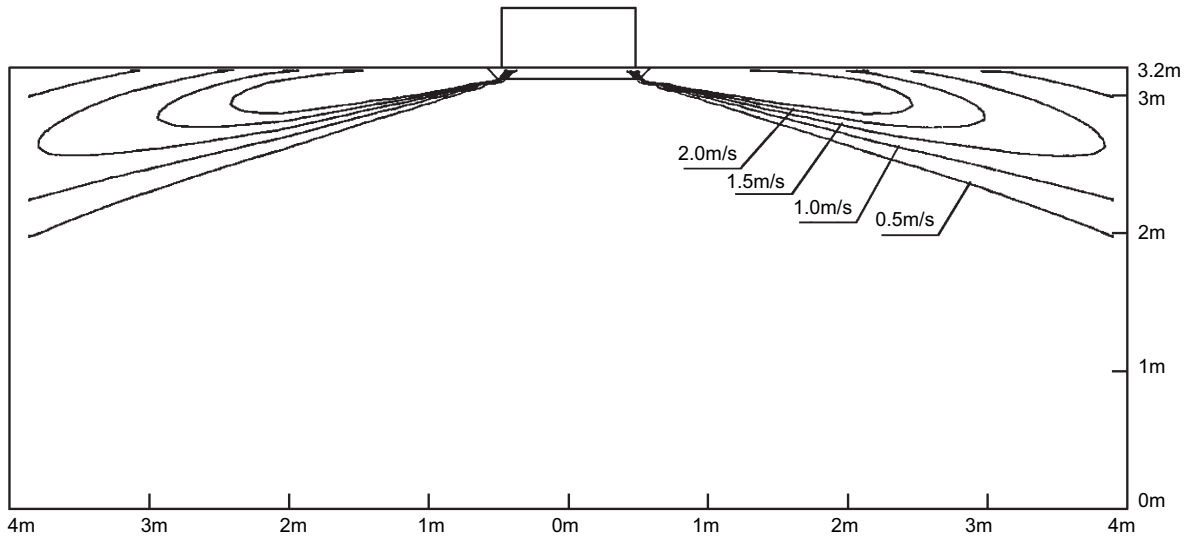

Cooling air temperature distribution
 All round air discharge, air flow direction: horizontal

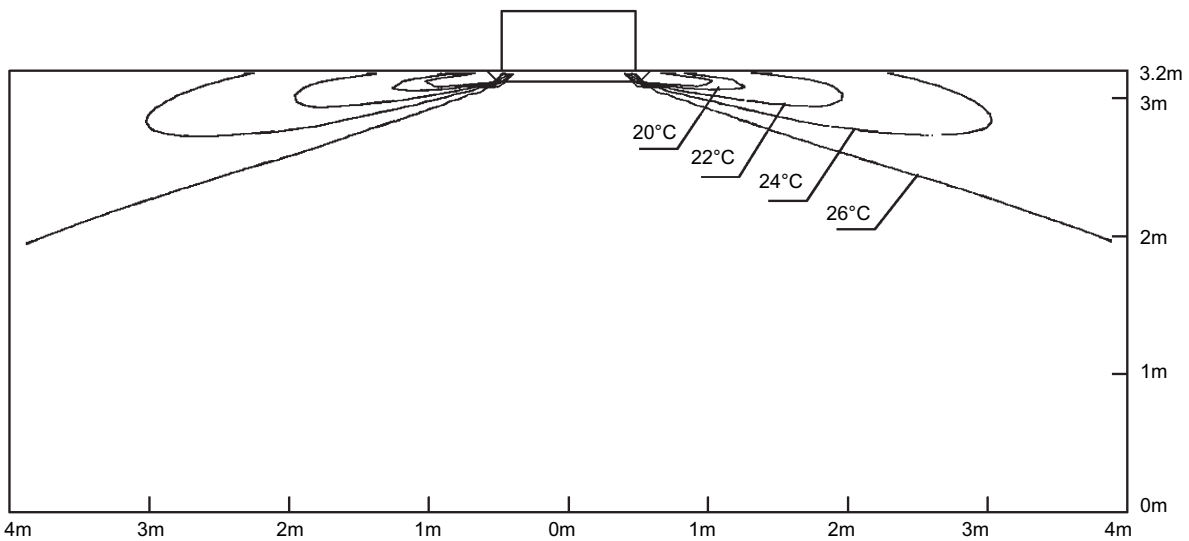

4D057219

9 Air flow pattern

FCQH71C

Heating air velocity distribution
 All round air discharge, air flow direction: horizontal

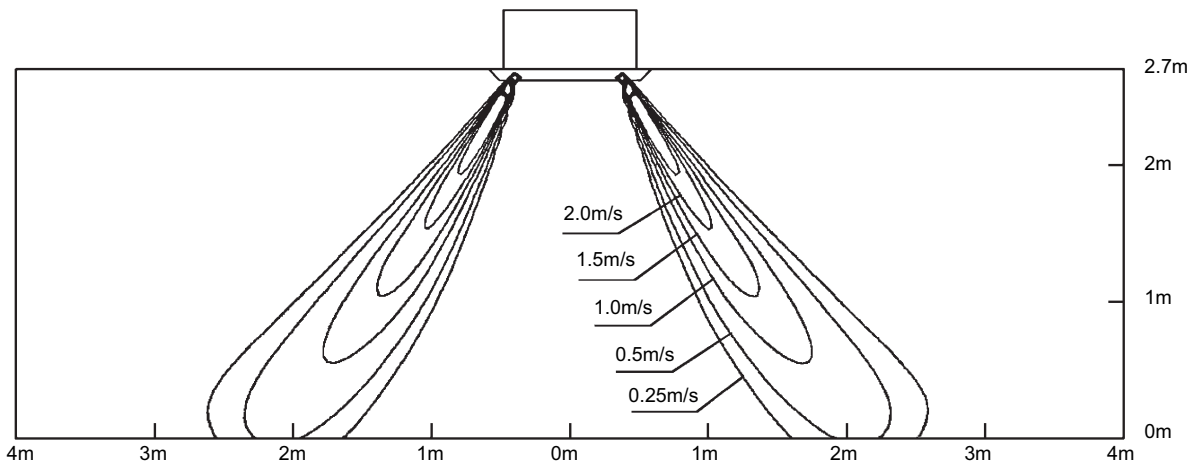

Heating air temperature distribution
 All round air discharge, air flow direction: horizontal

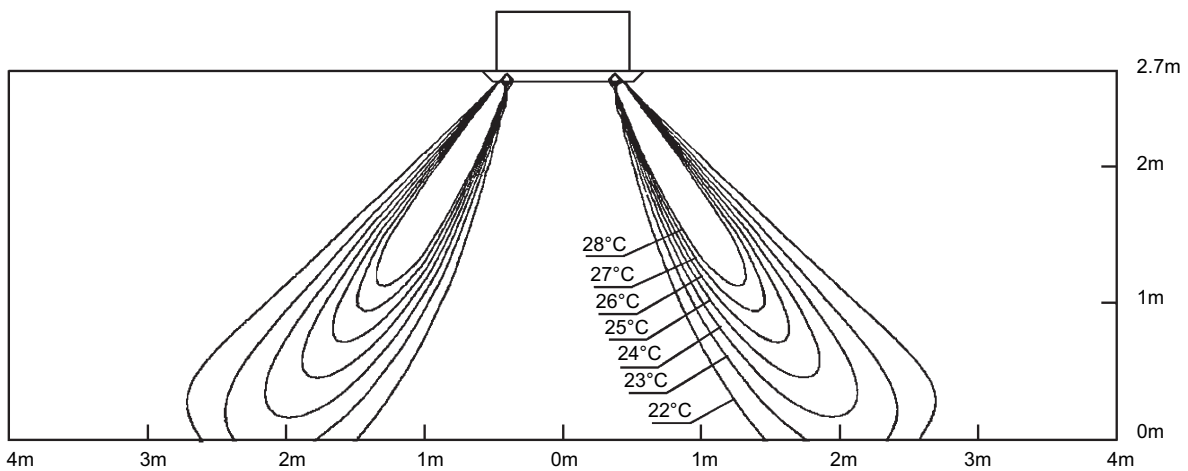

4D057212

9 Air flow pattern

FCQH100C

Heating air velocity distribution
All round air discharge, air flow direction: horizontal

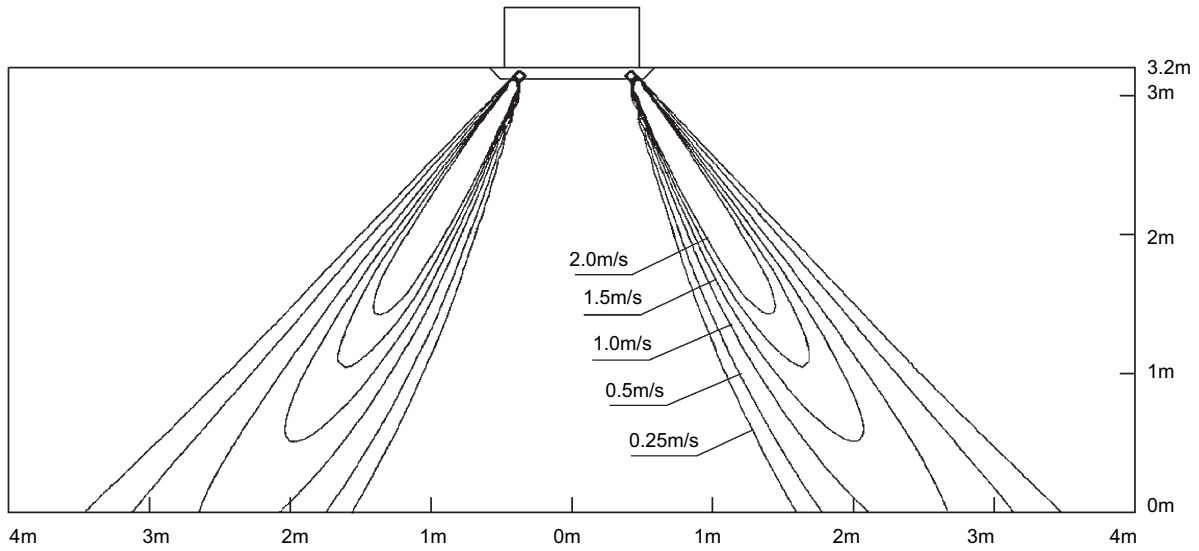

Heating air temperature distribution
All round air discharge, air flow direction: horizontal

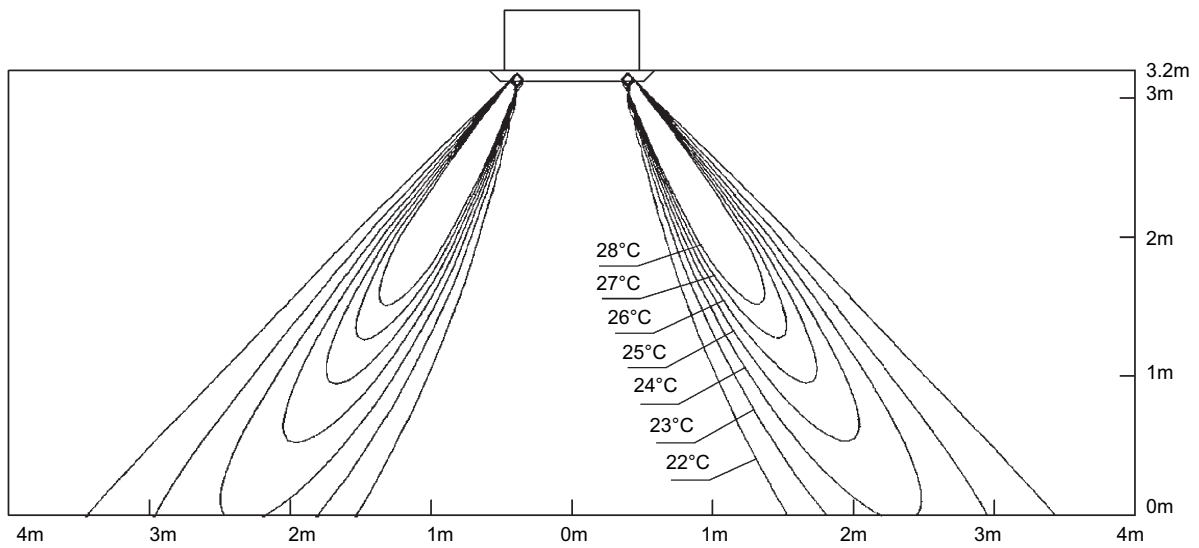

4D057214

9 Air flow pattern

FCQH125C

Heating air velocity distribution
 All round air discharge, air flow direction: horizontal

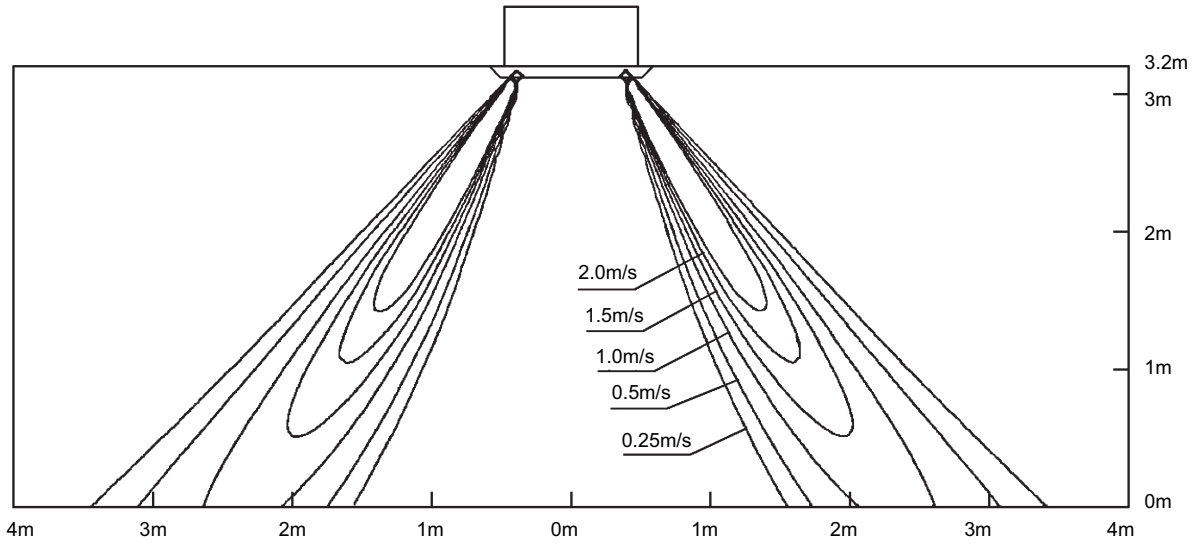

Heating air temperature distribution
 All round air discharge, air flow direction: horizontal

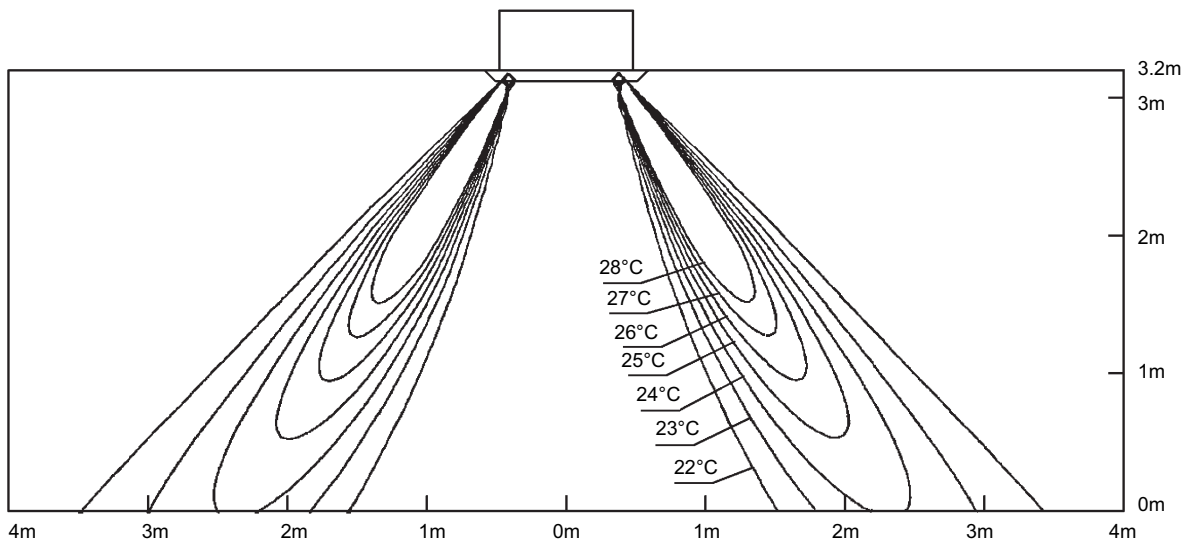

4D057216

9 Air flow pattern

FCQH140C

Heating air velocity distribution
 All round air discharge, air flow direction: horizontal

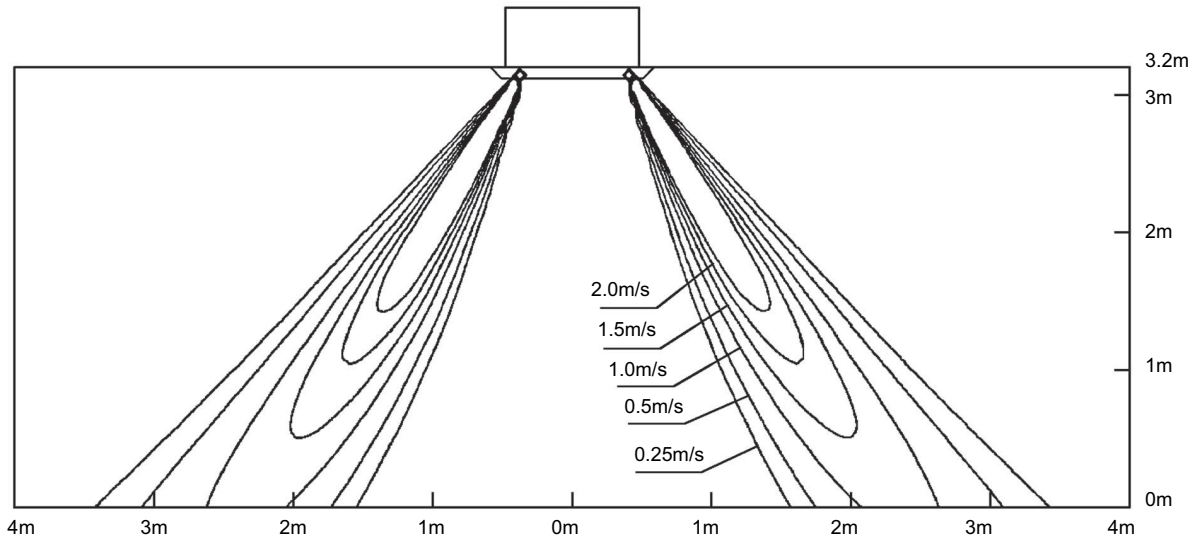

Heating air temperature distribution
 All round air discharge, air flow direction: horizontal

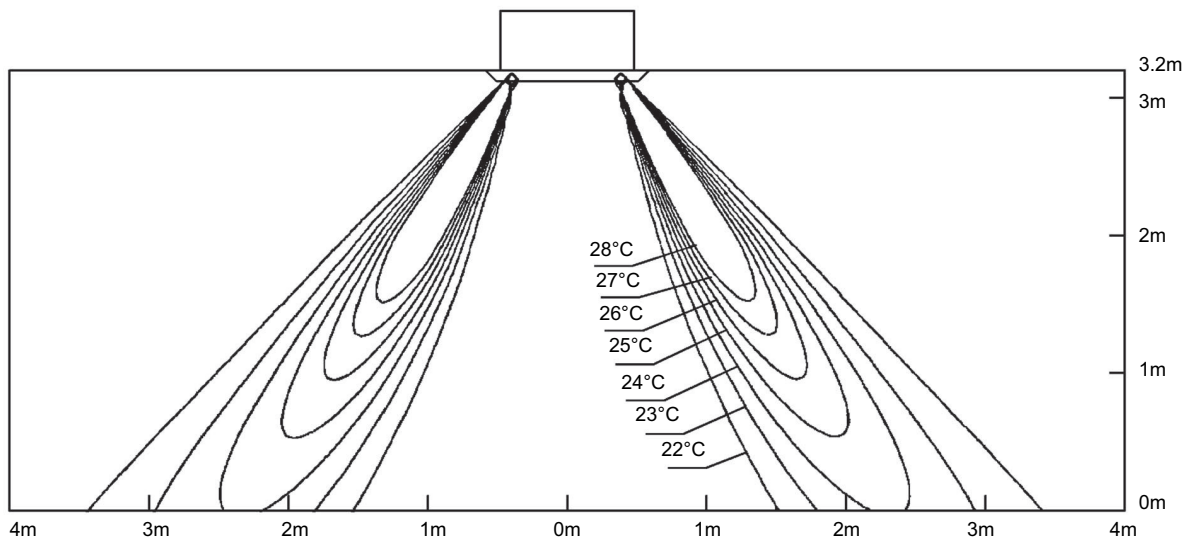

4D057218

30
9