

# technical data

FDQ-B8V3B9

air conditioning systems

Split  
Sky Air

**R-410A**

# Split - Sky Air

In all of us,  
a green heart



Daikin's unique position as a manufacturer of air conditioning equipment, compressors and refrigerants has led to its close involvement in environmental issues. For several years Daikin has had the intention to become a leader in the provision of products that have limited impact on the environment. This challenge demands the eco design and development of a wide range of products and an energy management system, resulting in energy conservation and a reduction of waste.



Het ISO14001 assures an effective environmental management system in order to help protect human health and the environment from potential impact of our activities, products and services and to assist in maintaining and improving the quality of the environment.



Daikin Europe N.V. is approved by LRQA for its Quality Management System in accordance with the ISO9001 standard. ISO9001 pertains to quality assurance regarding design, development, manufacturing as well as to services related to the product.



Daikin units comply with the European regulations that guarantee the safety of the product.



Daikin Europe N.V. participates in the Eurovent Certification Programme for Air Conditioners (AC), Liquid Chilling Packages (LCP) and Fan Coil Units (FC); the certified data of certified models are listed in the Eurovent Directory.

"The present publication is drawn up by way of information only and does not constitute an offer binding upon Daikin Europe N.V. Daikin Europe N.V. has compiled the content of this publication to the best of its knowledge. No express or implied warranty is given for the completeness, accuracy, reliability or fitness for particular purpose of its content and the products and services presented therein. Specifications are subject to change without prior notice. Daikin Europe N.V. explicitly rejects any liability for any direct or indirect damage, in the broadest sense, arising from or related to the use and/or interpretation of this publication. All content is copyrighted by Daikin Europe N.V."

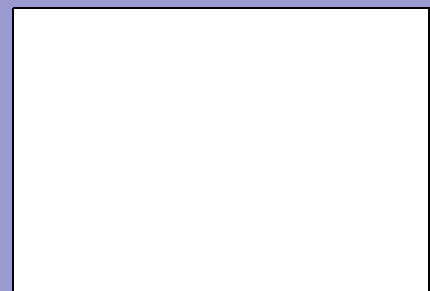

## DAIKIN EUROPE N.V.

Naamloze Vennootschap

Zandvoordestraat 300

B-8400 Ostend, Belgium

www.daikin.eu

BTW: BE 0412 120 336

RPR Oostende

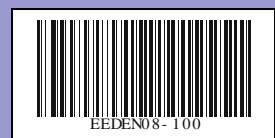

# technical data

FDQ-B8V3B9

air conditioning systems

Split  
Sky Air

**R-410A**

# TABLE OF CONTENTS

## FDQ-B8V3B9

1	Features .....	5
2	Specifications .....	6
	For indoor units only .....	6
	Technical Specifications .....	6
	Electrical Specifications .....	7
3	Options .....	8
4	Control systems .....	9
5	Dimensional drawing & centre of gravity .....	10
	Dimensional drawing .....	10
6	Piping diagram .....	11
7	Wiring diagram .....	12
	Wiring diagram .....	12
8	Sound data .....	13
	Sound pressure spectrum .....	13
	Sound power spectrum .....	14
9	Fan characteristics .....	15
10	Installation .....	16
	Installation method .....	16

# 1 Features

- Slim design for flexible installation
- Ideal for use in larger areas
- Blends unobtrusively with any interior décor: only the suction and discharge grilles are visible
- Maximum external static pressure (ESP) ranges from 150 till 250Pa
- Optimum air distribution

1

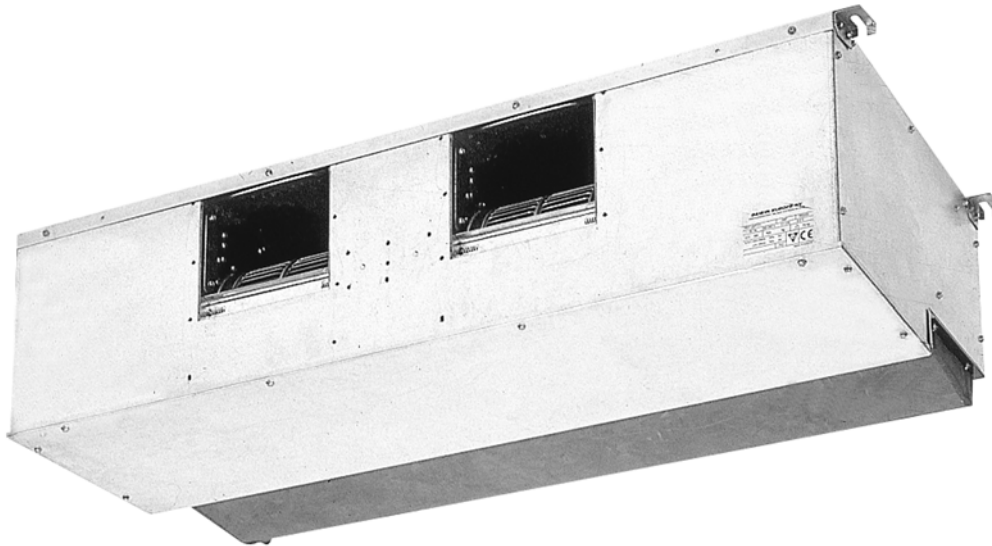

heat pump



standard



optional



2 steps:  
FDQ250, 3  
steps:  
FDQ125,200



optional



## 2 Specifications

2-1 FOR INDOOR UNITS ONLY			FDQ125B8V3B9	FDQ200B8V3B9	FDQ250B8V3B9
Nominal input (Indoor only)	Cooling	kW		1,340	1,340
	Heating	kW		1,340	1,340

2-2 TECHNICAL SPECIFICATIONS				FDQ125B8V3B9	FDQ200B8V3B9	FDQ250B8V3B9
Casing	Colour			Non painted		
	Material			Galvanised steel		
Dimensions	Packing	Height	mm	512	607	607
		Width	mm	1,515		
		Depth	mm	795	1,055	1,055
	Unit	Height	mm	350	450	450
		Width	mm	1,400		
		Depth	mm	662	900	900
Weight	Unit	kg	59.0	89.0	94.0	
	Packed Unit	kg	74.0	108.0	113.0	
Required Ceiling Void		mm	350	450	450	
Heat Exchanger	Dimensions	Length	mm	1,150	1,200	1,200
		Nr of Rows		3	3	3
		Fin Pitch	mm	1.75	2.00	2.00
		Nr of Passes		10	12	12
		Face Area	m <sup>2</sup>	0.338	0.634	0.634
		Nr of Stages		14	24	24
	Tube type			Hi-XSS (7)	Hi-XSS (8)	Hi-XSS (8)
	Fin	Type		Rhombus	Non-symmetric fin	Non-symmetric fin
Treatment			Hydrophilic			
Fan	Type			Sirocco fan		
	Quantity			2	2	2
Air Flow Rate	Cooling	Medium	m <sup>3</sup> /min	43.0	69.0	89.0
	Heating	Medium	m <sup>3</sup> /min	43.0	69.0	89.0
Fan	Max	High	Pa	150	250	250
		Standard	Pa	150	250	250
		Low	Pa	150	250	250
	Motor	Quantity		1	1	1
		Model		DPA216-178NB	DPC241-241NB	DPC241-241NB
		Number of steps		3	3	2
		Output (high)	W	500	650	1,000
		Drive		Direct drive		
Cooling	Sound Power	Medium	dBA	75.0	81.0	82.0
	Sound Pressure	High	dBA	44.0	45.0	47.0
Heating	Sound Pressure	Low	dBA	44.0	45.0	47.0
Refrigerant	Type			R-410A		
Piping connections	Liquid (OD)	Type		Flare connection		
		Diameter (OD)	mm	9.52	9.52	12.7
	Gas	Type		Flare connection	Braze connection	Braze connection
		Diameter (OD)	mm	15.9	22.2	22.2
	Drain	Diameter (OD)	mm		25	25
	Heat Insulation			Both liquid and gas pipes		
Air Filter	Resin net with mold resistance					
Air direction control	Up and downwards					
Temperature control	Microprocessor thermostat for cooling and heating					
Safety Devices	Fan motor thermal fuse					
Standard Accessories	Item			Installation and operation manual		
	Quantity			1	1	1

## 2 Specifications

2

2-2 TECHNICAL SPECIFICATIONS	FDQ125B8V3B9	FDQ200B8V3B9	FDQ250B8V3B9
Notes	Sound values are measured in a semi-anechoic room with corrections		
	The sound pressure level is measured via a microphone at 1m distance of the unit.		
	Sound pressure level is a relative value, depending on the distance and acoustic environment. For more details, please refer to sound level drawings of this chapter.		
	The sound power level is an absolute value indicating the power which a sound source generates.		

2-3 ELECTRICAL SPECIFICATIONS		FDQ125B8V3B9	FDQ200B8V3B9	FDQ250B8V3B9
Power Supply	Name	V3		
	Phase	1~		
	Frequency	Hz	50	50
	Voltage	V	230	230
Voltage range	Minimum	-10%		
	Maximum	+10%		
Power Supply Intake		Both indoor and outdoor unit		
Notes		FOR MORE DETAILS, REFER TO WIRING DIAGRAM, NAME PLATE AND INSTALLATION MANUAL		

### 3 Options

FDQ-B		
Name of option		FDQ125-200-250B
Wiring adaptor for electrical appendices		KRP4A51
Adapter for wiring (interlock for fresh air intake)		KRP1B54
Interface adapter for Sky Air series		DTA112B51
Central remote control		DCS302C51
unified ON/OFF control		DCS301B51
Schedule timer		DST301B51
Option PCB for electrical heater, humidifier and/or hour meter. *1		EKRP1B2
Remote control	Wired type	BRC1D52
Remote ON/OFF, forced OFF		EKRORO

3TW22809-1F

\*1 Electrical heater, humidifier and hour meter are field supply. These parts should not be installed inside the equipment. (Refer to installation manual EKRP1B2).



## 4 Control systems

BRC1D52

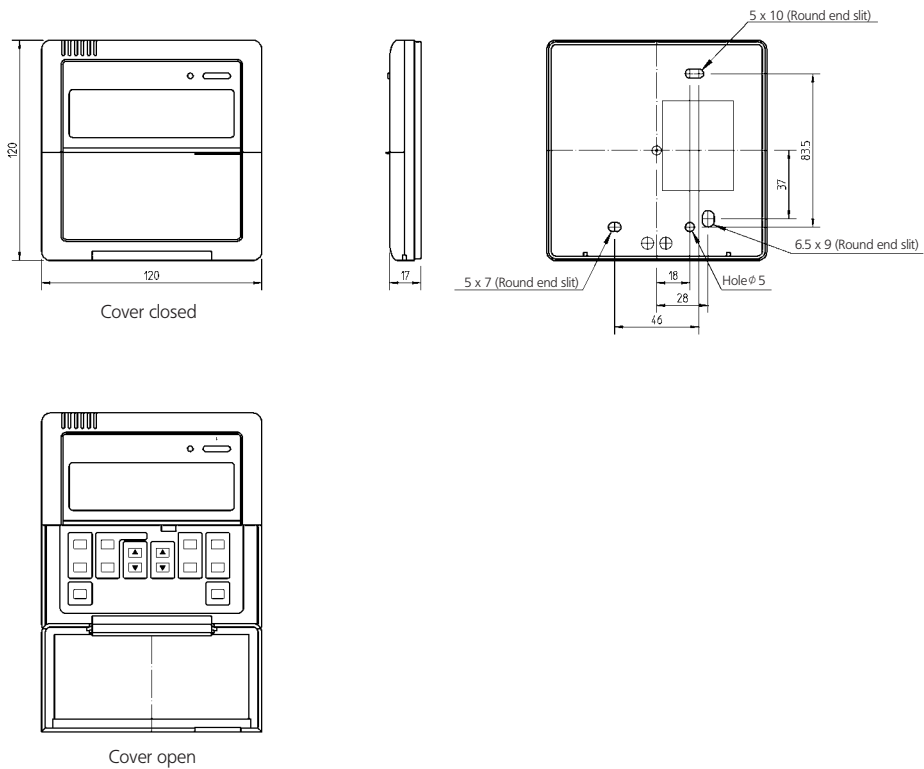

3TW23651-2

# 5 Dimensional drawing & centre of gravity

## 5 - 1 Dimensional drawing

**FDQ125B** unit (mm)

View A

① Power supply intake  
 ② Drain connection  $\phi$  25 O.D.  
 ③ Gas pipe connection single union joint 5/8" or 15,9 mm  
 ④ Liquid pipe connection single union joint 3/8" or 9,52 mm  
 ⑤ Filter

Notes:  
 : Service space

3TW30824-1

**FDQ200-250B**  
**FDYP200-250B** unit (mm)

View A

① Power supply intake  
 ② Drain connection  $\phi$  25 O.D.  
 ③ Gas pipe connection  
 FDYP200B/250B : 1 1/8" O.D. or 28,6 mm  
 FDQ200/250 : 7/8" O.D. or 22,2 mm O.D.  
 ④ Liquid pipe connection  
 FDYP200B : Single union joint 1/2" or 12,7mm  
 FDYP250B : Single union joint 5/8" or 15,9mm  
 FDQ200 : Single union joint 3/8" or 9,52 mm  
 FDQ250 : Single union joint 1/2" or 12,7mm  
 ⑤ Filter

Notes:  
 : Service space

Model	A	B
FDYP200B8V19/FDQ200B8V3B9	830	285
FDYP250B8V19/FDQ250B8V3B9	890	255

3TW30844-1

# 6 Piping diagram

6

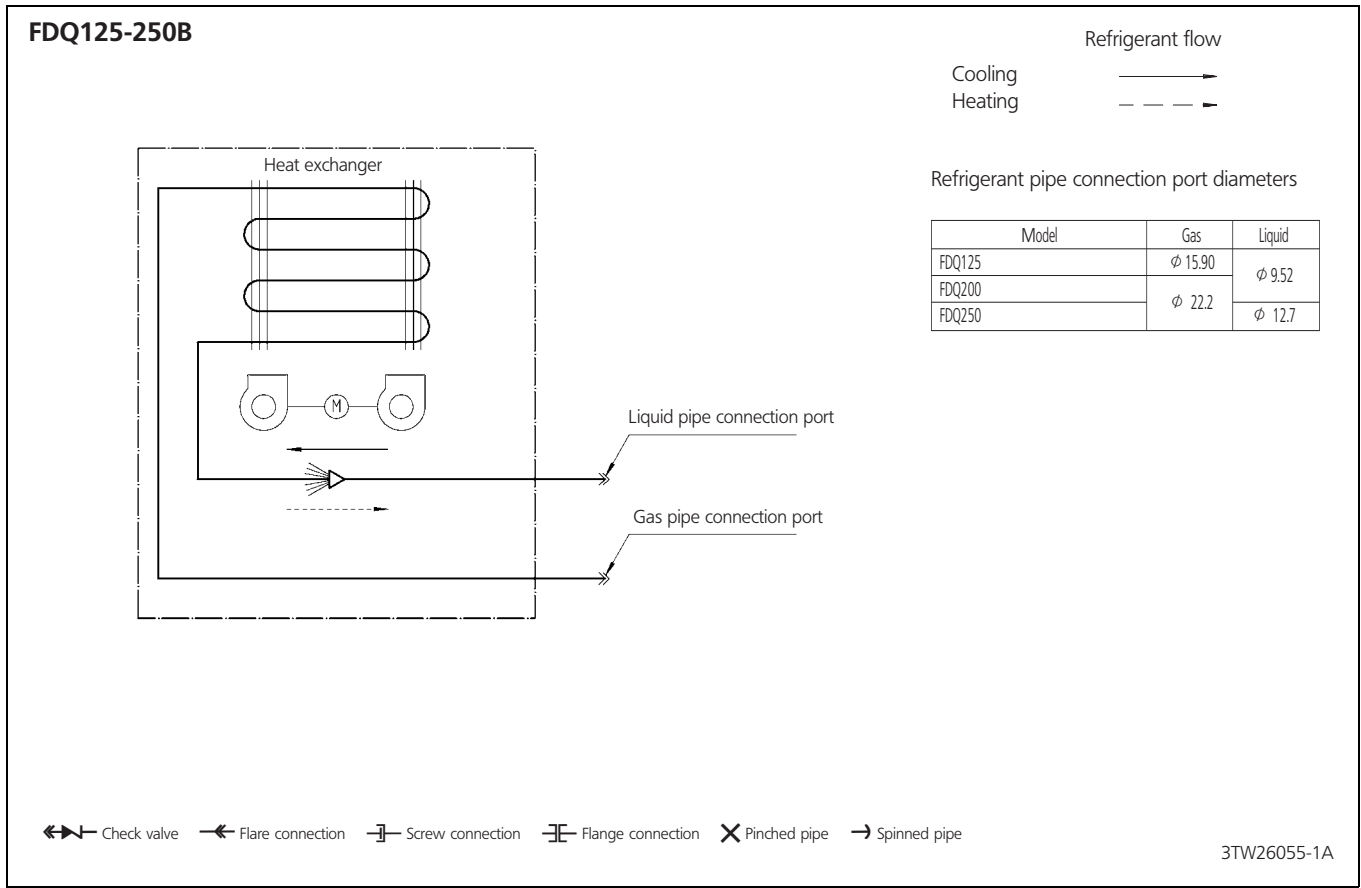

# 7 Wiring diagram

## 7 - 1 Wiring diagram

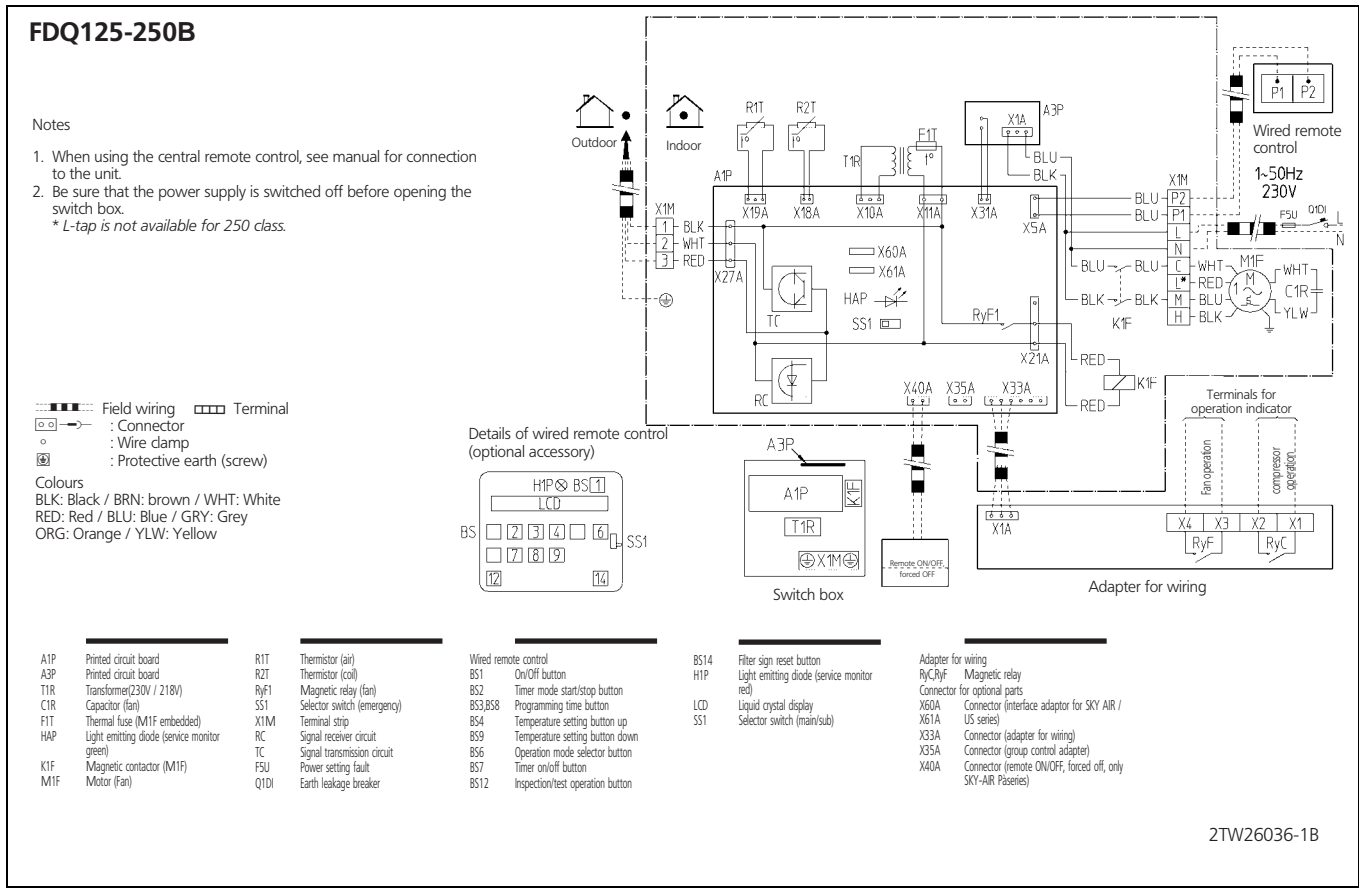

# 8 Sound data

## 8 - 1 Sound pressure spectrum

8

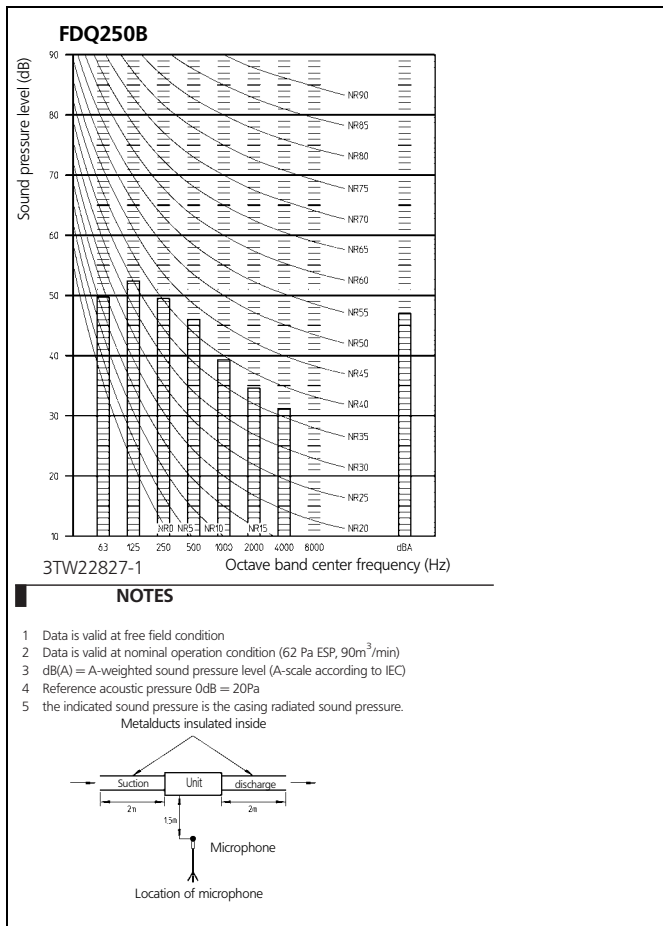
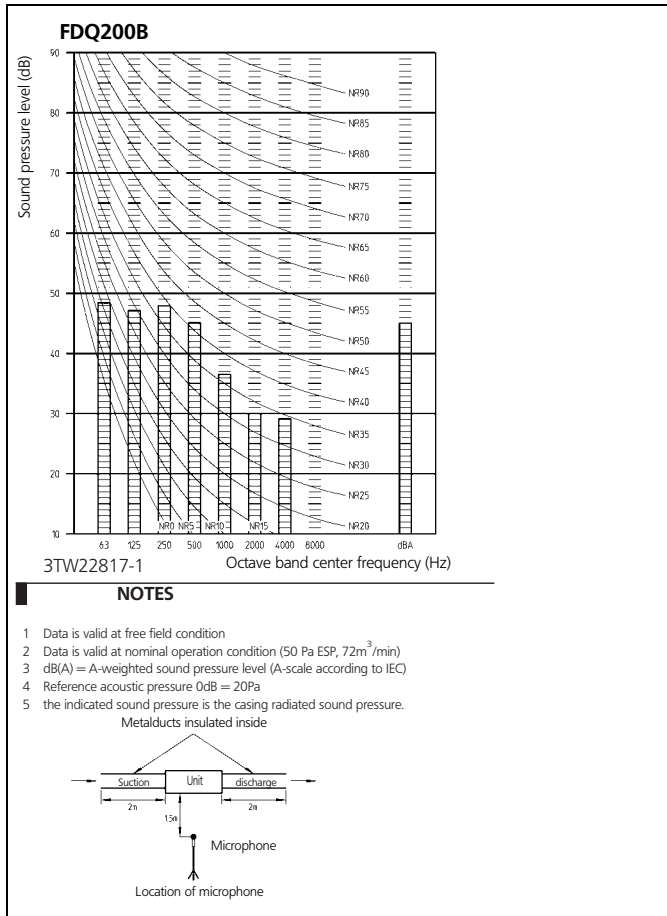
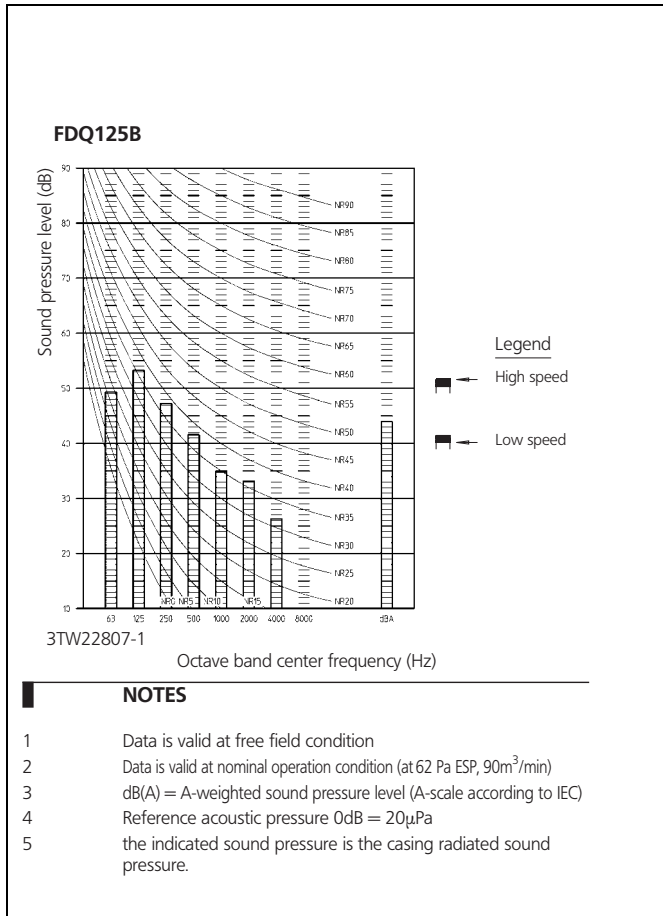

# 8 Sound data

## 8 - 2 Sound power spectrum

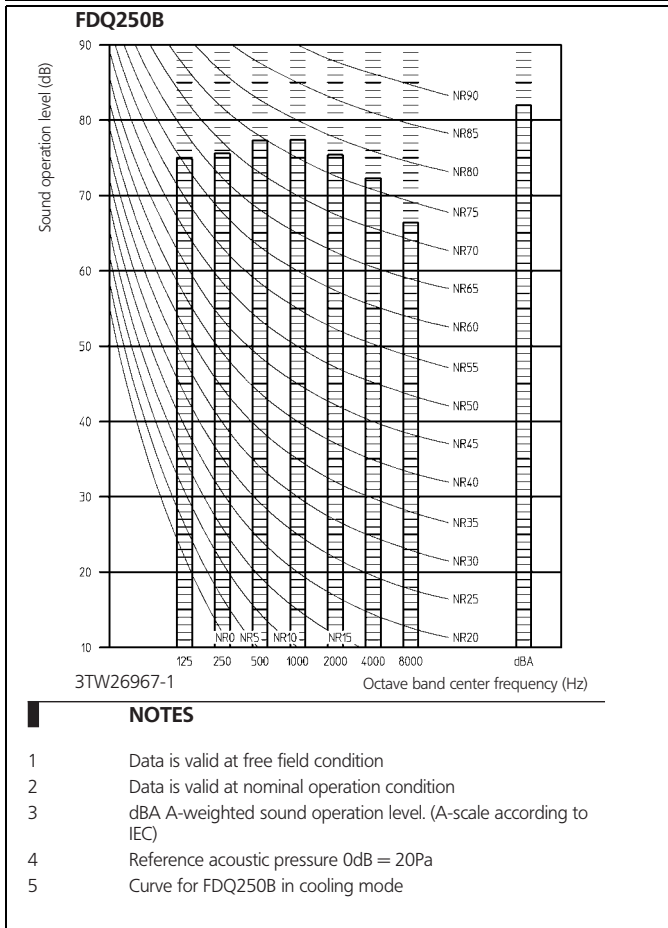
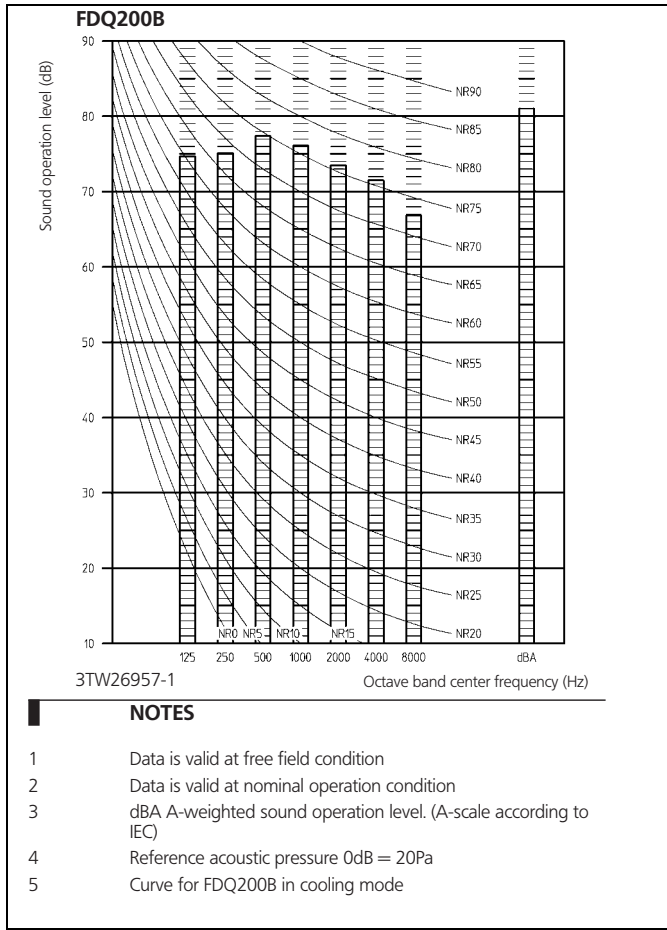
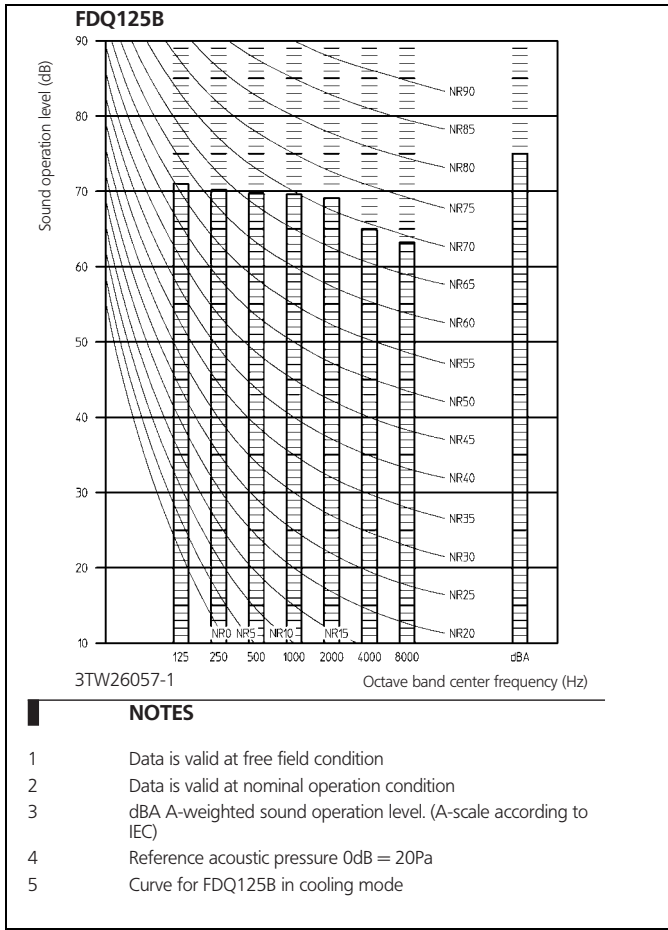

# 9 Fan characteristics

9

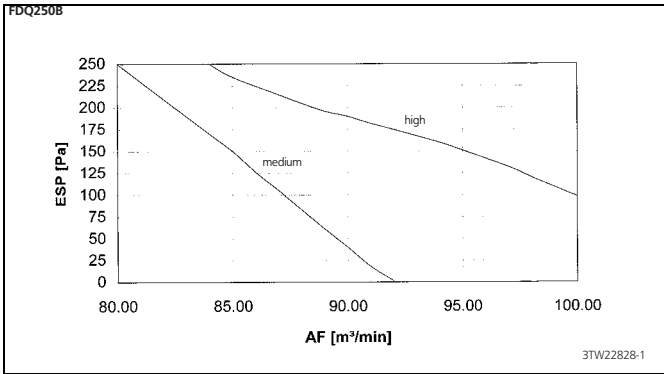
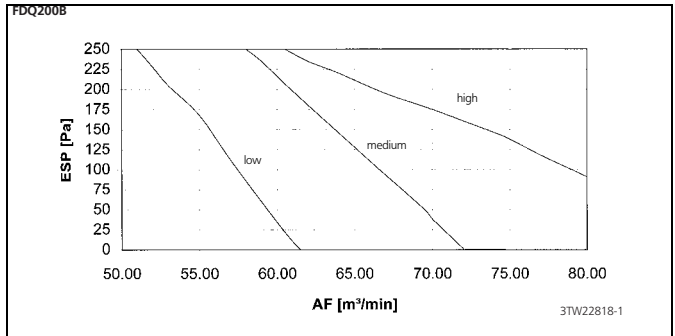
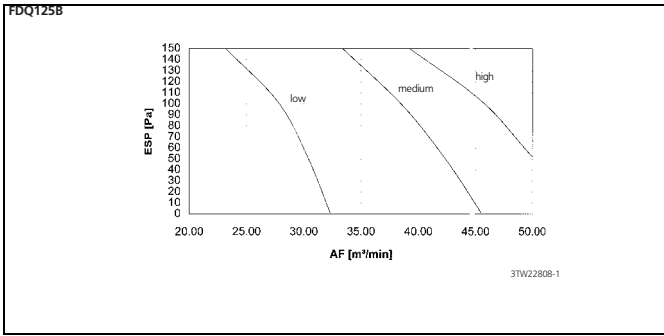

# 10 Installation

## 10 - 1 Installation method

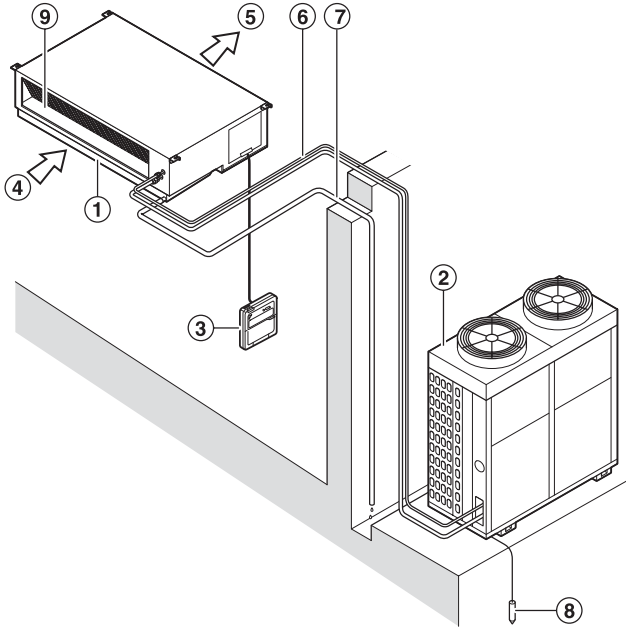

Number	Description
1	Indoor unit
2	Outdoor unit
3	Remote control
4	Inlet air
5	Discharged air
6	Refrigerant piping, connection electric wire
7	Drain pipe
8	Ground wire Wire to ground from the outdoor unit to prevent electrical shocks.
9	Air filter



## 10 Installation

### 10 - 1 Installation method