



technical data

FDYMP-L7



Concealed Ceiling Unit



air conditioning systems

Split Sky Air

Split - Sky Air



ISO14001 assures an effective environmental management system in order to help protect human health and the environment from the potential impact of our activities, products and services and to assist in maintaining and improving the quality of the environment



Daikin units comply with the European regulations that guarantee the safety of the product.



Daikin Europe N.V. is approved by LRQA for its Quality Management System in accordance with the ISO9001 standard. ISO9001 pertains to quality assurance regarding design, development, manufacturing as well as to services related to the product.



Daikin Europe N.V. is participating in the EUROVENT Certification Programme. Products are as listed in the EUROVENT Directory of Certified Products.

Specifications are subject to change without prior notice.

DAIKIN EUROPE N.V.

Zandvoordestraat 300
B - 8400 Ostend Belgium
Internet: <http://www.daikineurope.com>



TABLE OF CONTENTS

FDYMP-L

1	Features	2
2	Specifications	3
	Nominal capacity, capacity steps and nominal input	
	Technical specifications	
3	Dimensional drawings	6
4	Piping diagrams	7
5	Wiring diagrams	8
6	Sound level	9
	Sound level data	
	Sound pressure spectrum	
	Sound power spectrum	
7	Fan characteristics	11
8	Accessories	12
	Optional accessories	
9	Control systems	13
10	Center of gravity	14
11	Safety device settings	14
12	Installation	15

* For capacity tables, please refer to part II: outdoor units





1 Features

1

- Lightweight and compact: the depth of the unit is just 279mm for all capacity sizes.
- Both discharge and suction ducts can be easily connected via flanges on the unit.
- The air filter is easily accessible from underneath, even after the installation of the ducts.
- Silent in operation both indoors and outdoors: sound pressure for the indoor units as low as 37dB(A)
- Numerous optional control facilities



Optional



2 steps





2 Specifications

2

NOMINAL CAPACITY and NOMINAL INPUT					
For indoor units only:					
INDOOR UNITS			FDYMP71L7V1	FDYMP100L7V1	FDYMP125L7V1
NOMINAL INPUT	Cooling	kW	-	-	-
	Heating	kW	-	-	-

For combination indoor + outdoor units (air cooled):					
INDOOR UNITS			FDYMP71L7V1	FDYMP100L7V1	FDYMP125L7V1
OUTDOOR UNITS			RP71L7V1/W1-RP71B7T1	RP100L7V1/W1-RP100B7T1	RP125L7W1-RP125B7T1
NOMINAL CAPACITY (3)	Cooling	kW	7.10	10.00	12.20
	Heating	kW	-	-	-
NOMINAL INPUT	Cooling	kW	2.60/2.66	3.75/3.72	4.62
EER			2.67/2.73	2.66/2.69	2.64
ENERGY LABEL	Cooling		D/D	D/D	D/D
ANNUAL ENERGY CONSUMPTION	Cooling	kWh	1,330/1,300	1,875/1,860	2,310

For combination indoor + outdoor units (air cooled):					
INDOOR UNITS			FDYMP71L7V1	FDYMP100L7V1	FDYMP125L7V1
OUTDOOR UNITS			RYP71L7V1/W1	RYP100L7V1/W1	RYP125L7W1
NOMINAL CAPACITY (3)	Cooling	kW	7.10	10.00	12.20
	Heating	kW	8.00	11.00	14.50
NOMINAL INPUT	Cooling	kW	2.61/2.55	3.68/3.65	4.55
	Heating	kW	2.48/2.43	3.75/3.72	4.34
EER			2.72/2.78	2.72/2.74	2.68
COP			3.21/3.29	2.93/2.96	3.34
ENERGY LABEL	Cooling		D/D	D/D	D
	Heating		C/C	D/D	C
ANNUAL ENERGY CONSUMPTION	Cooling	kWh	1,305/1,275	1,840/1,825	2,275

For combination indoor + outdoor units (air cooled):					
INDOOR UNITS			FDYMP71L7V1	FDYMP100L7V1	FDYMP125L7V1
OUTDOOR UNITS			RYEP71L7V1/W1	RYEP100L7V1/W1	RYEP125L7W1
NOMINAL CAPACITY (3)	Cooling	kW	7.10	10.00	12.20
	Heating	kW	8.00	11.00	14.50
NOMINAL INPUT	Cooling	kW	2.70/2.63	3.69/3.79	4.55
	Heating	kW	2.57/2.50	3.79/3.89	4.34
EER			2.63/2.70	2.71/2.64	2.68
COP			3.11/3.20	2.90/2.83	3.34
ENERGY LABEL	Cooling		D/D	D/D	D
	Heating		D/C	D/D	C
ANNUAL ENERGY CONSUMPTION	Cooling	kWh	1,350/1,315	1,845/1,895	2,275

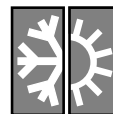

2 Specifications

2

TECHNICAL SPECIFICATIONS						
For indoor units only:						
INDOOR UNITS				FDYMP71L7V1	FDYMP100L7V1	FDYMP125L7V1
DIMENSIONS	Unit	H	mm	279		
		W	mm	987		1,387
		D	mm	750		
WEIGHT	Unit	kg		38.1		48.6
MATERIAL	Unit	Painted galvanised steel plate				
SOUND LEVEL	Sound pressure (cooling/heating) (1)	high	dB(A)	37/37	39/39	41/41
		low	dB(A)	33/33	34/34	35/35
	Sound power (cooling only) (2)	high	dB(A)	63	65	66
FAN	Air flow rate (cooling/heating)	high	m ³ /min	19/19	27/27	35/35
		low	m ³ /min	14/14	20/20	24/24
	Speed	steps		3 steps		
	Type	Sirocco fan				
	Qty x motor output	W		1 x 130	1 x 155	1 x 225
	External static pressure (H-L)	Pa		100 - 50		
	Drive	Direct drive				
HEAT EXCHANGER	Type	Fin rhombus type, ϕ 7 Hi-XA tube				
	Rows x stages x fin pitch	mm		3 x 14 x 1.75		
	Face area	m ²		0.226		0.344
AIR FILTER	Resin net					
TEMPERATURE CONTROL	Computerised control					
PIPING CONNECTIONS		liquid	mm	ϕ 9.52		
		gas	mm	ϕ 15.9	ϕ 19.1	
		drain	mm	I.D. ϕ 25	I.D. ϕ 25	I.D. ϕ 25
		drain	mm	O.D. ϕ 32	O.D. ϕ 32	O.D. ϕ 32
INSULATION MATERIAL	Heat insulation	Both liquid and gas pipes				
	Sound absorbing insulation	Felt				
For outdoor units	Pair application	See chapter RP-L7/B7/RYP-L7/RYP-L7				
	Twin application	See chapter RP-L7/B7/RYP-L7/RYP-L7				

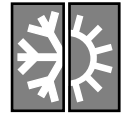

2 Specifications

2

ELECTRICAL SPECIFICATIONS						
For indoor units only:				FDYMP71L7V1	FDYMP100L7V1	FDYMP125L7V1
CURRENT	Nominal running current	cooling/heating	A	See chapter RP-L7/B7/RYP-L7/RYEP-L7		
	Max. running current	cooling/heating	A	See chapter RP-L7/B7/RYP-L7/RYEP-L7		
For combination indoor units + outdoor units:				FDYMP71L7V1	FDYMP100L7V1	FDYMP125L7V1
				RP71L7V1/W1-RP71B7T1	RP100L7V1/W1-RP100B7T1	RP125L7W1-RP125B7T1
CURRENT	Nominal running current	cooling	A	See chapter RP-L7/B7		
	Max. running current	cooling	A	See chapter RP-L7/B7		
	Starting current	cooling	A	See chapter RP-L7/B7		
For combination indoor units + outdoor units:				FDYMP71L7V1	FDYMP100L7V1	FDYMP125L7V1
				RYP71L7V1/W1	RYP100L7V1/W1	RYP125L7W1
CURRENT	Nominal running current	cooling/heating	A	See chapter RYP-L7		
	Max. running current	cooling/heating	A	See chapter RYP-L7		
	Starting current	cooling/heating	A	See chapter RYP-L7		
For combination indoor units + outdoor units:				FDYMP71L7V1	FDYMP100L7V1	FDYMP125L7V1
				RYEP71L7V1/W1	RYEP100L7V1/W1	RYEP125L7W1
CURRENT	Nominal running current	cooling/heating	A	See chapter RYEP-L7		
	Max. running current	cooling/heating	A	See chapter RYEP-L7		
	Starting current	cooling/heating	A	See chapter RYEP-L7		
For indoor units only:				FDYMP71L7V1	FDYMP100L7V1	FDYMP125L7V1
POWER SUPPLY				V1	V1	V1
NOMINAL DISTRIBUTION SYSTEM VOLTAGE	Phase		1~	1~	1~	1~
	Frequency	Hz	50	50	50	50
	Voltage	V	230	230	230	230

3TW25041-1
3TW25051-1
3TW25061-1

NOTES

- 1 Nominal cooling capacities are based on: indoor temperature 27°CDB/19°CWB * outdoor temperature 35°CDB * refrigerant piping length: 7.5m * level difference: 0m.
- 2 Nominal heating capacities are based on: indoor temperature: 20°CDB * outdoor temperature: 7°CDB/6°CWB * refrigerant piping length: 7.5m * level difference 0m.
- 3 Capacities are net, including a deduction for cooling (an addition for heating) for indoor fan motor heat.
- 4 The sound pressure level is measured via a microphone at 1.5m distance from the unit. It is a relative value, depending on the distance and acoustic environment. For measuring conditions: please refer to item 6 of this chapter.
- 5 The sound power level is an absolute value indicating the "power" which a sound source generates.
- 6 Energy label: scale from A (most efficient) to G (less efficient).
- 7 Annual energy consumption: based on average use of 500 running hours per year at full load (= nominal conditions).



3 Dimensional drawings

3

FDYMP71-100L7

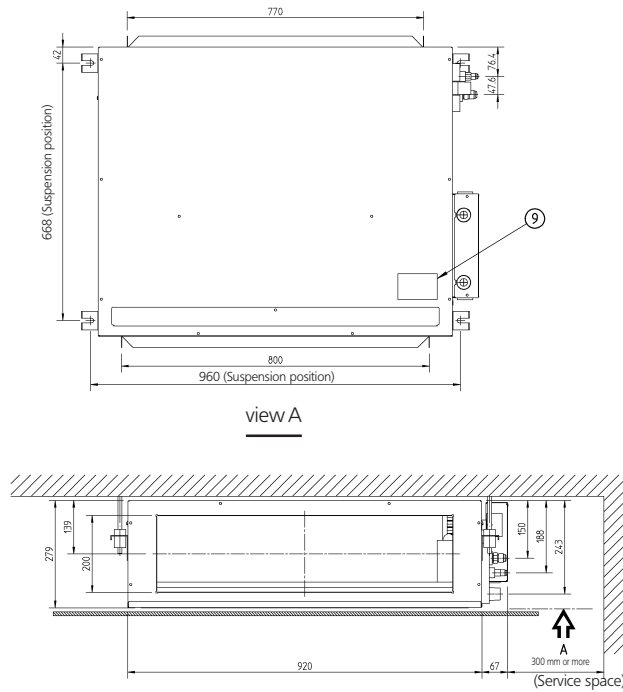

- 1 Liquid pipe connection ϕ 9.52 Flare connection
- 2 Gas pipe connection ϕ A Flare connection
- 3 Remote control wiring connection
- 4 Power supply connection
- 5 Drain pipe connection VP25 (O.D. ϕ 32, I.D. ϕ 25)
- 6 Air filter
- 7 Air suction side
- 8 Air discharge side
- 9 Name plate

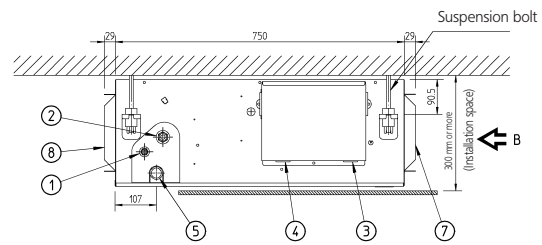
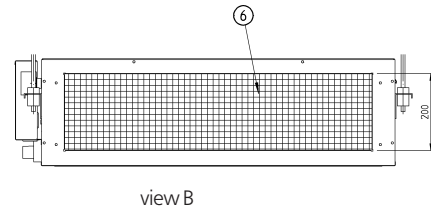

Notes:
 1. Refer to 'outlook drawing for installing optional accessories' when installing optional accessories.
 2. For maintenance of the air filter, it is necessary to provide a service access panel according to the installation method. (Refer to the 'filter installation method' drawing)

Model	A
FDYMP71L7V1	15.90
FDYMP100L7V1	19.10

3TW25044-1

FDYMP125L7

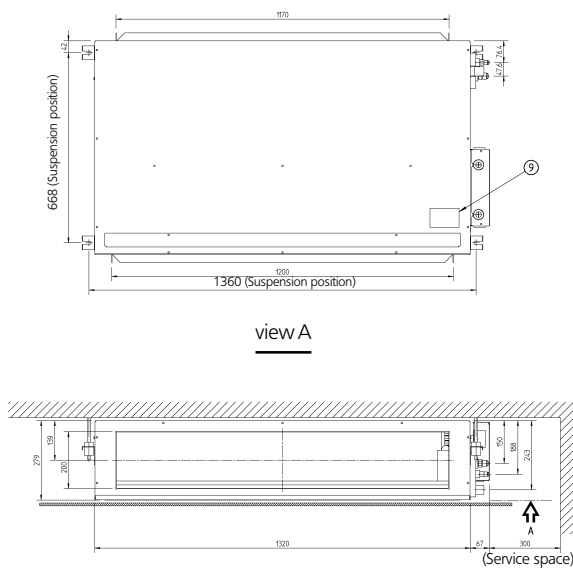

- 1 Liquid pipe connection ϕ 9.52 Flare connection
- 2 Gas pipe connection ϕ 19.10 Flare connection
- 3 Remote control wiring connection
- 4 Power supply connection
- 5 Drain pipe connection VP25 (O.D. ϕ 32, I.D. ϕ 25)
- 6 Air filter
- 7 Air suction side
- 8 Air discharge side
- 9 Name plate

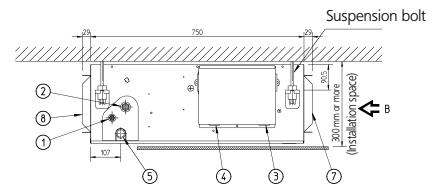

Notes:
 1. Refer to 'outlook drawing for installing optional accessories' when installing optional accessories.
 2. For maintenance of the air filter, it is necessary to provide a service access panel according to the installation method. (Refer to the 'filter installation method' drawing)

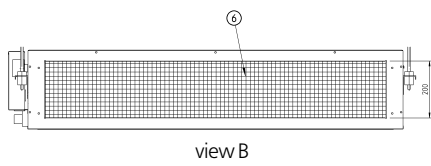

3TW25064-1

6



4 Piping diagrams

4

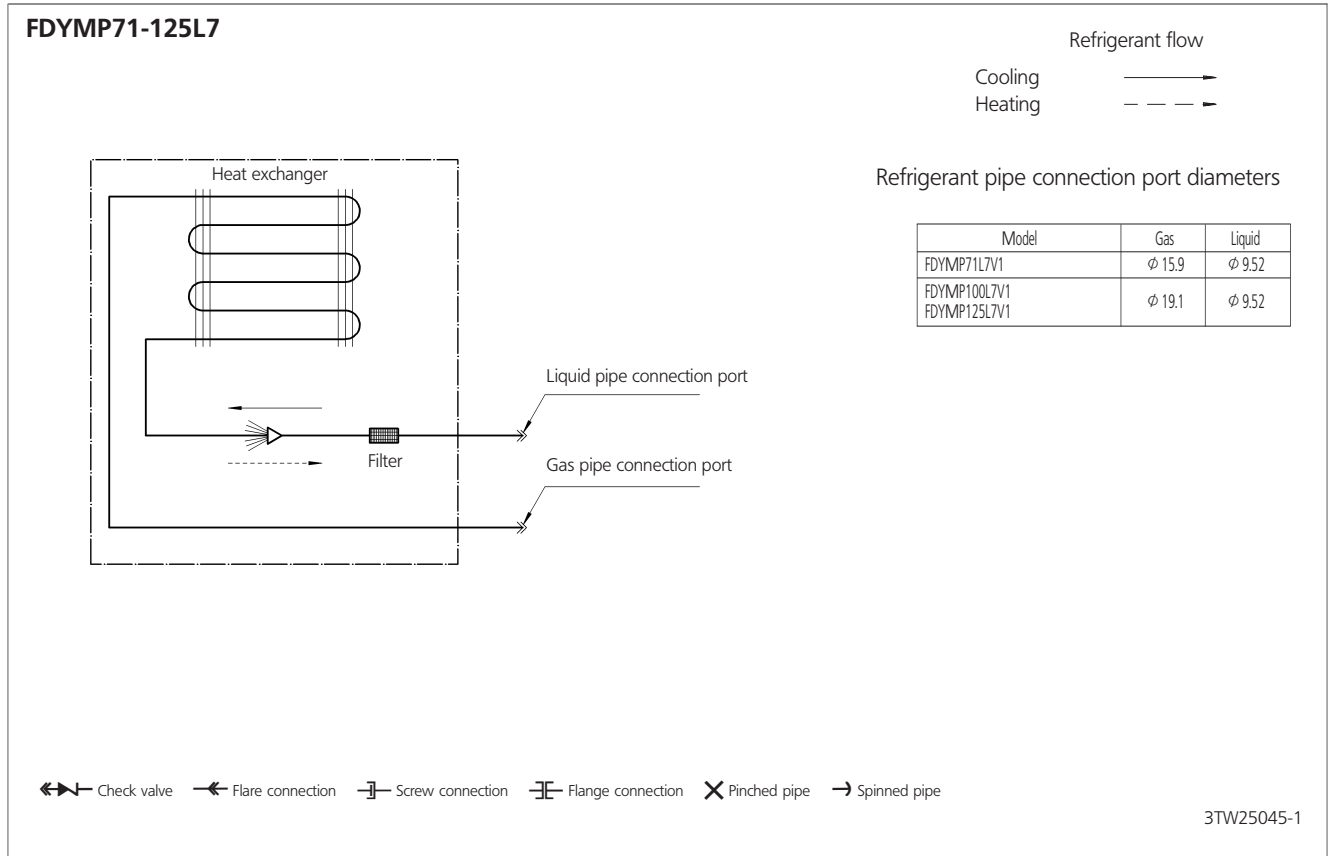



5 Wiring diagrams

5

FDYMP71~125L7

Notes

- When using the central remote control, see manual for connection to the unit.
- The infrared remote control model varies according to the combination system. See technical data and catalogs before connecting.

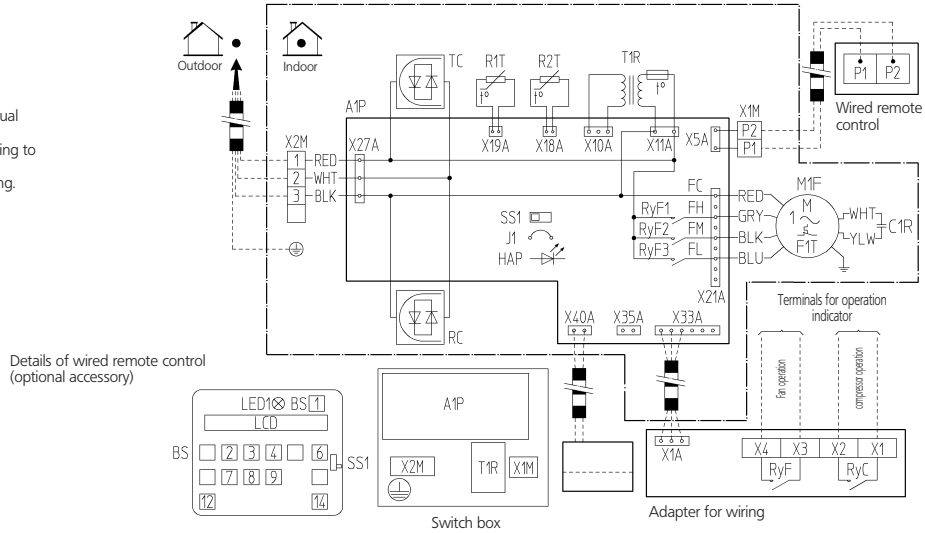

- Field wiring
- Terminal
- Connector
- Wire clamp
- Protective earth (screw)

Colours
 BLK: Black/ PPL: purple/ BLU: Blue/
 WHT: White/ RED: Red/ GRN: green/
 GRY: grey/ YLW: Yellow

- | | | | | | | |
|--------|---|----------------------|-----------------------------|----------------------|------------------------------|--|
| A1P | Printed circuit board | SS1 | Selector switch (emergency) | Wired remote control | LED1 | Light emitting diode (service monitor red) |
| T1R | Power supply transformer (transformer 220-240V/ 218V) | X1M | Terminal strip | BS1 | LCD | Liquid crystal display (LCD) |
| C1R | Capacitor (fan) | X2M | Terminal strip | BS2 | SS1 | Selector switch (main/sub) |
| F1T | Thermal fuse (152°C (M1F embedded)) | RC | Signal receiver circuit | BS3,BS8 | Adapter for wiring | |
| HAP | Light emitting diode (service monitor green) | TC | Signal transmission circuit | BS4,BS9 | RyC/RyF | Magnetic relay |
| M1F | Motor (fan) | Group control jumper | J1 | BS6 | Connector for optional parts | |
| R1T | Thermistor (air) | | | BS7 | X33A | Connector (adapter for wiring) |
| R2T | Thermistor (coil) | | | BS11 | X35A | Connector (group control adapter) |
| RyF1-3 | Magnetic relay (fan) | | | BS12 | X40A | Connector (remote ON/OFF forced OFF) |

Cautions for servicing

With the power on, troubles can be monitored on the remote controller or the LED on the PC board of the indoor unit.

Troubleshooting with the display on the liquid crystal of the remote controller.

When the operation stops due to trouble, the operation lamp flashes, " " and the error codes are indicated on the liquid crystal display. In this case, diagnose the fault contents by referring to the table on the right. In case of group control, the unit number is displayed so that the indoor unit with the trouble can be recognized (see note 2).

- Press the INSPECTION/TEST OPERATION button " " is displayed and "O" flashes.
- Press the PROGRAMMING TIME button and find the unit number which stopped due to trouble.
 Number of beeps:
 3 short beeps ... Perform all the following operations
 1 short beep ... Perform ③ and ⑥
 1 long beep ... No trouble
- Press the operation mode selector button and upper figure of the error code flashes.
- Continue pressing the PROGRAMMING TIME button until it makes 2 short beeps and find the upper code.
- Press the OPERATION SELECTOR button and lower figure of the error code flashes.
- Continue pressing the PROGRAMMING TIME button until it makes a long beep and find the lower code. A long beep indicates the error code.

Error codes	Malfunction	Remarks
A1	Indoor unit's PC board	
A6	Indoor fan motor overloaded, overcurrent or locked	
AJ	Type set error (indoor unit)	Capacity data is wrongly preset or there is nothing programmed in the data hold IC.
C4	Sensor for heat exchanger temperature (indoor)	
C9	Sensor for suction air temperature (indoor)	
CJ	Sensor for remote controller	The remote controller thermistor does not work, but the system thermo run is possible.
E0	Action of safety device (outdoor unit)	
E1	Outdoor unit's PC board	
E3	Abnormal high pressure (outdoor unit)	
E4	Abnormal low pressure (outdoor unit)	
E9	Electronic expansion valve (outdoor unit)	
F3	Abnormal discharge pipe temperature (outdoor unit)	
H3	High pressure switch defect (outdoor unit)	
H4	Low pressure switch defect (outdoor unit)	
H9	Outdoor air thermistor	(See note 3)
J3	Discharge pipe thermistor (outdoor unit)	
J5	Suction pipe thermistor (outdoor unit)	
J6	Heat exchanger thermistor (outdoor unit)	(See note 3)
PJ	Type set error (outdoor unit)	Capacity data is wrongly preset or there is nothing programmed in the data hold IC.
U0	Abnormal suction pipe temperature (outdoor unit)	
U1	Reverse phase	Reverse 2 of the 3 lead wires
U4	Transmission error (indoor unit - outdoor unit)	Transmission indoor - outdoor is improper
U5	Transmission error (indoor unit - remote controller)	Transmission indoor-remote cont. Is improper if group control: check "master-slave jumper".
UF	Miss wiring	Field wiring is not correct

For the white error codes on a black background, be sure to check and repair, though system may be operated without displaying " ".

Notes:

- Press the INSPECTION / TEST OPERATION button. " " starts flashing.
- Keep down the ON/OFF button for 5 seconds or longer in the inspection mode, and the above trouble history disappears, after the trouble code goes on and off twice, followed by the code "00" (normal). The display changes from the inspection mode to the normal mode.
- Equipment operation in response to errors will vary according to the model.

Troubleshooting with the LED on the indoor PC board.

The following checking can be made with the service monitor LED (green) (normal when flashing).

LED on ● LED off ✨ LED flashing

Microcomputer normal monitor	Description
HAP	
✨	Normal -> Outdoor unit
✨	Indoor PC board error (see note)
●	Power supply trouble or PC board error (see note)

NOTE:

Cut off the power and wait for 5 seconds or longer. Turn on the power again and see if the LED is the same state.

2TW25046-1A



6 Sound level

6-1 Sound level data

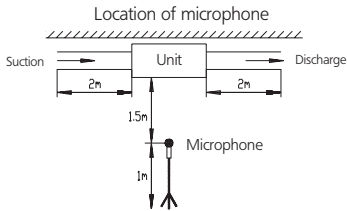

6
6-1

Model	Sound pressure level		Measuring location 	Sound power level (H) (cooling)
	230V, 50Hz			
	Cooling/Heating			
	High	Low		
FDYMP71L7V1	37/37	33/33		63
FDYMP100L7V1	39/39	34/34		65
FDYMP125L7V1	41/41	35/35		66

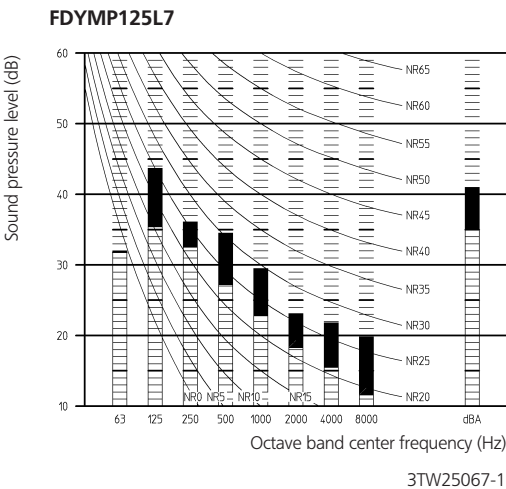
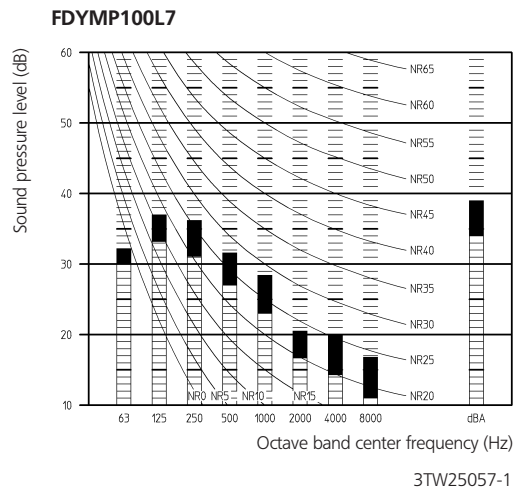
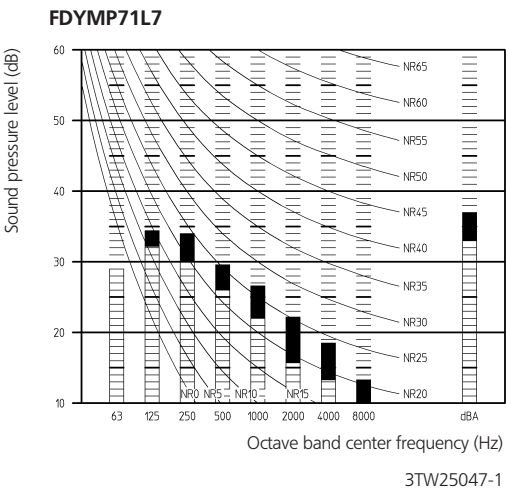
6-2 Sound pressure spectrum



Legend

-  High speed
-  Low speed

NOTES

- 1 Data is valid at free field condition
- 2 Data is valid at low ESP operation condition. (50 Pa AT 230V)
- 3 dBA = A-weighted sound pressure level (A-scale according to IEC)
- 4 Reference acoustic pressure 0dB = 20μPa



6 Sound level

6-3 Sound power spectrum

6

6-3

FDYMP71L7

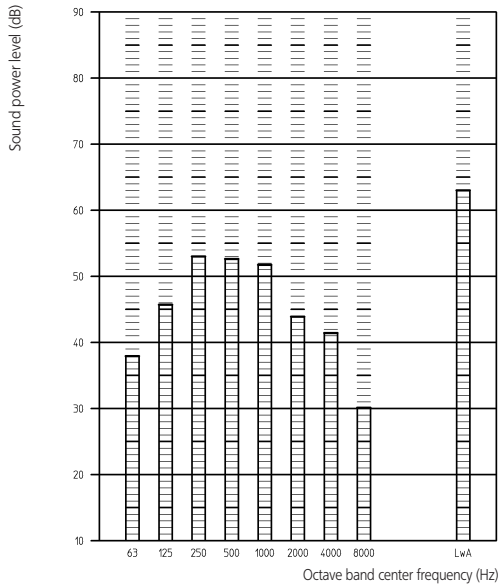

3TW25047-2

FDYMP100L7

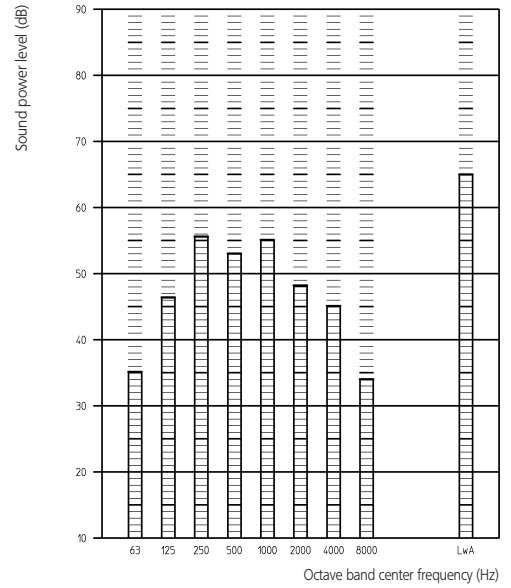

3TW25057-2

FDYMP125L7

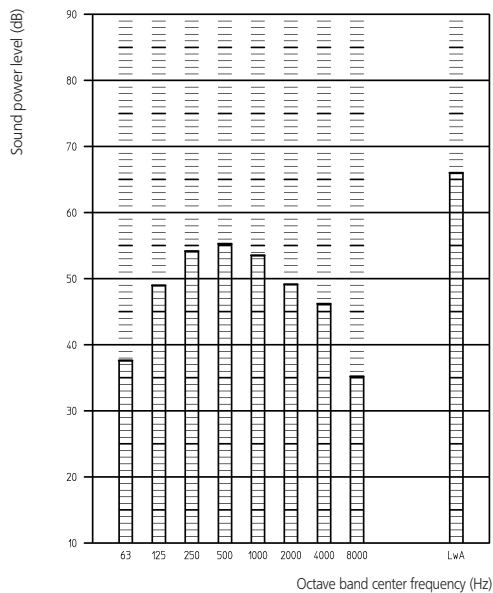

3TW25067-2

NOTES

- 1 Data is valid at low ESP operation high tap condition. (50Pa at 230V)
- 2 dB(A) = A-weighted sound power level (A-scale according to IEC)
- 3 Measured in duct according to ISO 9614

7 Fan characteristics



FDYMP71L7

Fan curve 71 class motor

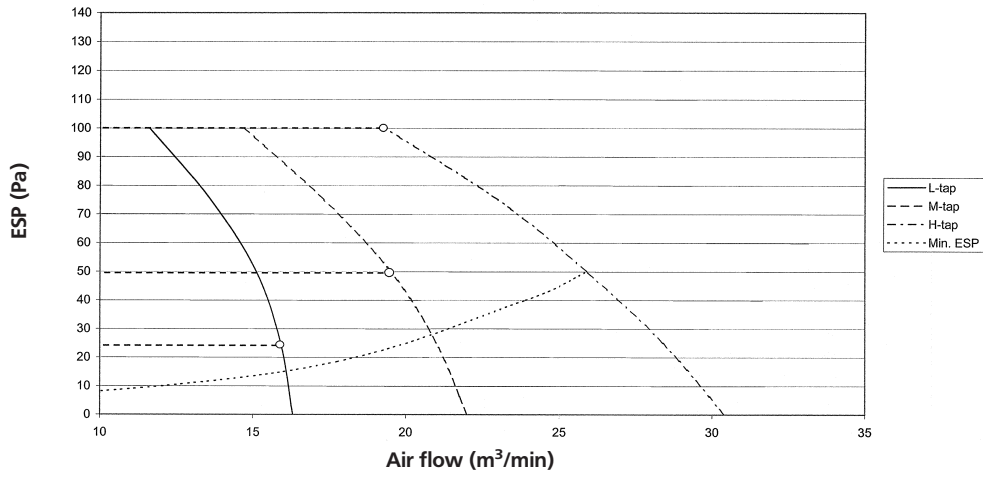

3TW25048-1

FDYMP100L7

Fan curve 100 class motor

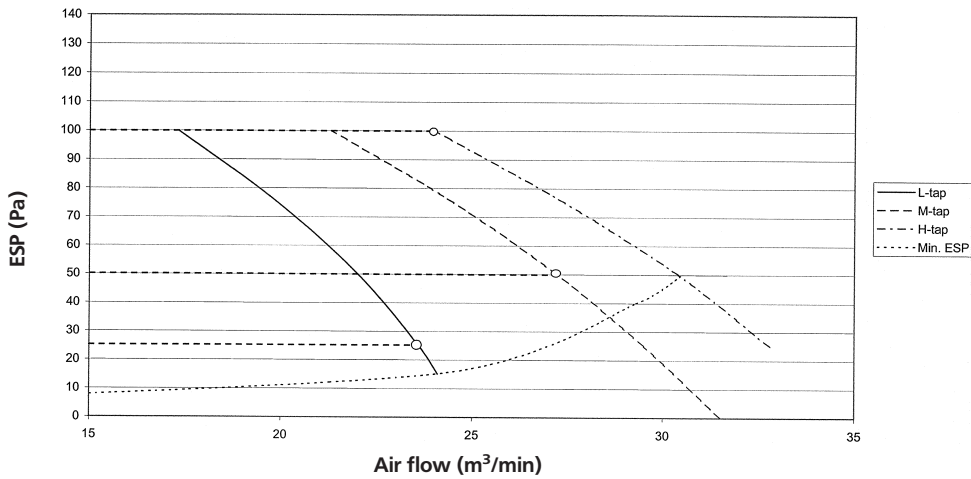

3TW25058-1

FDYMP125L7

Fan curve 125 class motor

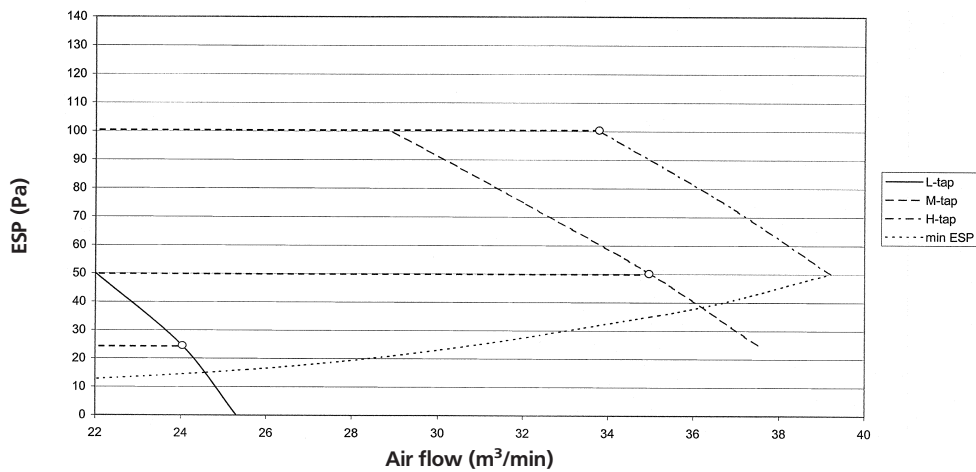

3TW25068-1



8 Accessories

8-1 Optional accessories

8
8-1

Item	Wired type	71-100-125 Class
Remote control		BRC1D517
Adapter for wiring (interlock for fresh air intake fan)		KRP1B59
Adaptor for external ON/OFF and monitoring		KRP4A51
Wiring adapte (electrical heater and hour meter		EKRP1B2
Installation box		KRP1B947A
Remote ON/OFF, forced OFF		EKR0R0

3TW25049-4B

* Electrical heater and humidifier are field supply. The electrical heater should be installed in the discharge duct.

Wire specifications

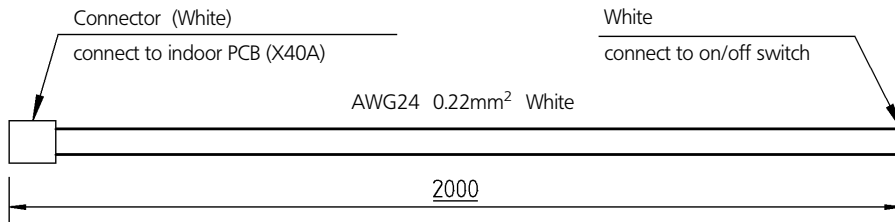

Operating method

Input	Switch	ON*	
		OFF	
Remote control	ON		
	OFF		
Unit	Standard setting: 'forced off'	ON	
		OFF	
Alternative setting: 'on/off'	ON		
	OFF		

* Input 'ON' = closed contact.

Forced off	On/off operation
Input 'on' stops operation + disables control	Input off→on: starts operation, remote control is still enabled.
Input 'off' enables control	Input on→off: stops operation, remote control is still enabled.

Selection of 'FORCED OFF' and 'ON/OFF' operation

Setting	Mode NO	First code NO	Second code NO
Forced off	12 (22)	1	01
On/off operation			02

4TW23941-1

9 Control systems

9-1 Wired remote control



BRC1D527

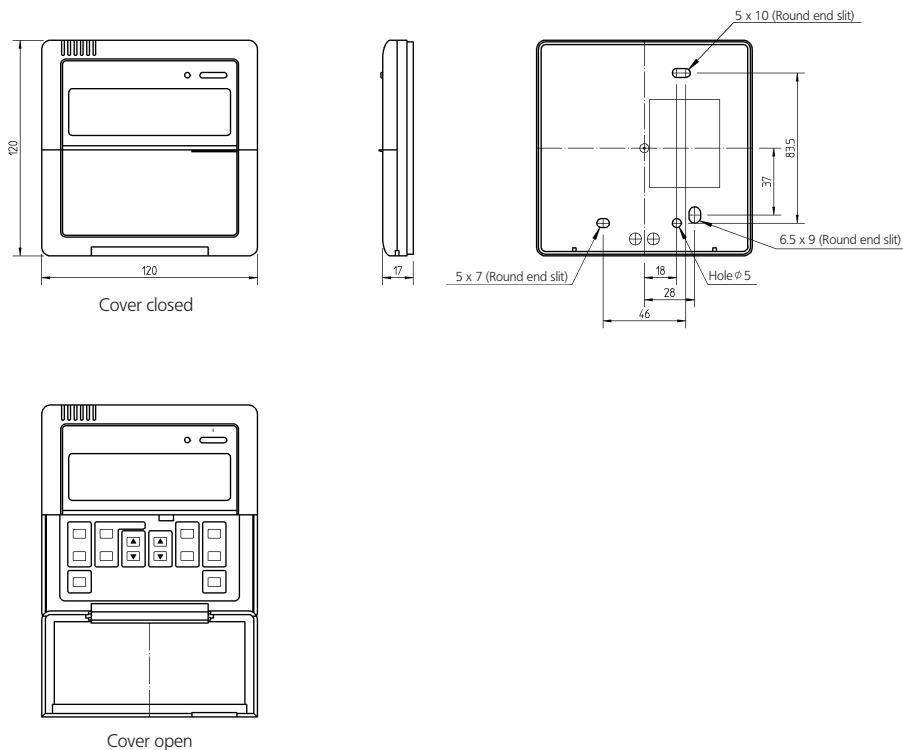

3TW23651-2



10 Center of gravity

10 FDYMP71-125L7

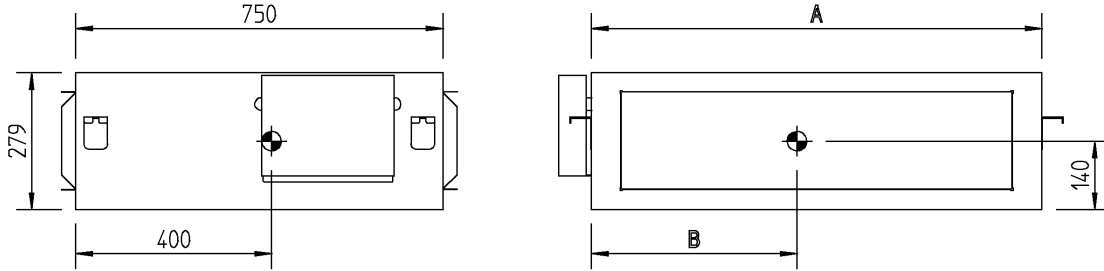

Model	A	B
71 - 100 Class	920	420
125 Class	1320	600

4TW25049-3

11 Safety device settings

FDYMP71-125L7

Model	Safety devices	71	100	125
FDYMP	Fan motor thermal fuse (°C)	152±2	152±2	152±2

3TW21009-2C

12 Installation instructions



DAIKIN

DAIKIN

<p>Preparations before installing</p>	<p>Selecting installation site</p>	<p>Drain pipe work</p>	
<p>Names and functions of parts</p>	<p>How to clean the air filter</p>	<p>Drain pipe work</p> <p>Computerised control (forced OFF and ON/OFF operation)</p>	
<p>Service of switch box</p>		<p>Refrigerant piping work</p> <p>Indoor unit installation</p>	

1TW25049-2

12 Installation instructions



12

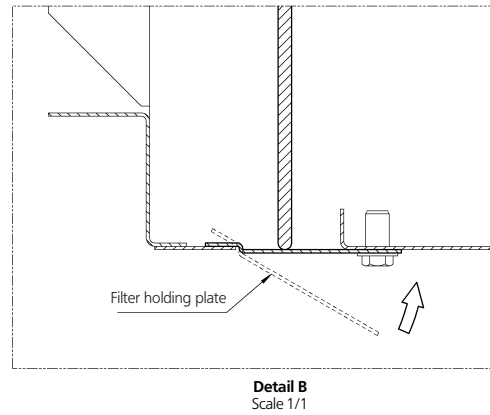
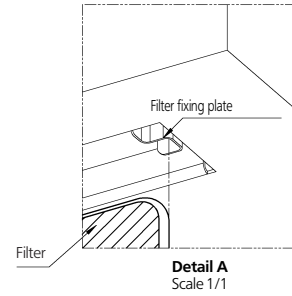
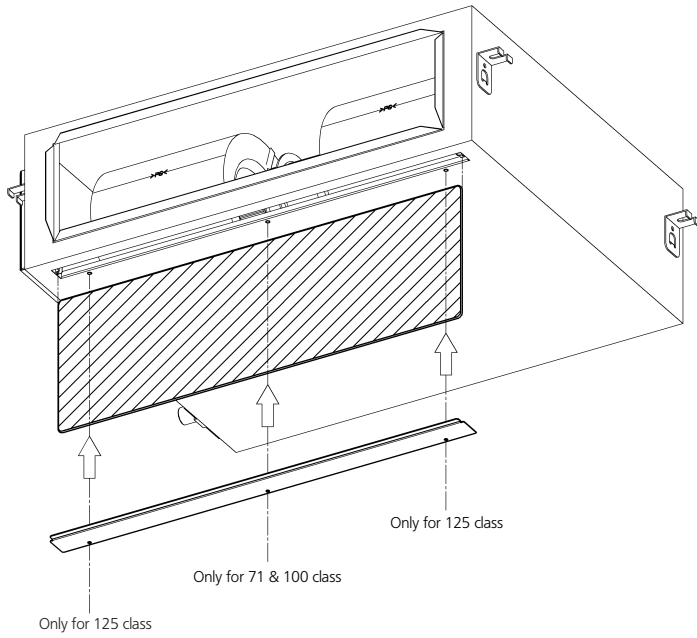

3TW25044-2

NOTES

- 1 Filter must slide in the filter fixing plates (see detail A)
- 2 Filter holding plate must be mounted correct (see detail B)