

DAIKIN



INSTALLATION AND OPERATION MANUAL

Split System air conditioners

FDYMP71L7V1
FDYMP100L7V1
FDYMP125L7V1

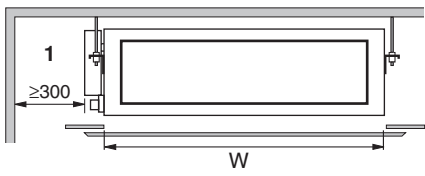

1

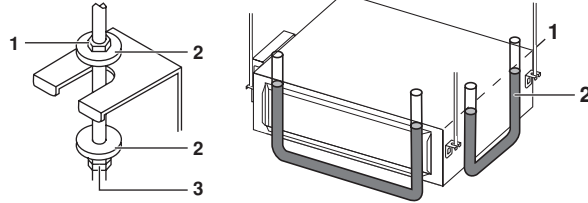

2

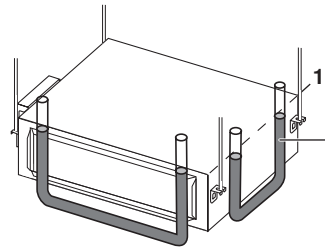

3

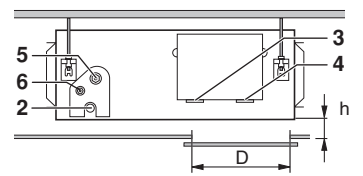

4

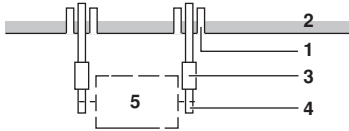

5

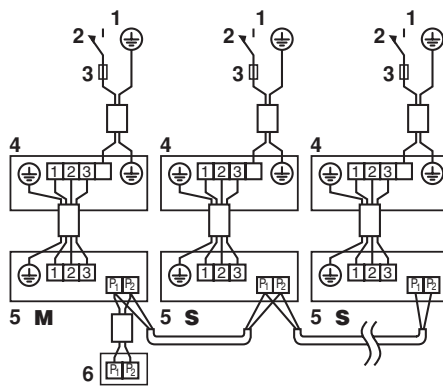

7

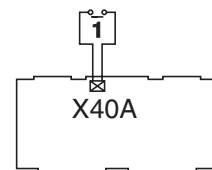

8

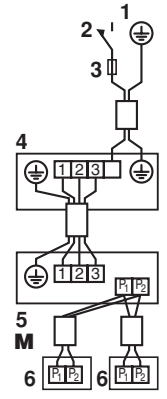

9

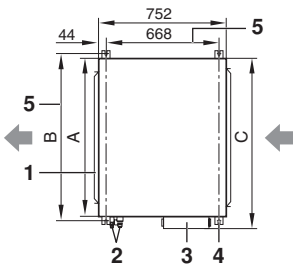

6

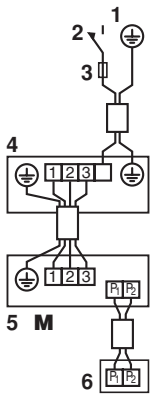

10

| ❄️ | 🏠 | | 🏠 | |
|------------|-------|-------|------|--------|
| | °C | | 💧 | °C |
| RP71~125 | °C DB | 18-35 | ≤80% | -15-46 |
| | °C WB | 14-25 | | |
| RYP71~125 | °C DB | 18-35 | ≤80% | -5-46 |
| | °C WB | 12-25 | | |
| RYEP71~125 | °C DB | 18-35 | | 10-43 |
| | °C WB | 12-25 | | |

| ☀️ | 🏠 | | 🏠 | |
|------------|-------|-------|-------|--------|
| | °C | | °C | |
| RYP71~125 | °C DB | 15-24 | °C DB | -9-21 |
| | °C WB | | °C WB | -10-15 |
| RYEP71~125 | °C DB | 15-24 | °C DB | -9-21 |
| | °C WB | | °C WB | -10-15 |

11

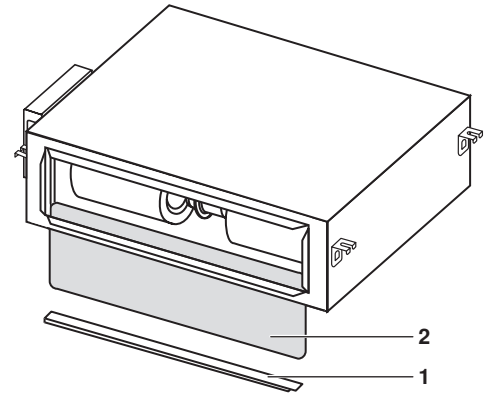

12

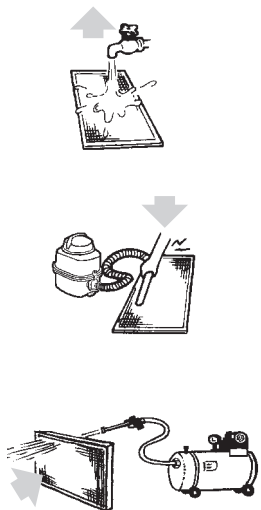

13

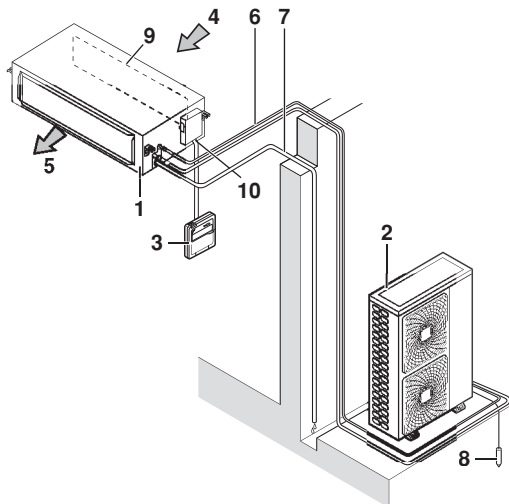

14

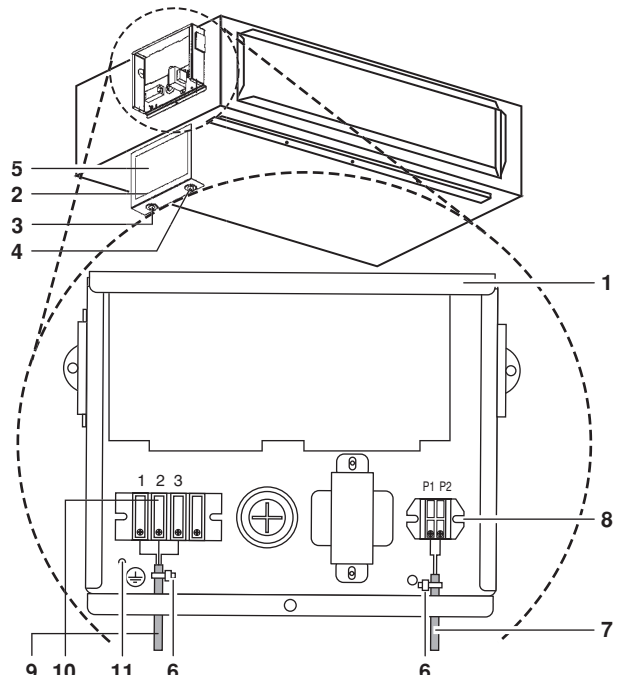

15

Daikin Europe N.V.

declares under its sole responsibility that the air conditioning models to which this declaration relates:
erklärt auf seine alleinige Verantwortung daß die Modelle der Klimageräte für die diese Erklärung bestimmt ist:
déclare sous sa seule responsabilité que les appareils d'air conditionné visés par la présente déclaration:

verklaart hierbij op eigen exclusieve verantwoordelijkheid dat de airconditioning units waarop deze verklaring betrekking heeft:
declara baja su única responsabilidad que los modelos de aire acondicionado a los cuales hace referencia la declaración:
dichiara sotto sua responsabilità che i condizionatori modello a cui è riferita questa dichiarazione:

δηλώνει με αποκλειστική της ευθύνη ότι τα μοντέλα των κλιματιστικών συσκευών στα οποία αναφέρεται η παρούσα δήλωση:
declara sob sua exclusiva responsabilidade que os modelos de ar condicionado a que esta declaração se refere:
erklærer under eneansvar, at klimateknologimodellerne, som denne deklaration vedrører:

deklarerar i egenskap av huvudansvarig, att luftkonditioneringsmodellerna som berörs av denna deklaration innebär att:
erklærer et fullstendig ansvar for at de luftkondisjoneringsmodeller som berøres av denne deklarasjon innebærer at:
ilmoittaa yksinomaan omalla vastuullaan, että tämän ilmoituksen tarkoitamat ilmastointilaitteiden mallit:

FDYMP71L7V1, FDYMP100L7V1, FDYMP125L7V1

are in conformity with the following standard(s) or other normative document(s), provided that these are used in accordance with our instructions:
der/den folgenden Norm(en) oder einem anderen Normdokument oder -dokumenten entspricht/entsprechen, unter der Voraussetzung, daß sie gemäß unseren Anweisungen eingesetzt werden:
sont conformes à la/aux norme(s) ou autre(s) document(s) normatif(s), pour autant qu'ils soient utilisés conformément à nos instructions:

conform de volgende norm(en) of één of meer andere bindende documenten zijn, op voorwaarde dat ze worden gebruikt overeenkomstig onze instructies:
están en conformidad con la(s) siguiente(s) norma(s) u otro(s) documento(s) normativo(s), siempre que sean utilizados de acuerdo con nuestras instrucciones:
sono conformi al(i) seguente(i) standard(s) o altro(i) documento(i) a carattere normativo, a patto che vengano usati in conformità alle nostre istruzioni:

είναι σύμφωνα με το(α) ακόλουθο(α) πρότυπο(α) ή άλλο έγγραφο(α) κανονισμών, υπό την προϋπόθεση ότι χρησιμοποιούνται σύμφωνα με τις οδηγίες μας:
estão em conformidade com a(s) seguinte(s) norma(s) ou outro(s) documento(s) normativo(s), desde que estes sejam utilizados de acordo com as nossas instruções:
overholder følgende standard(er) eller andet/andre retningsgivende dokument(er), forudsat at disse anvendes i henhold til vore instrukser:

respektive utrustning är utförd i överensstämmelse med och följer följande standard(er) eller andra normgivande dokument, under förutsättning att användning sker i överensstämmelse med våra instruktioner:
respektive utstyr er i overensstemmelse med følgende standard(er) eller andre normgivende dokument(er), under forutsetning av at disse brukes i henhold til våre instrukser:
vastaavat seuraavien standardien ja muiden ohjeellisten dokumenttien vaatimuksia edellyttäen, että niitä käytetään ohjeidemme mukaisesti:

EN60335-2-40,

following the provisions of:
gemäß den Vorschriften der:
conformément aux stipulations des:
overeenkomstig de bepalingen van:
siguiendo las disposiciones de:
secondo le prescrizioni per:

με τήρηση των διατάξεων των:
de acordo com o previsto em:
under iagttagelse af bestemmelserne i:
enligt villkoren i:
gitt i henhold til bestemmelsene i:
noudattaen määräyksiä:

Low Voltage 73/23/EEC
Machinery Safety 98/37/EEC
Electromagnetic Compatibility 89/336/EEC *

Directives, as amended.
Direktiven, gemäß Änderung.
Directives, telles que modifiées.
Richtlijnen, zoals geamendeerd.
Directivas, según lo enmendado.
Direttive, come da modifica.
Οδηγιών, όπως έχουν τροποποιηθεί.
Directivas, conforme alteração em.
Direktiver, med senere ændringer.
Direktiv, med företagna ändringar.
Direktiver, med foretatte ændringer.
Direktivejä, sellaisina kuin ne ovat muutettuina.

* Note as set out in the Technical Construction File **DAIKIN.TCF.016** and judged positively by **KEMA** according to the **Certificate 81728-KRQ/EMC98-4341**.
Hinweis wie in der Technischen Konstruktionsakte **DAIKIN.TCF.016** aufgeführt und von **KEMA** positiv ausgezeichnet gemäß **Zertifikat 81728-KRQ/EMC98-4341**.
Remarque tel que stipulé dans le Fichier de Construction Technique **DAIKIN.TCF.016** et jugé positivement par **KEMA** conformément au **Certificat 81728-KRQ/EMC98-4341**.
Bemerk zoals vermeld in het Technisch Constructiedossier **DAIKIN.TCF.016** en in orde bevonden door **KEMA** overeenkomstig **Certificaat 81728-KRQ/EMC98-4341**.
Nota tal como se expone en el Archivo de Construcción Técnica **DAIKIN.TCF.016** y juzgado positivamente por **KEMA** según el **Certificado 81728-KRQ/EMC98-4341**.
Nota delineato nel File Tecnico di Costruzione **DAIKIN.TCF.016** e giudicato positivamente da **KEMA** secondo il **Certificato 81728-KRQ/EMC98-4341**.
Σημείωση όπως προσδιορίζεται στο Αρχείο Τεχνικής Κατασκευής **DAIKIN.TCF.016** και κρίνεται θετικά από το **KEMA** σύμφωνα με το **Πιστοποιητικό 81728-KRQ/EMC98-4341**.
Nota tal como estabelecido no Ficheiro Técnico de Construção **DAIKIN.TCF.016** e com o parecer positivo de **KEMA** de acordo com o **Certificado 81728-KRQ/EMC98-4341**.
Bemærk som anført i den Tekniske Konstruktionsfil **DAIKIN.TCF.016** og positivt vurderet af **KEMA** i henhold til **Certifikat 81728-KRQ/EMC98-4341**.
Information utrustningen är utförd i enlighet med den Tekniska Konstruktionsfilen **DAIKIN.TCF.016** som positivt intygas av **KEMA** vilket också framgår av **Certifikat 81728-KRQ/EMC98-4341**.
Merk som det fremkommer i den Tekniske Konstruktionsfilen **DAIKIN.TCF.016** og gjennom positiv bedømmelse av **KEMA** ifølge **Sertifikat 81728-KRQ/EMC98-4341**.
Huom jotta on esitetty Teknisessä Asiakirjassa **DAIKIN.TCF.016** ja jotta **KEMA** on hyväksynyt **Sertifikaatin 81728-KRQ/EMC98-4341** mukaisesti.



DAIKIN EUROPE NV
Zandvoordestraat 300, B-8400 Oostende, Belgium

CONTENTS

| | Page |
|---|----------|
| Installing the unit | 1 |
| Before installation | 1 |
| Selecting installation site | 2 |
| Preparations before installation | 2 |
| Indoor unit installation | 3 |
| Refrigerant piping work | 3 |
| Drain piping work | 3 |
| Electric wiring work | 4 |
| Wiring example and how to set the remote controller | 4 |
| Wiring example | 4 |
| Field setting | 5 |
| Test operation | 5 |
| | |
| Operating the unit | 6 |
| Names and functions of parts | 6 |
| Operation range | 6 |
| Operation procedure | 6 |
| Optimum operation | 6 |
| Not a malfunction of the air conditioner | 7 |
| Troubleshooting | 7 |
| Maintenance | 8 |



THANK YOU FOR PURCHASING THIS DAIKIN AIR CONDITIONER. CAREFULLY READ THE CHAPTER "OPERATING THE UNIT" ON PAGE 6 BEFORE USING THE AIR CONDITIONER. IT WILL TELL YOU HOW TO USE THE UNIT PROPERLY AND HELP YOU IF ANY TROUBLE OCCURS. AFTER READING THE MANUAL, FILE IT AWAY FOR FUTURE REFERENCE.

INSTALLING THE UNIT



READ THESE INSTRUCTIONS CAREFULLY BEFORE INSTALLATION.

IMPROPER INSTALLATION OR ATTACHMENT OF EQUIPMENT OR ACCESSORIES COULD RESULT IN ELECTRIC SHOCK, SHORT-CIRCUIT, LEAKS, FIRE OR OTHER DAMAGE TO THE EQUIPMENT. BE SURE ONLY TO USE ACCESSORIES MADE BY DAIKIN WHICH ARE SPECIFICALLY DESIGNED FOR USE WITH THE EQUIPMENT AND HAVE THEM INSTALLED BY A PROFESSIONAL.

IF UNCERTAINTY ARISES ABOUT THE INSTALLATION PROCEDURES OR USE, ALWAYS CONTACT YOUR DAIKIN DEALER FOR ADVICE AND INFORMATION.

BEFORE INSTALLATION

- Leave the unit inside its packaging until you reach the installation site. Where unpacking is unavoidable, use a sling of soft material or protective plates together with a rope when lifting, this to avoid damage or scratches to the unit.
- Refer to the installation manual of the outdoor unit for items not described in this manual.

Precautions

- Do not install or operate the unit in rooms mentioned below.
 - Places with mineral oil, or filled with oil vapour or spray like in kitchens. (Plastic parts may deteriorate.)
 - Where corrosive gas like sulphurous gas exists. (Copper tubing and brazed spots may corrode.)
 - Where volatile flammable gas like thinner or gasoline is used.
 - Where machines generating electromagnetic waves can be found. (Control system may malfunction.)
 - Where the air contains high levels of salt such as air near the ocean and where voltage fluctuates a lot (e.g. in factories). Also in vehicles or vessels.
- Do not install accessories on the casing directly. Drilling holes in the casing may damage electrical wires and consequently cause fire.

Optional accessories

Refer to catalogues and technical literature for selecting the remote controller, and install it in an appropriate place.

For the following items, take special care during construction and check after installation is finished

| Tick ✓ when checked | |
|--------------------------|--|
| <input type="checkbox"/> | Is the indoor unit fixed firmly? The unit may drop, vibrate or make noise. |
| <input type="checkbox"/> | Is the gas leak test finished? It may result in insufficient cooling. |
| <input type="checkbox"/> | Is the unit fully insulated? Condensate water may drip. |
| <input type="checkbox"/> | Does drainage flow smoothly? Condensate water may drip. |
| <input type="checkbox"/> | Does the power supply voltage correspond to that shown on the name plate? The unit may malfunction or components may burn out. |
| <input type="checkbox"/> | Are wiring and piping correct? The unit may malfunction or components may burn out. |
| <input type="checkbox"/> | Is the unit safely grounded? Dangerous at electric leakage. |
| <input type="checkbox"/> | Is the wiring size according to specifications? The unit may malfunction or components may burn out. |
| <input type="checkbox"/> | Is nothing blocking the air outlet or inlet of either the indoor or outdoor units? It may result in insufficient cooling. |
| <input type="checkbox"/> | Are refrigerant piping length and additional refrigerant charge noted down? The refrigerant charge in the system might not be clear. This to avoid confusion for future maintenance and serving of the installation. |

Notes to the installer

- Be sure to instruct the customer how to properly operate the system and show him/her the enclosed operation manual.

SELECTING INSTALLATION SITE (See figure 1 and 4)

- Select an installation site where the following conditions are fulfilled and that meets your customer's approval.
 - Where optimum air distribution can be ensured.
 - Where nothing blocks air passage.
 - Where condensate water can be properly drained.
 - Where the false ceiling is not noticeably on an incline.
 - Where sufficient clearance for maintenance and service can be ensured.
 - Where piping between indoor and outdoor units is possible within the allowable limit. (Refer to the installation manual of the outdoor unit.)
 - Keep indoor unit, outdoor unit, power supply wiring and transmission wiring at least 1 meter away from televisions and radios. This is to prevent image interference and noise interference in those electrical appliances.
(Electric noise may be generated depending on the conditions under which the electric wave is generated, even if 1 meter is kept.)
 - Never place anything under the indoor unit that you don't want to get wet. The unit may sweat when the humidity is over 80% or when the drain outlet is clogged.
 - Never place other heating equipment directly beneath the indoor unit. Subject to deformation caused by heat.
 - The unit should be installed at least 2.5 m from the floor.

- Use suspension bolts for installation. Check whether the ceiling is strong enough to support the weight of the indoor unit. If there is a risk, reinforce the ceiling before installing the unit.

- Service space ≥ 300
- Drain pipe
- Power supply wiring port
- Transmission wiring port
- Gas pipe
- Liquid pipe

PREPARATIONS BEFORE INSTALLATION

- Suspension bolt position. (See figure 6)

| Model | A | B | C |
|-------------|------|------|------|
| FDYMP71•100 | 920 | 960 | 990 |
| FDYMP125 | 1320 | 1360 | 1390 |

- Indoor unit
- Pipe
- Switch box
- Suspension bolt (x4)
- Suspension bolt pitch distance

For other installation than standard installation, contact your Daikin dealer for details.

- The fan speed for this indoor unit is preset to provide high external static pressure.

If lower external static pressure is required, reset the external static pressure by changing the initial setting from the remote controller.

Refer to "Setting of static pressure" on page 5.

- Install the suspension bolts.

(Use M10 size bolt for the suspension bolt.) Use anchors for existing ceilings, and a sunken insert, sunken anchors or other field supplied parts for new ceilings to reinforce the ceiling in order to bear the weight of the unit.

Installation example (See figure 5)

- Anchor
- Ceiling slab
- Long nut or turn-buckle
- Suspension bolt
- Indoor unit

NOTE All the above parts are field supplied.



INDOOR UNIT INSTALLATION

When installing optional accessories read also the installation manual of the optional accessories. Depending on the field conditions, it may be easier to install optional accessories before the indoor unit is installed.

1. Install the indoor unit temporarily.

- Attach the hanger bracket to the suspension bolt. Be sure to fix it securely by using a nut and washer from the upper and lower sides of the hanger bracket. (See figure 2)

- Nut (field supply)
- Washer for hanger bracket (field supply)
- Tighten (double nut)

2. Check if the unit is horizontally levelled.

- If the unit is tilted against condensate flow, condensate water could drip out of the unit.
- Check if the unit is levelled at all four corners with a water level or a water-filled vinyl tube as shown in figure 3.

- Water level
- Vinyl tube

3. Tighten the upper nut.

NOTE Required service opening dimensions for air filter maintenance (See figure 1 and figure 4)

- W Width of service opening
D Depth of service opening
h Distance unit-false ceiling

| Model | W | D |
|-------------|-------|-----------------|
| FDYMP71•100 | ≥920 | If h≤30 ⇒ D≥100 |
| FDYMP125 | ≥1320 | If h>30 ⇒ D≥200 |

REFRIGERANT PIPING WORK

For refrigerant piping of outdoor unit, refer to the installation manual supplied with the outdoor unit.

NOTE All field piping must be provided by a licensed refrigeration technician and must comply with the relevant local and national codes.

- Use a pipe cutter and flare suitable for the used refrigerant.
- Apply ether oil or ester oil around the flare portions before connecting.
- To prevent dust, moisture or other foreign matter from infiltrating the tube, either pinch the end, or cover it with tape.
- The outdoor unit is charged with refrigerant.
- Be sure to use both a spanner and torque wrench together when connecting or disconnecting pipes to/from the unit.

- Torque wrench
- Spanner
- Piping union
- Flare nut

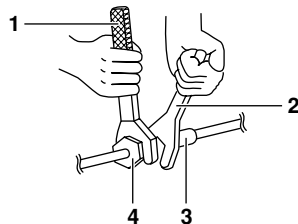

- Refer to Table 1 for the dimensions of flare nut spaces and the appropriate tightening torque. (Overtightening may damage the flare and cause leaks.)

Table 1

| Pipe gauge | Tightening torque | Flare dimension A (mm) | Flare shape |
|------------|-------------------------------------|------------------------|-------------|
| Ø9.5 | 32.7~39.9 N•m (333~407 kgf•cm) | 12.0~12.4 | |
| Ø15.9 | 61.8~75.4 N•m (630~770 kgf•cm) | 18.6~19.0 | |
| Ø19.1 | 97.2~118.6 N•m (990~1210 kgf•cm) | 22.9~23.3 | |

- When connecting the flare nut, coat the flare both inside and outside with ether oil or ester oil and initially tighten by hand before tightening firmly.

Coat here with ether oil or ester oil

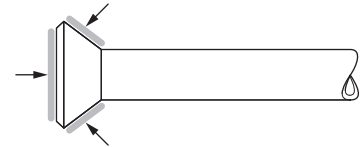

- Check the pipe connector for gas leaks, then insulate it.

- Liquid pipe
- Gas pipe
- Insulation for fitting of liquid line (field supply). The insulation should withstand 80°C.
- Insulation for fitting of gas line (field supply). The insulation should withstand 120°C.
- Clamps (use 2 clamps per insulation)

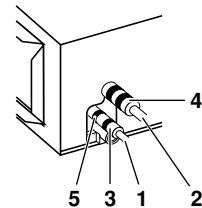

DRAIN PIPING WORK

1. Install the drain pipes.

- Keep piping as short as possible and slope it downwards so that air may not remain trapped inside the pipe.
- Keep pipe size equal to or greater than that of the connecting pipe.
- For connection to the drain socket: use a flexible hose (field supply) and clamp it firmly. This to avoid leaks due to operating vibration of the unit.
- After clamping, isolate the drain socket. This is to avoid leaks due to sweating of the unit.

- Metal clamp
- Flexible hose
- Insulation
- Plastic clamp

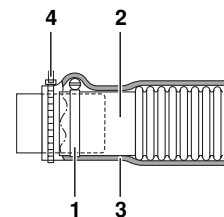

- Do not use a trap in the drain piping.
- Never put the end of the drain hose into water.

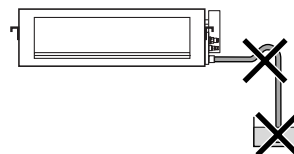

2. Insulate the drain hose inside the building.

3. Drain check

- Execute the drain check before installing the duct
- Make sure that the drain hose is firmly connected
- Pour some water into the drain pan to check if the water flows smoothly.

ELECTRIC WIRING WORK

General instructions

- All field supplied parts and materials and electric works must conform to local codes.
- Use copper wire only.
- Follow the "Wiring diagram" attached to the switch box cover to wire the outdoor unit, indoor units and the remote controller. For details on hooking up the remote controller, refer to the "Installation manual of the remote controller".
- All wiring must be performed by an authorized electrician.
- A circuit breaker capable of shutting down power supply to the entire system must be installed.

Specifications for field wire

| Connection | Wire | Size |
|------------------------|-------------------|---------------------------|
| Between indoor units | H05VV-U4G | Local codes |
| Unit-Remote controller | Sheathed wire (2) | 0.75-1.25 mm ² |

NOTE For details, refer to the chapter "Wiring example" on page 4.

Use H07RN-F as wiring between indoor units in case of no protection.

Allowable length of transmission wiring between the indoor unit and the remote controller is max. 500 m.

WIRING EXAMPLE AND HOW TO SET THE REMOTE CONTROLLER

How to connect wiring

Remove the switch box cover as shown in figure 15, and make the connections.

- 1 Switch box
- 2 Switch box cover
- 3 Power supply wiring port
- 4 Transmission wiring port
- 5 Wiring diagram
- 6 Wiring clamp
- 7 Remote controller wiring
- 8 Terminal for remote controller wiring
- 9 Power supply wiring
- 10 Terminal for power supply wiring
- 11 Earth screw

Precautions

1. Observe the notes mentioned below when wiring to the power supply terminal board.
 - Do not connect wires of different gauge to the same power supply terminal. (Looseness in the connection may cause overheating.)
 - When connecting wires of the same gauge, connect them according to the figure.

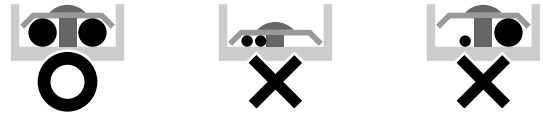

2. Do not connect wires of different gauge to the same grounding terminal. Looseness in the connection may deteriorate the protection.
3. Remote controller cords and wires connecting the units should be located at least 50 mm away from power supply wiring. Not following this guideline may result in malfunction due to electrical noise.
4. For the remote controller wiring, refer to the "Installation manual of the remote controller" supplied with the remote controller.

NOTE The customer has the ability to select the remote controller thermistor.

5. Never connect the power supply wiring to the terminal board for transmission wiring. This mistake could damage the entire system.
6. Use only specified wires and tightly connect wires to the terminals. Be careful that wires do not place external stress on the terminals. Keep wiring in neat order so that they do not obstruct other equipment such as popping open the switch box cover. Make sure the cover closes tight. Incomplete connections could result in overheating, and in the worst case, electric shock or fire.

WIRING EXAMPLE

- Fit the power supply wiring of each system with a switch and fuse as shown in figure 7, 9 and 10.

- 1 Power supply
- 2 Main switch
- 3 Fuse
- 4 Outdoor unit
- 5 Indoor unit (M=master, S=slave)
- 6 Remote controller (optional accessory)

Complete system example (3 systems)

When using 1 remote controller for 1 indoor unit. (Normal operation) (See figure 10)

For group control (See figure 7)

For group control, cut the jumper indicated as "master/slave" on the PCB of the "slave" indoor units (=slave PCB). Do not cut the jumper on the PCB of the indoor unit to which the remote controller is connected (=master PCB).



Use with 2 remote controllers (See figure 9)

NOTE It is not necessary to designate an indoor unit address when using group control. The address is automatically set when the power is activated.

Precautions

1. A single switch can be used to supply power to units on the same system. However, branch switches and branch circuit breakers must be selected carefully.
2. Do not ground the equipment on gas pipes, water pipes, lightning rods or crossground with telephones. Improper grounding could result in electric shock.

FIELD SETTING

Field setting must be made from the remote controller in accordance with the installation condition. [Refer to the manual of the remote controller.](#)

Setting of static pressure

- Change the SECOND CODE No. according to [Table 2](#) depending on the resistance of the connection duct.

Table 2

| External static pressure | Mode No. | FIRST CODE No. | SECOND CODE No. |
|--------------------------|----------|----------------|-----------------|
| Low: 50 Pa | 13 (23) | 6 | 01 |
| High: 100 Pa | | | 02 |

The unit is factory set for high static pressure (SECOND CODE No. 02) at the time of shipping.

Setting air filter sign

- Remote controllers are equipped with liquid crystal display air filter signs to display the time to clean air filters.
- Change the SECOND CODE No. According to [Table 3](#) depending on the amount of dirt or dust in the room. (SECOND CODE No. Is factory set to "01" for filter contamination-light.)

Table 3

| Setting | Spacing time of display air filter sign (long life type) | Mode No. | FIRST CODE No. | SECOND CODE No. |
|----------------------------------|--|----------|----------------|-----------------|
| Air filter contamination - light | ±2500 hrs | 10 (20) | 0 | 01 |
| Air filter contamination - heavy | ±1250 hrs | | | 02 |

Control by 2 Remote Controllers (Controlling 1 indoor unit by 2 remote controllers)

[Refer to the manual of the remote controller.](#)

Computerised control (forced off and on/off operation)

- 1 Wire specifications and how to perform wiring
 - Connect the input wire (option) to connector X40A on the indoor PCB.

Wire specifications (to extend the optional wire):

| Wire specification | Sheathed vinyl cord or cable (2 wire) |
|--------------------|---|
| Gauge | 0.75-1.25 mm ² |
| Length | Max. 100 m |
| External terminal | Contact that can ensure the minimum applicable load of 15 V DC, 10 mA |

(See figure 8)

- 1 Input A (Input "ON"=closed contact)
- 2 Actuation
 - The following table explains "forced off" and "on/off operations" in response to input A.

| Forced off | on/off operation |
|---|---|
| Input "on" stops operation + disables control | input off → on: starts operation remote, control is still enabled |
| Input "off" enables control | input on → off: stops operation remote, control is still enabled |

- 3 How to select forced off and on/off operation

Change the second code No. according to [Table 4](#). (Second code No. is factory set to "01" for forced off.)

Table 4

| Setting | Mode No. | FIRST CODE No. | SECOND CODE No. |
|------------------|----------|----------------|-----------------|
| Forced off | 12 (22) | 1 | 01 |
| ON/OFF operation | | | 02 |

TEST OPERATION

Refer to the section of "[For the following items, take special care during construction and check after installation is finished](#)" on page 2.

- After finishing the construction of refrigerant piping, drain piping, and electric wiring, conduct test operation accordingly to protect the unit.
- 1 Open the gas side stop valve.
 - 2 Open the liquid side stop valve.
 - 3 Electrify crank case heater for 6 hours. (Not necessary for the straight cooling type.)
 - 4 Set to cooling operation with the remote controller and start operation by pushing ON/OFF button.
 - 5 Press Inspection/Test Operation button 4 times and operate at Test Operation mode for 3 minutes.
 - 6 Press Inspection/Test Operation button and operate normally.
 - 7 Confirm function of unit during operation. [Refer to the manual of the remote controller on how to operate.](#)



NOTE If the main power supply is turned off during operation, operation will restart automatically after the power turns back on again.

Precautions

In case something is wrong with the unit and it does not operate, refer to the malfunction diagnosis label attached to the unit.

OPERATING THE UNIT

NAMES AND FUNCTIONS OF PARTS (See figure 14)

- 1 Indoor unit
- 2 Outdoor unit
- 3 Remote controller
- 4 Inlet air
- 5 Discharged air
- 6 Refrigerant piping
- 7 Drain pipe
- 8 Ground wire
Wire to ground outdoor unit to prevent electrical shocks.
- 9 Air filter
- 10 Connection electric wire



- Never let the indoor unit and the remote controller get wet.
It may cause an electric shock or a fire.
- Never use flammable spray such as hair spray, lacquer or paint near the unit.
It may cause a fire.
- Never replace a fuse with that of a wrong ampere rating or other wires when the fuse blows out.
Use of wire or copper wire may cause the unit to break down or cause a fire.
- Never insert objects such as sticks into the air inlet or outlet. It is dangerous for an object to touch the fan when it is turning at high speed.
- Never remove the fan grill of the outdoor unit.
The rotating fan at high speed without the guard is very dangerous.
- Never inspect or service the unit by yourself.
Ask a qualified service person to perform this work.

OPERATION RANGE (See figure 11)

If operating outside the following conditions, safety devices may activate, rendering the air conditioner inoperable or may cause the indoor unit to sweat.

The setting temperature range of the remote controller is 16°C - 32°C.

(DB = dry bulb, WB = wet bulb, ❄ = cooling, ☀ = heating, 🏠 = indoor, 🏠 = outdoor, ℹ °C = temperature, 💧 = humidity)

OPERATION PROCEDURE



- If a function that is not available is selected, the message NOT AVAILABLE will appear.
- Operating procedure varies with heat pump type and straight cooling type. Contact your Daikin dealer to confirm your system type.
- To protect the unit, turn on the main power switch 6 hours before operation.
- If the main power supply is turned off during operation, operation will restart automatically after the power turns back on again.

Precautions for group control system or two remote controller control system

This system provides two other control systems beside individual control (one remote controller controls one indoor unit) system. Confirm the following if your unit is of the following control system type.

- Group control system
One remote controller controls up to 16 indoor units.
All indoor units are equally set.
- Two remote controller control system
Two remote controllers control one indoor unit (In case of group control system, one group of indoor units). The unit is individually operated.

NOTE



Contact your Daikin dealer in case of changing the combination or setting of group control and two remote controller control systems.

OPTIMUM OPERATION

Observe the following precautions to ensure the system operates properly.

- Adjust the air outlet properly and avoid direct air flow to room inhabitants.
- Adjust the room temperature properly for a comfortable environment. Avoid excessive heating or cooling.
- Prevent direct sunlight from entering a room during cooling operation by using curtains or blinds.
- Keep doors and windows closed. If the doors and windows remain open, room air will flow out and decrease the effect of cooling and heating.
- Never place objects near the air inlet and the air outlet of the unit. It may retard effectiveness or cause operation to stop.
- Turn off the main power supply switch when not using for long periods of time. Electricity is consumed as long as the switch is on. Turn off the main power supply switch in order to save energy. Turn on the main power supply switch 6 hours before restarting operation in order to ensure smooth operation. (Refer to "Maintenance" on page 8.)
- When the display shows "🏠" (TIME TO CLEAN AIR FILTER), have a qualified service person to clean the filters. (Refer to "Maintenance" on page 8.)

NOT A MALFUNCTION OF THE AIR CONDITIONER

The following symptoms do not indicate air conditioner malfunction.

The system does not operate

- The system does not restart immediately after the ON/OFF button is pressed.
If the OPERATION lamp lights, the system is in its normal operating condition.
It does not restart immediately because one of its safety devices actuates to prevent the system from being overloaded.
The system will turn on again automatically after three minutes.
- The system does not restart immediately when the TEMPERATURE SETTING button is returned to its former position after pushing.
It does not restart immediately because one of its safety devices actuates to prevent the system from being overloaded.
The system will turn on again automatically after three minutes.
- The system does not start when the display shows ""
(EXTERNAL CONTROL ICON) and it flashes for a few seconds after pressing an operation button.
This is because the system is controlled or disabled by another controller with a higher priority.
When the display flashes, it indicates that the system cannot be controlled by this indoor unit.
- The system does not start immediately after the power supply is turned on.
Wait one minute until the micro computer is prepared for operation.

White mist comes out of a unit

- When humidity is high during cooling operation (In oily or dusty places).
If the inside of an indoor unit is extremely contaminated, the temperature distribution inside a room becomes uneven. It is necessary to clean the inside of the indoor unit. Ask your Daikin dealer for details on cleaning the unit. This operation requires a qualified service person.
- When the system is changed over to HEATING OPERATION after DEFROST OPERATION.
Moisture generated by DEFROST becomes steam and exits.

Noise of air conditioners

- A continuous low "hissing" sound is heard when the system is in COOLING or DEFROST OPERATION.
This is the sound of refrigerant gas flowing through both indoor and outdoor units.
- A "hissing" sound which is heard at the start or immediately after the stop of operation or which is heard at the start or immediately after the stop of DEFROST OPERATION.
This is the noise of refrigerant caused by flow stop and flow change.
- A "squeaking" sound is heard when the system is in operation or after the stop of operation.
Expansion and contraction of plastic parts caused by temperature change makes this noise.

Dust from the units

- Dust may blow out from the unit after starting operation from long resting time. Dust absorbed by the unit blows out.

The units give off odours

- The unit absorbs the smell of rooms, furniture, cigarettes, etc., and then emits them.

The liquid crystal display of the remote controller shows "BB"

- Happens immediately after the main power supply switch is turned on.
Shows that the remote controller is in normal condition.
Continues temporarily.

TROUBLESHOOTING

If one of the following malfunctions occurs, take the measures shown below and contact your Daikin dealer.

The system must be repaired by a qualified service person.

- If a safety device such as a fuse, a breaker, or an earth leakage breaker frequently actuates, or ON/OFF switch does not properly work.
Measure: Turn off the main power switch.
- If water leaks from unit.
Measure: Stop the operation.
- If the display "" (INSPECTION), "UNIT No.", and the OPERATION lamp flashes and the "MALFUNCTION CODE" appears.
Measure: Notify your Daikin dealer and inform him/her of the display.

If the system does not operate properly, except for the above mentioned case, and none of the above mentioned malfunctions is evident, investigate the system according to the following procedures.

If the system does not operate at all.

- Check if there is a power failure.
Wait until power is restored. If power failure occurs during operation, the system automatically restarts immediately after the power supply recovers.
- Check if the fuse has blown or breaker has been tripped.
Change the fuse or set the breaker.

If the system stops operating after operation is complete.

- Check if the air inlet or outlet of outdoor or indoor unit is blocked by obstacles.
Remove the obstacle and make it well-ventilated.
- Check if the air filter is clogged.
Ask a qualified service person to clean the air filter.

The system operates but it does not sufficiently cool or heat.

- If the air inlet or outlet of the indoor or the outdoor unit is blocked with obstacles.
Remove the obstacle and make it well-ventilated.
- If the air filter is clogged.
Ask a qualified service person to clean the air filter.
- If the set temperature is not proper. (Refer to the manual of the remote controller.)
- If the FAN SPEED CONTROL button is set to LOW SPEED. (Refer to the manual of the remote controller.)
- If the doors or the windows are open. Shut doors or windows to prevent wind from coming in.
- If direct sunlight enters the room (when cooling).
Use curtains or blinds.
- When there are too many inhabitants in the room. Cooling effect decreases if heat gain of the room is too large.
- If the heat source of the room is excessive (when cooling).
Cooling effect decreases if heat gain of the room is too large.

MAINTENANCE



- Only a qualified service person is allowed to perform maintenance.
- Before obtaining access to terminal devices, all power supply circuits must be interrupted.
- Do not use water or air of 50°C or higher for cleaning air filters and outside panels.
- When cleaning the heat exchanger, be sure to remove the switchbox and fan motor. Water or detergent may deteriorate the insulation of electronic components and result in burn-out of these components.

How to clean the air filter

Clean the air filter when the display shows "" (TIME TO CLEAN AIR FILTER).

Increase the frequency of cleaning if the unit is installed in a room where the air is extremely contaminated.

(As a yardstick for yourself, consider cleaning the filter once a half year.)

If the dirt becomes impossible to clean, change the air filter. (Air filter for exchange is optional.)

(See figure 12)

- 1 Remove the filter holding plate (1) from the bottom plate.
- 2 Remove the air filter (2) by sliding it downwards.
- 3 Clean the air filter. (Refer to figure 13  air flow direction over filter.)
Use vacuum cleaner or wash the air filter with water.
When the air filter is very dirty, use soft brush and neutral detergent.
Remove water and dry in the shade.
- 4 Replace the air filter by sliding it between the guiding plates.
- 5 Replace the filter holding plate to the bottom plate.
- 6 After turning on the power, press FILTER SIGN RESET button.
The "TIME TO CLEAN AIR FILTER" display is turned off.

How to clean air outlet

- Clean with soft cloth.
- When it is difficult to remove stains, use water or neutral detergent.

NOTE



Do not use gasoline, benzene, thinner, polishing powder, liquid insecticide. It may cause discoloring or warping.

Do not let the indoor unit get wet. It may cause an electric shock or a fire.

Start-up after a long stop

- Confirm the following.
 - Check that the air inlet and outlet are not blocked. Remove any obstacle.
 - Check if the earth is connected.
- Clean the air filter.
 - After cleaning the air filter, make sure to attach it.
- Turn on the main power supply switch.
 - The control panel display lights when the power is turned on.
 - To protect the unit, turn on the main power switch at least 6 hours before operation.

What to do when stopping the system for a long period

- Turn on FAN OPERATION for a half day and dry the unit.
 - [Refer to the manual of the remote controller.](#)
- Cut off the power supply.
 - When the main power switch is turned on, some wattage is being consumed even if the system is not operating.
 - The remote controller display is turned off when the main power switch is turned off.

Disposal requirements

Dismantling of the unit, treatment of the refrigerant, oil and eventual other parts, should be done in accordance with the relevant local and national regulations.

