

Service Manual

Inverter Pair Wall Mounted Type FTX/ATX-K Series

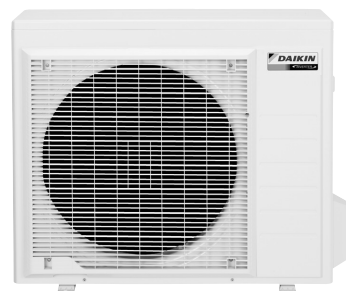
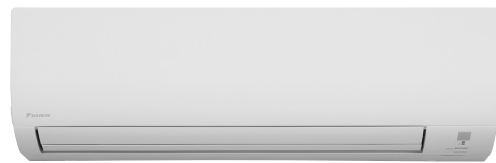

[Applicable Models]
● Inverter Pair: Heat Pump

Inverter Pair Wall Mounted Type FTX/ATX-K Series

●Heat Pump

Indoor Unit

FTX20K(2)V1B	FTX50K(M/2)V1B	ATX20K(2)V1B
FTX25K(2)V1B	FTX60K(M/2)V1B	ATX25K(2)V1B
FTX35K(2)V1B	FTX71K(M/2)V1B	ATX35K(2)V1B

Outdoor Unit

RX20K2/5V1B	RX50K(2)V1B	ARX20K2V1B
RX25K2/5V1B	RX60K(2)V1B	ARX25K2V1B
RX35K2/5V1B	RX71K(2)V1B	ARX35K2V1B

Version log

Month / Year	Version	Revised contents
01 / 2016	SiBE041525E	(A)RX20-35K2
02 / 2016	SiBE041525F	Include RX71K & FTX71KM + standard S21 connection

1. Safety Cautions.....	vi
1.1 Warnings and Cautions Regarding Safety of Workers.....	vi
1.2 Warnings and Cautions Regarding Safety of Users.....	viii
2. Icons Used.....	X
Part 1 - List of Functions.....	1
1. Functions.....	2
Part 2 - Specifications.....	4
1. Specifications.....	5
Part 3 - Printed Circuit Board Connector Wiring Diagram.....	6
1. Indoor Unit.....	7
1.1 20/25/35 Class.....	7
1.2 50/60/71 Class.....	9
2. Outdoor Unit.....	12
2.1 20/25/35 Class.....	12
2.2 50/60/71 class.....	13
Part 4 - Functions and Control.....	14
1. Main Functions.....	15
1.1 Temperature Control.....	15
1.2 Frequency Principle.....	15
1.3 Airflow Direction Control.....	17
1.4 Fan Speed Control for Indoor Unit.....	18
1.5 Program Dry Operation.....	19
1.6 Automatic Operation.....	20
1.7 Thermostat Control.....	21
1.8 NIGHT SET Mode.....	22
1.9 ECONO Operation.....	22
1.10 Inverter POWERFUL Operation.....	23
1.11 Other Functions.....	24
2. Thermistor Functions.....	25
3. Control Specification.....	26
3.1 Mode Hierarchy.....	26
3.2 Frequency Control.....	27
3.3 Controls at Mode Changing / Start-up.....	29
3.4 Discharge Pipe Temperature Control.....	31
3.5 Input Current Control.....	32
3.6 Freeze-up Protection Control.....	33
3.7 Heating Peak-cut Control.....	33
3.8 Outdoor Fan Control.....	34
3.9 Liquid Compression Protection Function.....	34
3.10 Defrost Control.....	35
3.11 Electronic Expansion Valve Control.....	36
3.12 Malfunctions.....	39





Part 5 - Remote Controller	40
1. Remote Controller	41
Part 6 - Service Diagnosis	43
1. General Problem Symptoms and Check Items	44
2. Troubleshooting with LED	45
2.1 Indoor Unit.....	45
2.2 Outdoor Unit.....	45
3. Service Diagnosis	46
4. Troubleshooting	49
4.1 Error Codes and Descriptions	49
4.2 Indoor Unit PCB Abnormality	50
4.3 Freeze-up Protection Control / Heating Peak-cut Control	51
4.4 Fan Motor (DC Motor) or Related Abnormality.....	52
4.5 Thermistor or Related Abnormality (Indoor Unit).....	54
4.6 Low-voltage Detection or Over-voltage Detection.....	55
4.7 Signal Transmission Error (Between Indoor Unit and Outdoor Unit).....	57
4.8 Unspecified Voltage (Between Indoor Unit and Outdoor Unit)	59
4.9 Outdoor Unit PCB Abnormality.....	60
4.10 OL Activation (Compressor Overload)	61
4.11 Compressor Lock	63
4.12 DC Fan Lock	64
4.13 Input Overcurrent Detection	65
4.14 Four Way Valve Abnormality.....	66
4.15 Discharge Pipe Temperature Control.....	68
4.16 High Pressure Control in Cooling	69
4.17 Compressor System Sensor Abnormality	70
4.18 Position Sensor Abnormality	71
4.19 Thermistor or Related Abnormality (Outdoor Unit).....	73
4.20 Electrical Box Temperature Rise.....	75
4.21 Radiation Fin Temperature Rise	76
4.22 Output Overcurrent Detection	77
5. Check.....	79
5.1 Thermistor Resistance Check	79
5.2 Indoor Fan Motor Connector Output Check	80
5.3 Power Supply Waveforms Check.....	81
5.4 Electronic Expansion Valve Check.....	81
5.5 Four Way Valve Performance Check	82
5.6 Inverter Unit Refrigerant System Check.....	82
5.7 Inverter Analyzer Check	83
5.8 Rotation Pulse Check on the Outdoor Unit PCB	85
5.9 Installation Condition Check.....	86
5.10 Discharge Pressure Check.....	86
5.11 Outdoor Fan System Check	87
5.12 Main Circuit Short Check.....	87
5.13 Power Module Check	88

Part 7 - Trial Operation and Field Settings	90
1. Tips for Servicing	91
1.1 Pump Down Operation	91
1.2 Forced Cooling Operation	91
2. Trial Operation	92
3. Field Settings	93
3.1 Temperature Display Switch	93
3.2 When 2 Units are installed in 1 Room	93
4. Silicone Grease on Power Transistor / Diode Bridge	94
Part 8 - Appendix	95
1. Piping Diagrams	96
1.1 Indoor Unit	96
1.2 Outdoor Unit	97
2. Wiring Diagrams	99
2.1 Indoor Unit	99
2.2 Outdoor Unit	101



1. Safety Cautions

Be sure to read the following safety cautions before conducting repair work. After the repair work is complete, be sure to conduct a test operation to ensure that the equipment operates normally, and explain the cautions for operating the product to the customer.







Caution Items





The caution items are classified into  **Warning** and  **Caution**. The  **Warning** items are especially important since death or serious injury can result if they are not followed closely. The  **Caution** items can also lead to serious accidents under some conditions if they are not followed. Therefore, be sure to observe all the safety caution items described below.







Pictograms



-  This symbol indicates an item for which caution must be exercised. The pictogram shows the item to which attention must be paid.
-  This symbol indicates a prohibited action. The prohibited item or action is shown in the illustration or near the symbol.
-  This symbol indicates an action that must be taken, or an instruction. The instruction is shown in the illustration or near the symbol.

1.1 Warnings and Cautions Regarding Safety of Workers









 Warning	
Do not store equipment in a room with fire sources (e.g., naked flames, gas appliances, electric heaters).	
Be sure to disconnect the power cable from the socket before disassembling equipment for repair. Working on equipment that is connected to the power supply may cause an electrical shock. If it is necessary to supply power to the equipment to conduct the repair or inspect the circuits, do not touch any electrically charged sections of the equipment.	
If refrigerant gas is discharged during repair work, do not touch the discharged refrigerant gas. Refrigerant gas may cause frostbite.	
When disconnecting the suction or discharge pipe of the compressor at the welded section, evacuate the refrigerant gas completely at a well-ventilated place first. If there is gas remaining inside the compressor, the refrigerant gas or refrigerating machine oil discharges when the pipe is disconnected, and it may cause injury.	
If refrigerant gas leaks during repair work, ventilate the area. Refrigerant gas may generate toxic gases when it contacts flames.	
Be sure to discharge the capacitor completely before conducting repair work. The step-up capacitor supplies high-voltage electricity to the electrical components of the outdoor unit. A charged capacitor may cause an electrical shock.	







 Warning	
<p>Do not turn the air conditioner on or off by plugging in or unplugging the power cable. Plugging in or unplugging the power cable to operate the equipment may cause an electrical shock or fire.</p>	
<p>Be sure to wear a safety helmet, gloves, and a safety belt when working in a high place (more than 2 m). Insufficient safety measures may cause a fall.</p>	
<p>In case of R-32 / R-410A refrigerant models, be sure to use pipes, flare nuts and tools intended for the exclusive use with the R-32 / R-410A refrigerant. The use of materials for R-22 refrigerant models may cause a serious accident, such as a damage of refrigerant cycle or equipment failure.</p>	
<p>Do not mix air or gas other than the specified refrigerant (R-32 / R-410A / R-22) in the refrigerant system. If air enters the refrigerant system, an excessively high pressure results, causing equipment damage and injury.</p>	





 Caution	
<p>Do not repair electrical components with wet hands. Working on the equipment with wet hands may cause an electrical shock.</p>	
<p>Do not clean the air conditioner with water. Washing the unit with water may cause an electrical shock.</p>	
<p>Be sure to provide an earth / grounding when repairing the equipment in a humid or wet place, to avoid electrical shocks.</p>	
<p>Be sure to turn off the power switch and unplug the power cable when cleaning the equipment. The internal fan rotates at a high speed, and may cause injury.</p>	
<p>Be sure to conduct repair work with appropriate tools. The use of inappropriate tools may cause injury.</p>	
<p>Be sure to check that the refrigerating cycle section has cooled down enough before conducting repair work. Working on the unit when the refrigerating cycle section is hot may cause burns.</p>	





 Caution	
<p>Conduct welding work in a well-ventilated place. Using a welder in an enclosed room may cause oxygen deficiency.</p>	

1.2 Warnings and Cautions Regarding Safety of Users

 Warning	
<p>Do not store the equipment in a room with fire sources (e.g., naked flames, gas appliances, electric heaters).</p>	
<p>Be sure to use parts listed in the service parts list of the applicable model and appropriate tools to conduct repair work. Never attempt to modify the equipment. The use of inappropriate parts or tools may cause an electrical shock, excessive heat generation or fire.</p>	
<p>If the power cable and lead wires are scratched or have deteriorated, be sure to replace them. Damaged cable and wires may cause an electrical shock, excessive heat generation or fire.</p>	
<p>Do not use a joined power cable or extension cable, or share the same power outlet with other electrical appliances, since it may cause an electrical shock, excessive heat generation or fire.</p>	
<p>Be sure to use an exclusive power circuit for the equipment, and follow the local technical standards related to the electrical equipment, the internal wiring regulations, and the instruction manual for installation when conducting electrical work. Insufficient power circuit capacity and improper electrical work may cause an electrical shock or fire.</p>	
<p>Be sure to use the specified cable for wiring between the indoor and outdoor units. Make the connections securely and route the cable properly so that there is no force pulling the cable at the connection terminals. Improper connections may cause excessive heat generation or fire.</p>	
<p>When wiring between the indoor and outdoor units, make sure that the terminal cover does not lift off or dismount because of the cable. If the cover is not mounted properly, the terminal connection section may cause an electrical shock, excessive heat generation or fire.</p>	
<p>Do not damage or modify the power cable. Damaged or modified power cables may cause an electrical shock or fire. Placing heavy items on the power cable, or heating or pulling the power cable may damage it.</p>	





 Warning	
<p>Do not mix air or gas other than the specified refrigerant (R-32 / R-410A / R-22) in the refrigerant system. If air enters the refrigerant system, an excessively high pressure results, causing equipment damage and injury.</p>	
<p>If the refrigerant gas leaks, be sure to locate the leaking point and repair it before charging the refrigerant. After charging the refrigerant, make sure that there is no leak. If the leaking point cannot be located and the repair work must be stopped, be sure to pump-down, and close the service valve, to prevent refrigerant gas from leaking into the room. Refrigerant gas itself is harmless, but it may generate toxic gases when it contacts flames, such as those from fan type and other heaters, stoves and ranges.</p>	
<p>When relocating the equipment, make sure that the new installation site has sufficient strength to withstand the weight of the equipment. If the installation site does not have sufficient strength or the installation work is not conducted securely, the equipment may fall and cause injury.</p>	
<p>Check to make sure that the power cable plug is not dirty or loose, then insert the plug into a power outlet securely. If the plug is dusty or has a loose connection, it may cause an electrical shock or fire.</p>	
<p>When replacing the coin battery in the remote controller, be sure to dispose of the old battery to prevent children from swallowing it. If a child swallows the coin battery, see a doctor immediately.</p>	

 Caution	
<p>Installation of a leakage breaker is necessary in some cases depending on the conditions of the installation site, to prevent electrical shocks.</p>	
<p>Do not install the equipment in a place where there is a possibility of combustible gas leaks. If combustible gas leaks and remains around the unit, it may cause a fire.</p>	
<p>Check to see if parts and wires are mounted and connected properly, and if connections at the soldered or crimped terminals are secure. Improper installation and connections may cause excessive heat generation, fire or an electrical shock.</p>	
<p>If the installation platform or frame has corroded, replace it. A corroded installation platform or frame may cause the unit to fall, resulting in injury.</p>	

 Caution	
<p>Check the earth / grounding, and repair it if the equipment is not properly earthed / grounded. Improper earth / grounding may cause an electrical shock.</p>	
<p>Be sure to measure insulation resistance after the repair, and make sure that the resistance is 1 MΩ or higher. Faulty insulation may cause an electrical shock.</p>	
<p>Be sure to check the drainage of the indoor unit after the repair. Faulty drainage may cause water to enter the room and wet the furniture and floor.</p>	
<p>Do not tilt the unit when removing it. The water inside the unit may spill and wet the furniture and floor.</p>	

2. Icons Used

The following icons are used to attract the attention of the reader to specific information.

Icon	Type of Information	Description
 Warning	Warning	A Warning is used when there is danger of personal injury.
 Caution	Caution	A Caution is used when there is danger that the reader, through incorrect manipulation, may damage equipment, lose data, get an unexpected result or have to restart (part of) a procedure.
 Note:	Note	A Note provides information that is not indispensable, but may nevertheless be valuable to the reader, such as tips and tricks.
	Reference	A Reference guides the reader to other places in this binder or in this manual, where he/she will find additional information on a specific topic.

Part 1

List of Functions

1. Functions.....2

1. Functions

Category	Functions	FTX20/25/35K(2)V1B RX20/25/35K2/5V1B	FTX50/60/71K(M/2)V1B RX50/60/71K(2)V1B	Category	Functions	FTX20/25/35K(2)V1B RX20/25/35K2/5V1B	FTX50/60/71K(M/2)V1B RX50/60/71K(2)V1B
Basic Functions	Inverter (with inverter power control)	●	●	Health & Cleanliness	Air-purifying filter	—	—
	Operation limit for cooling (°CDB)	-10 ~ 46	-10 ~ 46		Photocatalytic deodorizing filter	—	—
	Operation limit for heating (°CWB)	-15 ~ 18	-15 ~ 18		Air-purifying filter with photocatalytic deodorizing function	—	—
	PAM control	●	●		Titanium apatite photocatalytic air-purifying filter	●	●
	Standby electricity saving	●	●		Air filter (prefilter)	●	●
Compressor	Oval scroll compressor	—	—	Wipe-clean flat panel	●	●	
	Swing compressor	●	●	Washable grille	—	—	
	Rotary compressor	—	—	MOLD PROOF operation	—	—	
	Reluctance DC motor	●	●	Good-sleep cooling operation	—	—	
Comfortable Airflow	Power-airflow flap	●	—	Timer	WEEKLY TIMER operation	—	—
	Power-airflow dual flaps	—	●		24-hour ON/OFF TIMER	—	—
	Power-airflow diffuser	—	—		Count up-down ON/OFF timer	●	●
	Wide-angle louvers	●	●		NIGHT SET mode	●	●
	Auto-swing (up and down)	●	●	Worry Free (Reliability & Durability)	Auto-restart (after power failure)	●	●
	Auto-swing (right and left)	—	—		Self-diagnosis (R/C, LED)	●	●
	3-D airflow	—	—		Wiring error check function	—	—
COMFORT AIRFLOW operation	●	●	Anti-corrosion treatment of outdoor heat exchanger	●	●		
Comfort Control	Auto fan speed	●	●	Flexibility	Multi-split / split type compatible indoor unit	●	●
	Indoor unit quiet operation	●	●		H/P, C/O compatible indoor unit	—	—
	NIGHT QUIET mode (automatic)	—	—		Flexible power supply correspondence	—	—
	OUTDOOR UNIT QUIET operation (manual)	—	—		Chargeless	10 m	10 m
	2-area INTELLIGENT EYE operation	—	—		Either side drain (right or left)	●	●
	INTELLIGENT EYE operation	—	—		Power selection	—	—
	Quick warming function (preheating control)	●	●		°C/°F changeover R/C temperature display (factory setting: °C)	●	●
	Hot-start function	●	●		Remote Control	5-room centralized controller (option)	●
Automatic defrosting	●	●	Remote control adaptor (normal open pulse contact) (option)	●		●	
Operation	Automatic operation	●	●	Remote control adaptor (normal open contact) (option)		●	●
	Program dry operation	●	●	DIII-NET compatible (adaptor) (option)	●	●	
	Fan only	●	●	Remote Controller	Wireless	●	●
Lifestyle Convenience	New POWERFUL operation (non-inverter)	—	—		Wired (option)	●	●
	Inverter POWERFUL operation	●	●				
	Priority-room setting	—	—				
	COOL/HEAT mode lock	—	—				
	HOME LEAVE operation	—	—				
	ECONO operation	●	●				
	Indoor unit ON/OFF button	●	●				
	Signal receiving sign	●	●				
R/C with back light	—	—					
Temperature display	—	—					

Note: ● : Available
— : Not available

Category	Functions	ATX20/25/35K(2)V1B AFX20/25/35K2V1B	Category	Functions	ATX20/25/35K(2)V1B AFX20/25/35K2V1B
Basic Functions	Inverter (with inverter power control)	●	Health & Cleanliness	Air-purifying filter	—
	Operation limit for cooling (°CDB)	-10 ~ 46		Photocatalytic deodorizing filter	—
	Operation limit for heating (°CWB)	-15 ~ 18		Air-purifying filter with photocatalytic deodorizing function	—
	PAM control	●		Titanium apatite photocatalytic air-purifying filter	●
	Standby electricity saving	●		Air filter (prefilter)	●
Compressor	Oval scroll compressor	—		Wipe-clean flat panel	●
	Swing compressor	●		Washable grille	—
	Rotary compressor	—		MOLD PROOF operation	—
	Reluctance DC motor	●		Good-sleep cooling operation	—
Comfortable Airflow	Power-airflow flap	●		Timer	WEEKLY TIMER operation
	Power-airflow dual flaps	—	24-hour ON/OFF TIMER		—
	Power-airflow diffuser	—	Count up-down ON/OFF timer		●
	Wide-angle louvers	●	NIGHT SET mode		●
	Auto-swing (up and down)	●	Worry Free (Reliability & Durability)	Auto-restart (after power failure)	●
	Auto-swing (right and left)	—		Self-diagnosis (R/C, LED)	●
	3-D airflow	—		Wiring error check function	—
COMFORT AIRFLOW operation	●	Anti-corrosion treatment of outdoor heat exchanger	●		
Comfort Control	Auto fan speed	●	Flexibility	Multi-split / split type compatible indoor unit	●
	Indoor unit quiet operation	●		H/P, C/O compatible indoor unit	—
	NIGHT QUIET mode (automatic)	—		Flexible power supply correspondence	—
	OUTDOOR UNIT QUIET operation (manual)	—		Chargeless	10 m
	2-area INTELLIGENT EYE operation	—		Either side drain (right or left)	●
	INTELLIGENT EYE operation	—		Power selection	—
	Quick warming function (preheating control)	●		°C/°F changeover R/C temperature display (factory setting: °C)	●
	Hot-start function	●		Remote Control	5-room centralized controller (option)
Automatic defrosting	●	Remote control adaptor (normal open pulse contact) (option)	●		
Operation	Automatic operation	●	Remote control adaptor (normal open contact) (option)		●
	Program dry operation	●	DIII-NET compatible (adaptor) (option)		●
	Fan only	●	Remote Controller	Wireless	●
Lifestyle Convenience	New POWERFUL operation (non-inverter)	—		Wired (option)	●
	Inverter POWERFUL operation	●			
	Priority-room setting	—			
	COOL/HEAT mode lock	—			
	HOME LEAVE operation	—			
	ECONO operation	●			
	Indoor unit ON/OFF button	●			
	Signal receiving sign	●			
R/C with back light	—				
Temperature display	—				

Note: ● : Available
— : Not available

Part 2 Specifications

1. Specifications5

1. Specifications

See corresponding databook

Part 3

Printed Circuit Board

Connector Wiring Diagram

1. Indoor Unit.....	7
1.1 20/25/35 Class	7
1.2 50/60/71 Class	9
2. Outdoor Unit.....	12
2.1 20/25/35 Class	12
2.2 50/60/71 class	13

1. Indoor Unit

1.1 20/25/35 Class

Control PCB (PCB1)

- 1) S6 Connector for swing motor (horizontal blade)
- 2) S26 Connector for display PCB
- 3) S32 Connector for indoor heat exchanger thermistor
- 4) S200 Connector for DC fan motor
- 5) H1, H2, H3, FG Connector for terminal board
- 6) FU1 Fuse (3.15 A, 250 V)
- 7) V2 Varistor

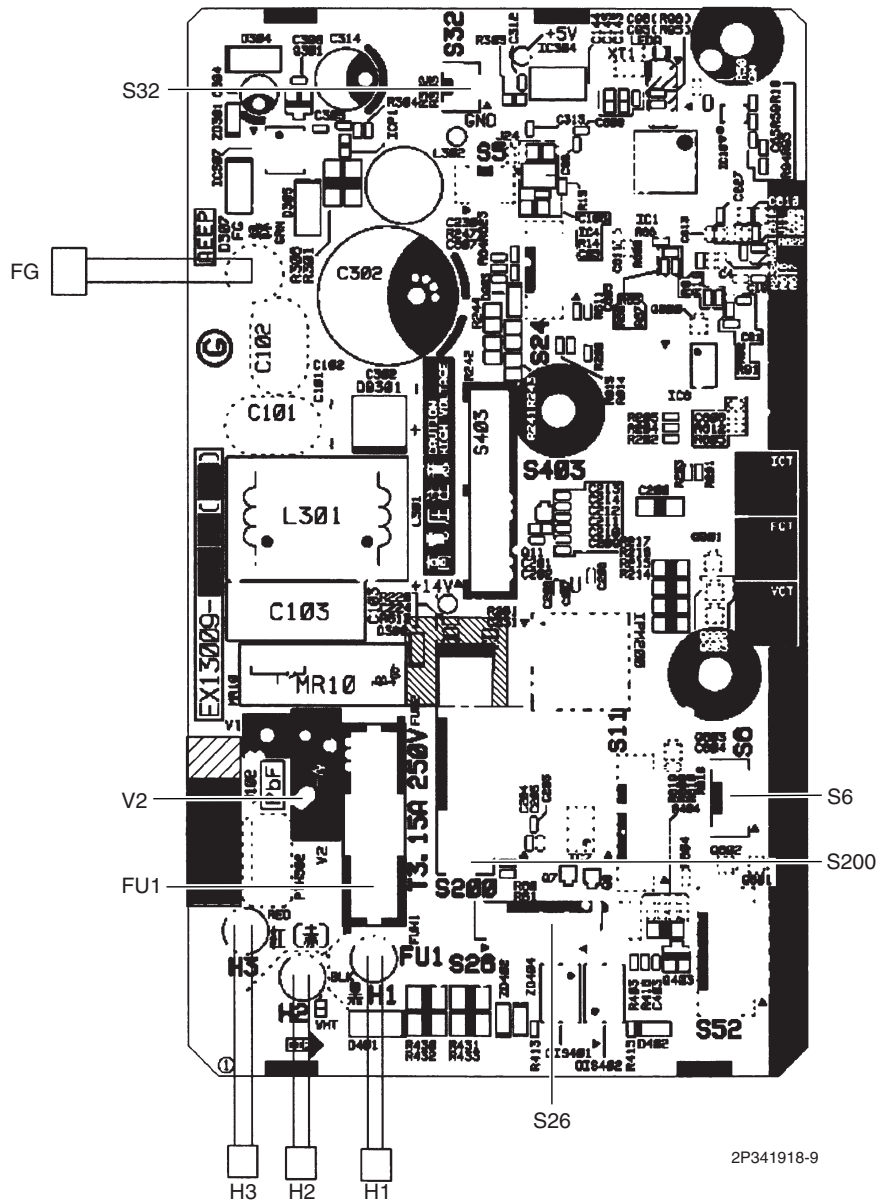

Display PCB (PCB2)

- | | |
|---------------|--|
| 1) S27 | Connector for control PCB |
| 2) SW1 (S1W) | Forced cooling operation ON/OFF button
* Refer to page 91 for details. |
| 3) LED1 (H1P) | LED for operation (green) |
| 4) LED2 (H2P) | LED for timer (yellow) |
| 5) RTH1 (R1T) | Room temperature thermistor |

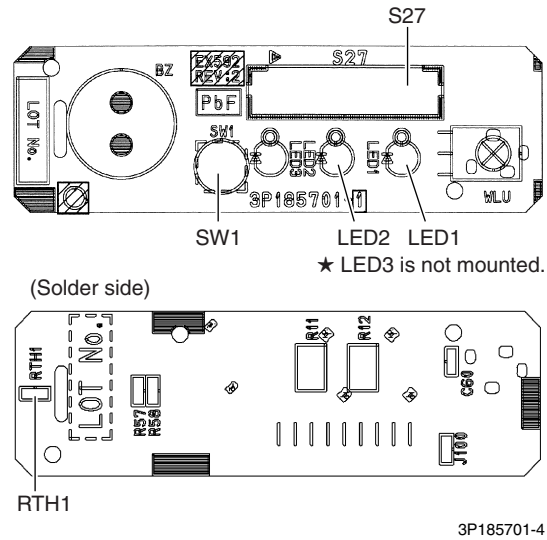

Note: The symbols in the parenthesis are the names on the appropriate wiring diagram.

Remote Control PCB (BR069)

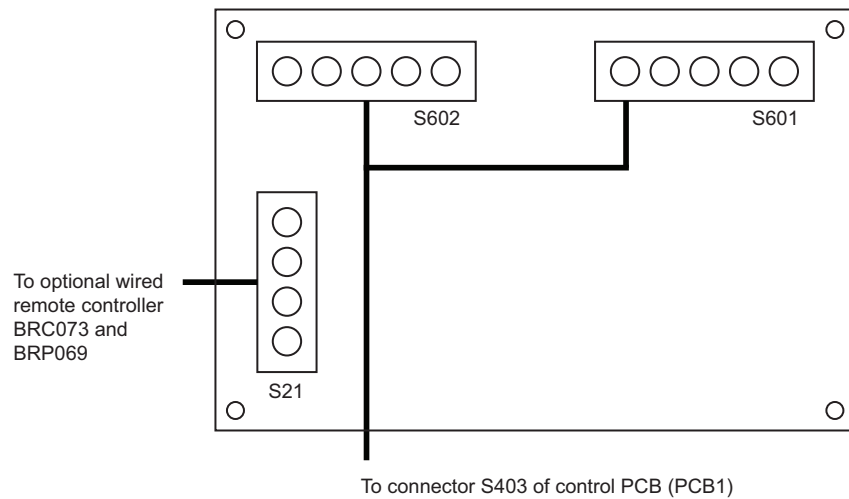

1.2 50/60/71 Class

Control PCB (PCB2)

- 1) S6 Connector for swing motor (horizontal blade)
- 2) S26 Connector for display PCB
- 3) S32 Connector for indoor heat exchanger thermistor
- 4) S200 Connector for DC fan motor
- 5) S900 Connector for filter PCB

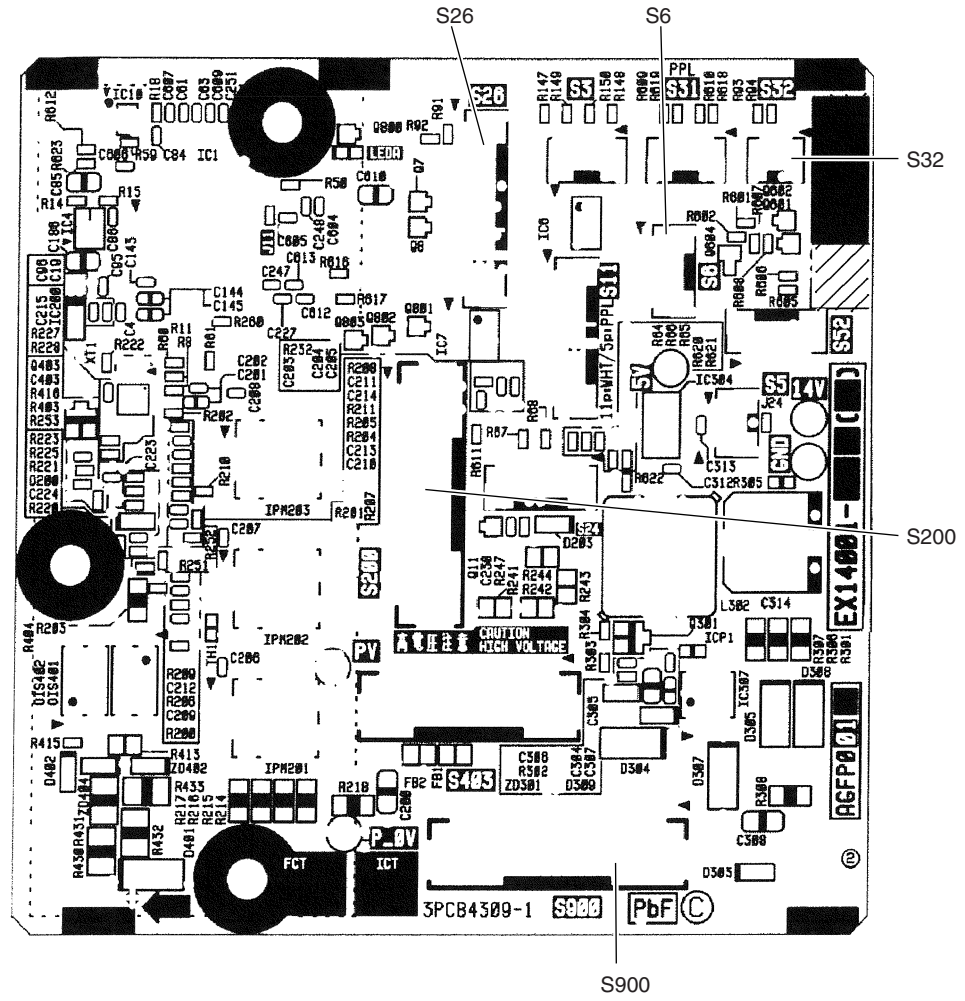

**Filter PCB
(PCB1)**

- 1) S100 Connector for terminal board
- 2) S800 Connector for control PCB
- 3) FG, HE Connector for ground
- 4) FU1 Fuse (3.15 A, 250 V)
- 5) V2 Varistor

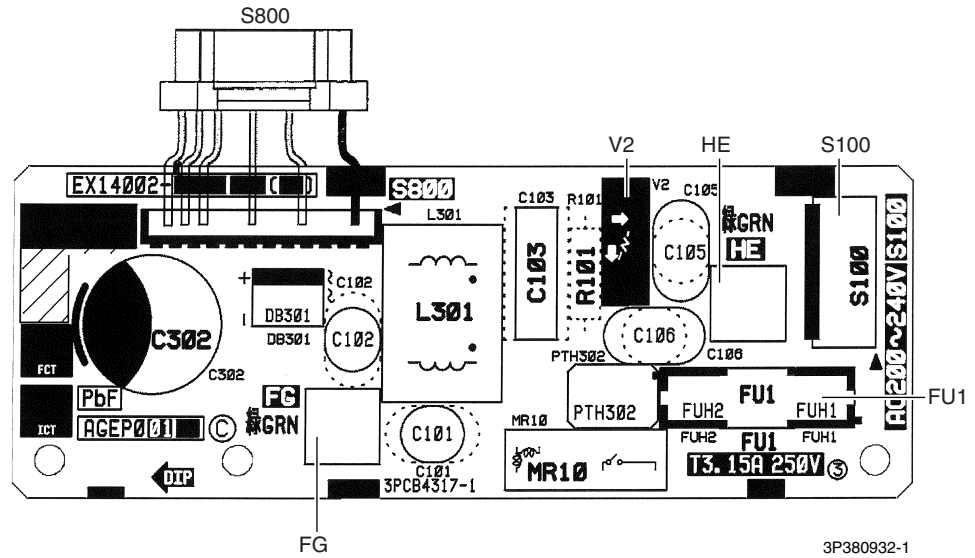

**Display PCB
(PCB3)**

- 1) S27 Connector for control PCB
- 2) SW1 (S1W) Forced cooling operation **ON/OFF** button
* Refer to page 91 for details.
- 3) LED1 (H1P) LED for operation (green)
- 4) LED2 (H2P) LED for timer (yellow)
- 5) RTH1 (R1T) Room temperature thermistor

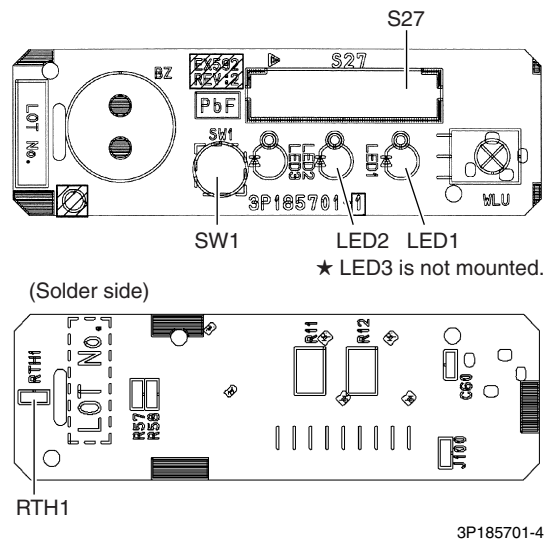

Note: The symbols in the parenthesis are the names on the appropriate wiring diagram.

Remote Control
PCB (BR069)

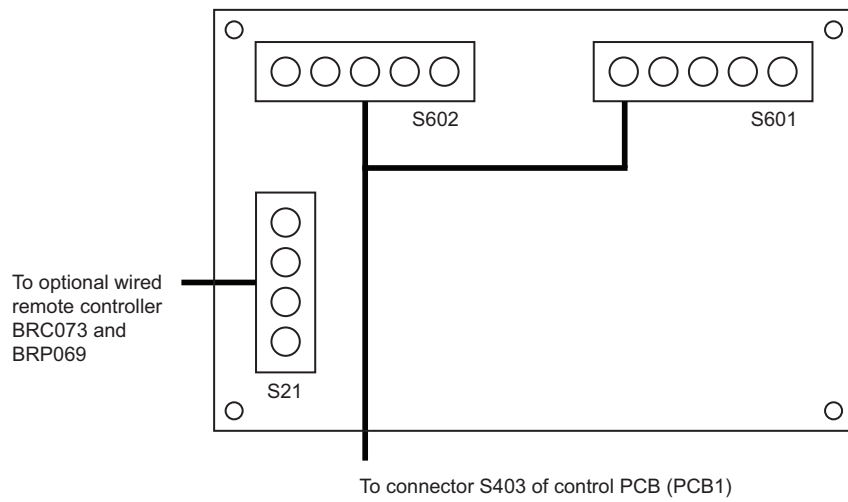

2. Outdoor Unit

2.1 20/25/35 Class

Main PCB (PCB1)

- | | |
|------------------|---|
| 1) S20 | Connector for electronic expansion valve coil |
| 2) S30 | Connector for compressor motor |
| 3) S40 | Connector for overload protector |
| 4) S71 | Connector for DC fan motor |
| 5) S80 | Connector for four way valve coil |
| 6) S90 | Connector for thermistors |
| | (outdoor temperature, outdoor heat exchanger, discharge pipe) |
| 7) E1, E2 | Terminal for earth wire |
| 8) HL1, HN1, S | Connector for terminal board |
| 9) HR1, HR2 | Connector for reactor |
| 10) FU1, FU2 | Fuse (3.15 A, 250 V) |
| 11) FU3 | Fuse (20 A, 250 V) |
| 12) LED A | LED for service monitor (green) |
| 13) V2, V3, V150 | Varistor |

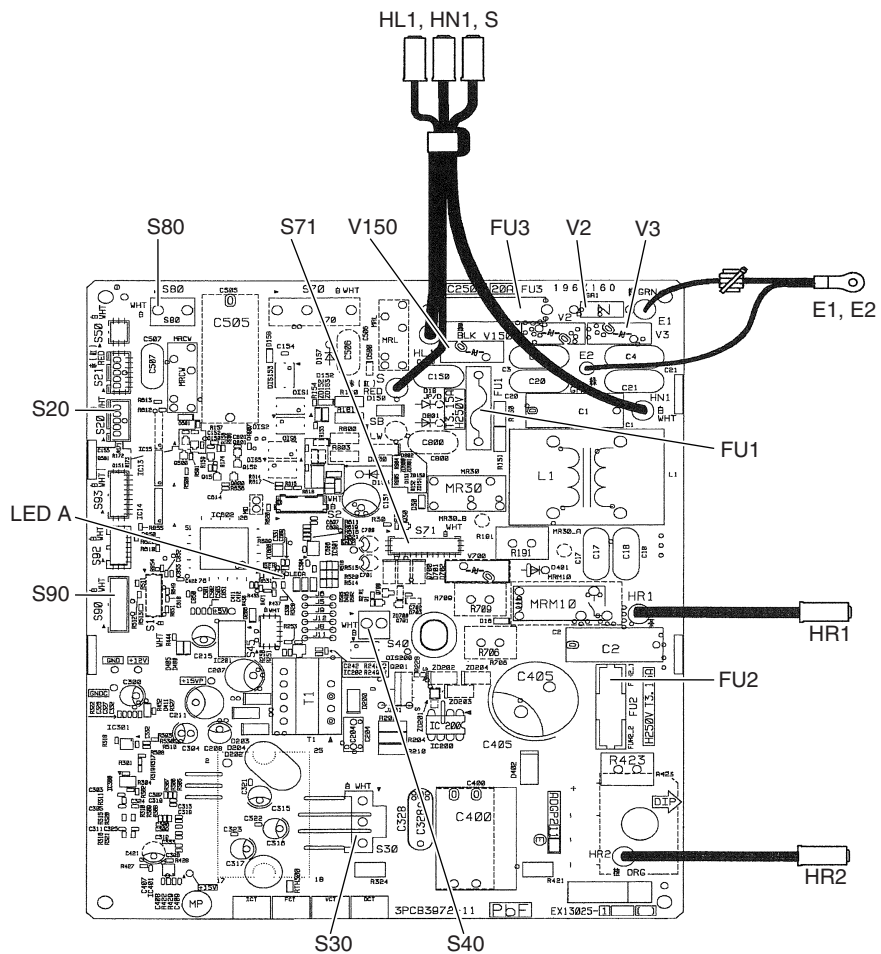

2P383853-1

2.2 50/60/71 class

Main PCB

- | | |
|----------------|---|
| 1) S20 | Connector for electronic expansion valve coil |
| 2) S40 | Connector for overload protector |
| 3) S70 | Connector for DC fan motor |
| 4) S80 | Connector for four way valve coil (heat pump model only) |
| 5) S90 | Connector for thermistors (outdoor temperature, outdoor heat exchanger, discharge pipe) |
| 6) HL1, HN1, S | Connector for terminal board |
| 7) E1, E2 | Terminal for ground |
| 8) U, V, W | Connector for compressor |
| 9) FU1, FU2 | Fuse (3.15 A, 250 V) |
| 10)FU3 | Fuse (30 A, 250 V) |
| 11)LED A | LED for service monitor (green) |
| 12)V1, V2, V3 | Varistor |

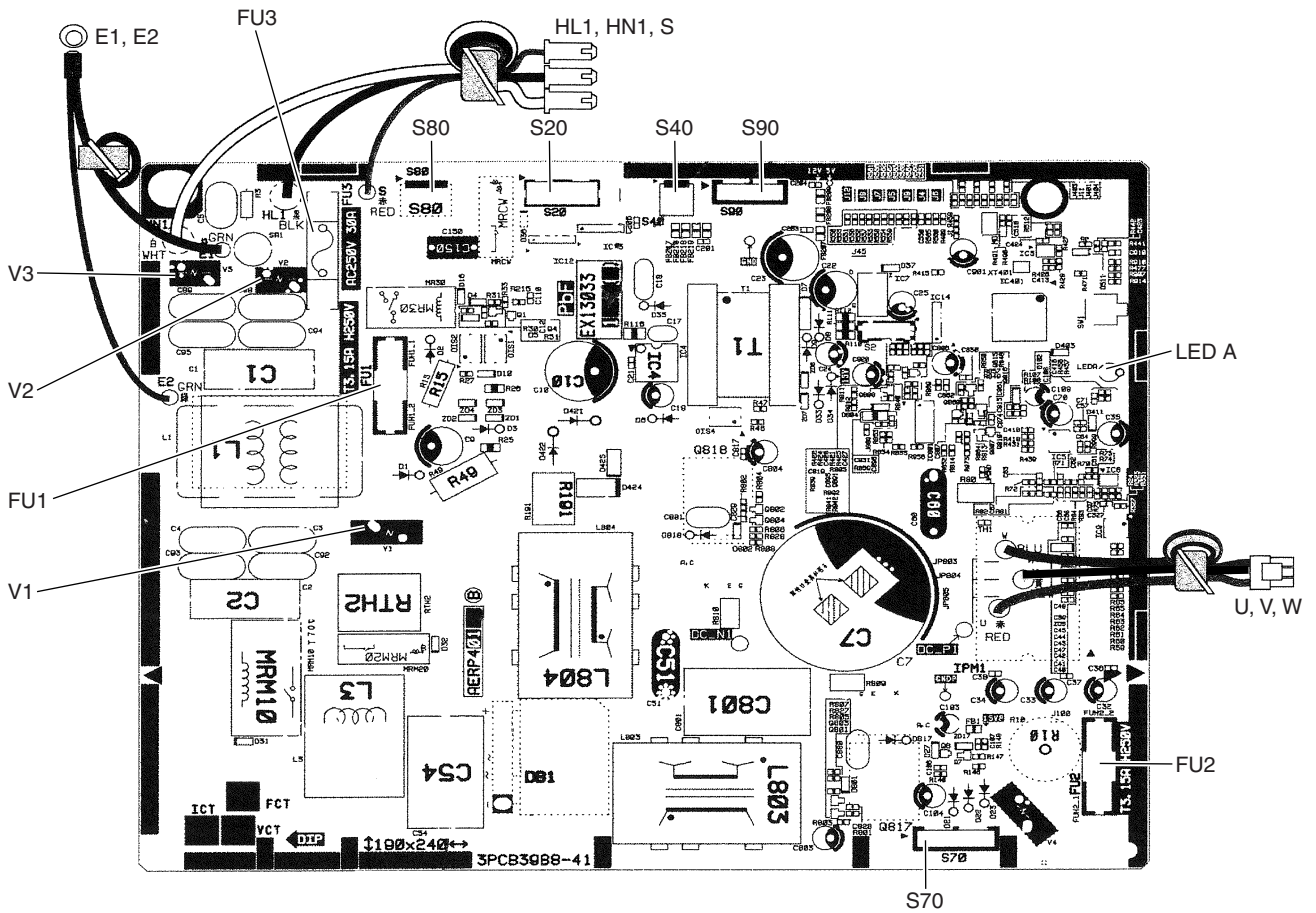

2P382390-12

Part 4

Functions and Control

1. Main Functions.....	15
1.1 Temperature Control	15
1.2 Frequency Principle.....	15
1.3 Airflow Direction Control.....	17
1.4 Fan Speed Control for Indoor Unit	18
1.5 Program Dry Operation	19
1.6 Automatic Operation.....	20
1.7 Thermostat Control.....	21
1.8 NIGHT SET Mode	22
1.9 ECONO Operation	22
1.10 Inverter POWERFUL Operation	23
1.11 Other Functions.....	24
2. Thermistor Functions	25
3. Control Specification	26
3.1 Mode Hierarchy	26
3.2 Frequency Control.....	27
3.3 Controls at Mode Changing / Start-up.....	29
3.4 Discharge Pipe Temperature Control.....	31
3.5 Input Current Control.....	32
3.6 Freeze-up Protection Control	33
3.7 Heating Peak-cut Control	33
3.8 Outdoor Fan Control.....	34
3.9 Liquid Compression Protection Function.....	34
3.10 Defrost Control	35
3.11 Electronic Expansion Valve Control	36
3.12 Malfunctions	39

1. Main Functions

1.1 Temperature Control

Definitions of Temperatures

The definitions of temperatures are classified as following.

- ◆ Room temperature: temperature of lower part of the room
- ◆ Set temperature: temperature set by remote controller
- ◆ Room thermistor temperature: temperature detected by room temperature thermistor
- ◆ Target temperature: temperature determined by microcomputer

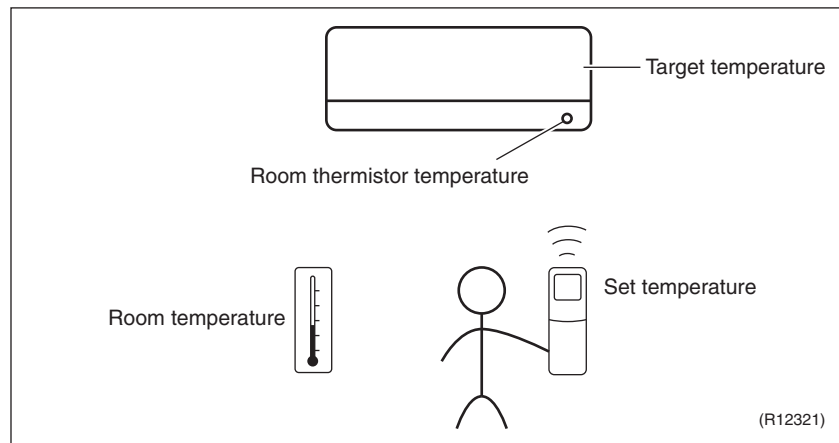

Temperature Control

The temperature of the room is detected by the room temperature thermistor. However, there is a difference between the temperature detected by room temperature thermistor and the temperature of lower part of the room, depending on the type of the indoor unit or installation condition. Practically, the temperature control is done by the target temperature appropriately adjusted for the indoor unit and the temperature detected by room temperature thermistor.

1.2 Frequency Principle

Control Parameters

The frequency of the compressor is controlled by the following 2 parameters:

- The load condition of the operating indoor unit
- The difference between the room thermistor temperature and the target temperature

The target frequency is adapted by additional parameters in the following cases:

- Frequency restrictions
- Initial settings
- Forced cooling operation

Inverter Principle

To regulate the capacity, a frequency control is needed. The inverter makes it possible to control the rotation speed of the compressor. The following table explains the conversion principle:

Phase	Description
1	The supplied AC power source is converted into the DC power source for the present.
2	The DC power source is reconverted into the three phase AC power source with variable frequency. <ul style="list-style-type: none"> ■ When the frequency increases, the rotation speed of the compressor increases resulting in an increase of refrigerant circulation. This leads to a larger amount of heat exchange per unit. ■ When the frequency decreases, the rotation speed of the compressor decreases resulting in a decrease of refrigerant circulation. This leads to a smaller amount of heat exchange per unit.

The following drawing shows a schematic view of the inverter principle:

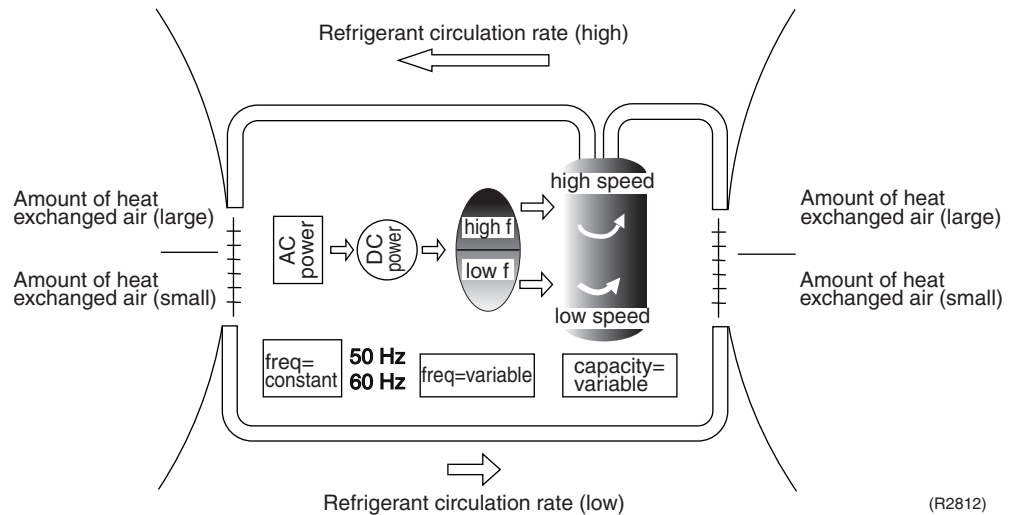

Inverter Features

The inverter provides the following features:

- The regulating capacity can be changed according to the changes in the outdoor temperature and cooling / heating load.
- Quick heating and quick cooling
The rotation speed of the compressor is increased when starting the heating (or cooling). This enables to reach the set temperature quickly.
- Even during extreme cold weather, high capacity is achieved. It is maintained even when the outdoor temperature is 2°C.
- Comfortable air conditioning
A fine adjustment is integrated to keep the room temperature constant.
- Energy saving heating and cooling
Once the set temperature is reached, the energy saving operation enables to maintain the room temperature at low power.

Frequency Limits

The following functions regulate the minimum and maximum frequency:

Frequency	Functions
Low	<ul style="list-style-type: none"> ■ Four way valve operation compensation. Refer to page 30.
High	<ul style="list-style-type: none"> ■ Compressor protection function. Refer to page 30. ■ Discharge pipe temperature control. Refer to page 31. ■ Input current control. Refer to page 32. ■ Freeze-up protection control. Refer to page 33. ■ Heating peak-cut control. Refer to page 33. ■ Defrost control. Refer to page 35.

Forced Cooling Operation

Refer to page 91 for details.

1.3 Airflow Direction Control

Power-Airflow Flap

The large flap sends a large volume of air downward to the floor and provides an optimum control in cooling, dry, and heating operation.

Cooling / Dry

During cooling or dry operation, the flap retracts into the indoor unit. Then, cool air can be blown far and distributed all over the room.

Heating

During heating operation, the large flap directs airflow downward to spread the warm air to the entire room.

Wide-Angle Louvers

The louvers, made of elastic synthetic resin, provide a wide range of airflow that guarantees comfortable air distribution.

Auto-Swing

The following table explains the auto-swing process for cooling, dry, heating, and fan:

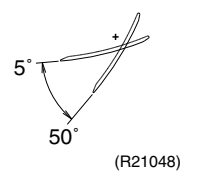
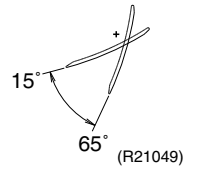
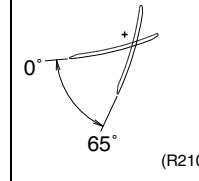
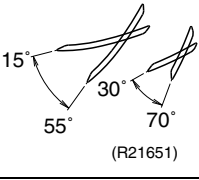
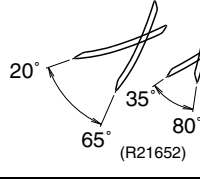
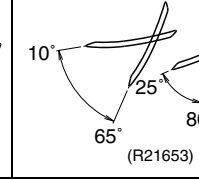
	Flap (up and down)		
	Cooling / Dry	Heating	Fan
20/25/35 class			
50/60/71 class			

COMFORT AIRFLOW Operation

The flap is controlled not to blow the air directly at the people in the room.

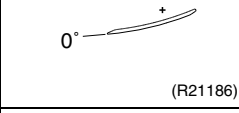
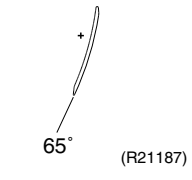
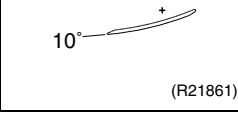
	Cooling	Heating
20/25/35 class		
50/60/71 class		

1.4 Fan Speed Control for Indoor Unit

Outline

Phase control and fan speed control contains 9 steps: LLL, LL, SL, L, ML, M, MH, H, and HH. The airflow rate can be automatically controlled depending on the difference between the room thermistor temperature and the target temperature.

Automatic Fan Speed Control

In automatic fan speed control, the step SL is not available.

Step	Cooling	Heating
LLL		
LL		
L		
ML		
M		
MH		
H		
HH (POWERFUL)		

↔ = The airflow rate is automatically controlled within this range when the **FAN** setting button is set to automatic.

Cooling

The following drawing explains the principle of fan speed control for cooling.

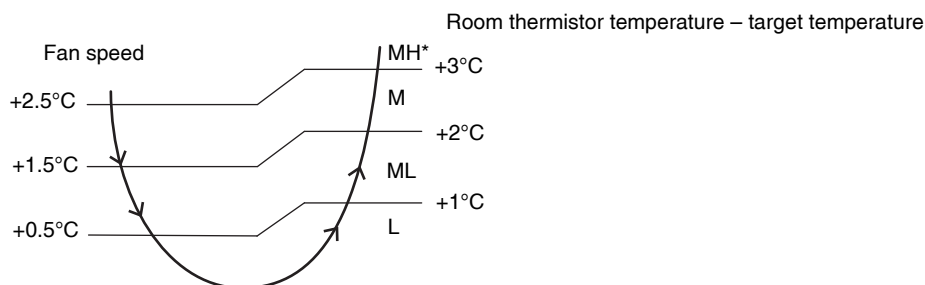

(R14588)

*The upper limit is M tap in 30 minutes from the operation start.

Heating

In heating operation, the fan speed is regulated according to the indoor heat exchanger temperature and the difference between the room thermistor temperature and the target temperature.

COMFORT AIRFLOW Operation

- The fan speed is controlled automatically.
- The latest command has the priority between POWERFUL and COMFORT AIRFLOW.

1.5 Program Dry Operation

Outline Program dry operation removes humidity while preventing the room temperature from lowering. Since the microcomputer controls both the temperature and airflow rate, the temperature adjustment and **FAN** setting buttons are inoperable.

Detail The microcomputer automatically sets the temperature and airflow rate. The difference between the room thermistor temperature at start-up and the target temperature is divided into two zones. Then, the unit operates in an appropriate capacity for each zone to maintain the temperature and humidity at a comfortable level.

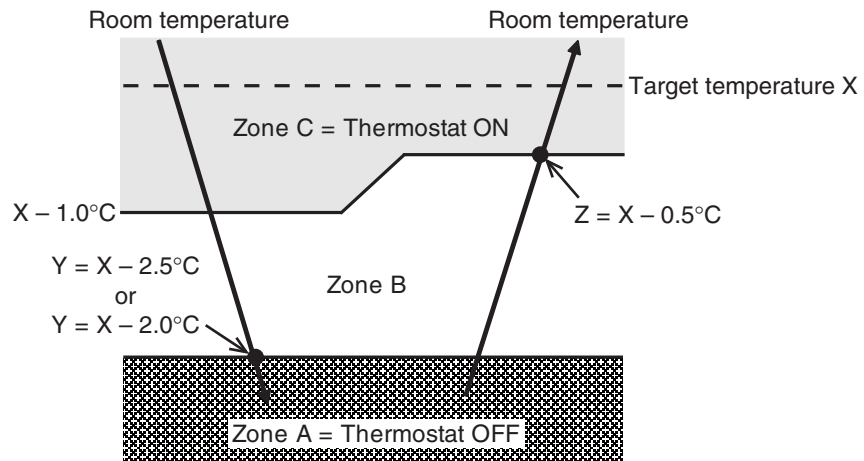

(R22443)

Room thermistor temperature at start-up	Target temperature X	Thermostat OFF point Y	Thermostat ON point Z ★
24°C or more	Room thermistor temperature at start-up	$X - 2.5^{\circ}\text{C}$	$X - 0.5^{\circ}\text{C}$
18 ~ 23.5°C		$X - 2.0^{\circ}\text{C}$	$X - 0.5^{\circ}\text{C}$
17.5°C or less	18°C	$X - 2.0^{\circ}\text{C} = 16^{\circ}\text{C}$	$X - 0.5^{\circ}\text{C} = 17.5^{\circ}\text{C}$

★ Thermostat turns on also when the room temperature is in the zone B for 10 minutes.

1.6 Automatic Operation

Outline

Automatic Cooling / Heating Function

When the automatic operation is selected with the remote controller, the microcomputer automatically determines the operation mode as cooling or heating according to the room temperature and the set temperature at start-up.

The unit automatically switches the operation mode to maintain the room temperature at the set temperature.

Detail

Ts: set temperature (set by remote controller)

Tt: target temperature (determined by microcomputer)

Tr: room thermistor temperature (detected by room temperature thermistor)

C: correction value

- The set temperature (Ts) determines the target temperature (Tt).
(Ts = 18 ~ 30°C).
- The target temperature (Tt) is calculated as;
 $Tt = Ts + C$
where C is the correction value.
C = 0°C
- Thermostat ON/OFF point and operation mode switching point are as follows.
Tr means the room thermistor temperature.
 - Heating → Cooling switching point:
 $Tr \geq Tt + 3.0^\circ\text{C}$
 - Cooling → Heating switching point:
 $Tr < Tt - 3.0^\circ\text{C}$
 - Thermostat ON/OFF point is the same as the ON/OFF point of cooling or heating operation.
- During initial operation
 - $Tr \geq Ts$: Cooling operation
 - $Tr < Ts$: Heating operation

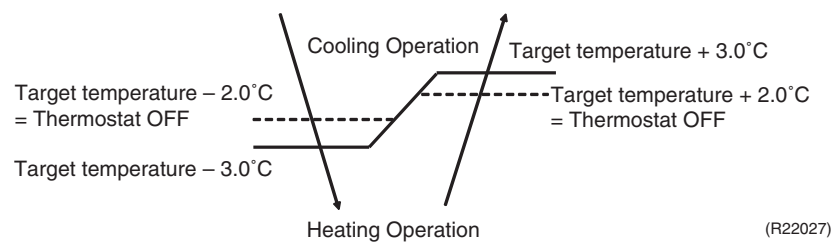

Ex: When the target temperature is 25°C

Cooling → 23°C: Thermostat OFF → 22°C: Switch to heating

Heating → 27°C: Thermostat OFF → 28°C: Switch to cooling

1.7 Thermostat Control

Outline Thermostat control is based on the difference between the room thermistor temperature and the target temperature.

Detail

Thermostat OFF Condition

- ♦ The temperature difference is in the zone A.

Thermostat ON Conditions

- ♦ The temperature difference returns to the zone C after being in the zone A.
- ♦ The system resumes from defrost control in any zones except A.
- ♦ The operation turns on in any zones except A.
- ♦ The monitoring time has passed while the temperature difference is in the zone B.
(Cooling: 10 minutes, Dry: 7.5 minutes, Heating: 10 seconds)

Cooling/Dry

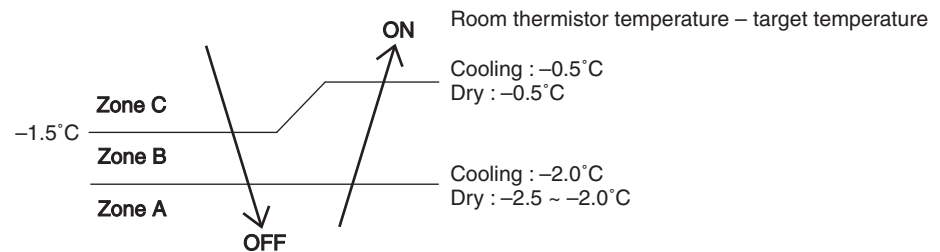

(R22110)

Heating

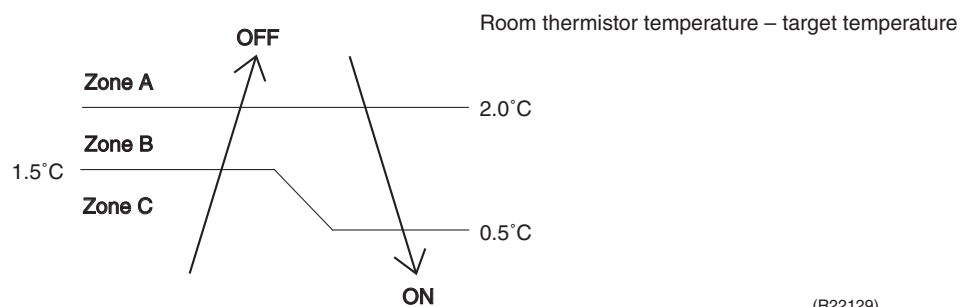

(R22129)



Refer to Temperature Control on page 15 for details.

1.8 NIGHT SET Mode

Outline When the OFF TIMER is set, NIGHT SET Mode is automatically activated. NIGHT SET Mode keeps the airflow rate setting.

Detail NIGHT SET Mode continues operation at the target temperature for the first one hour, then automatically raises the target temperature slightly in cooling, or lowers it slightly in heating. This prevents excessive cooling in summer and excessive heating in winter to ensure comfortable sleeping conditions, and also conserves electricity.

Cooling

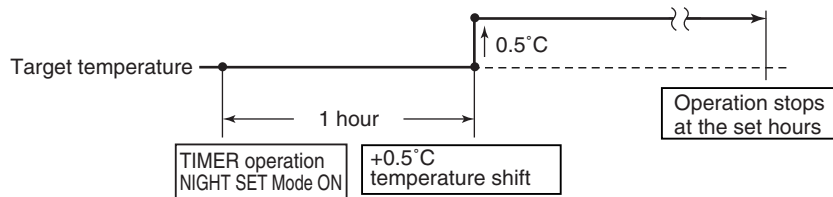

(R22018)

Heating

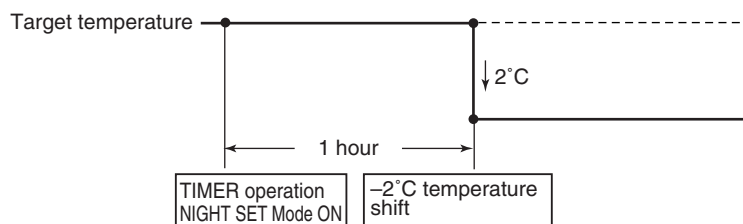

(R22029)

1.9 ECONO Operation

Outline ECONO operation reduces the maximum power consumption. This operation is particularly convenient for energy-saving. It is also a major bonus when breaker capacity does not allow the use of multiple electrical devices and air conditioners. It can be easily activated by pushing the **ECONO** button on the wireless remote controller.

Detail

- When this function is activated, the maximum capacity also decreases.
- The remote controller can send the ECONO command when the unit is in cooling, heating, dry, or automatic operation. This function can only be set when the unit is running. Press the **ON/OFF** button on the remote controller to cancel the function.
- This function and POWERFUL operation cannot be used at the same time. The latest command has the priority.

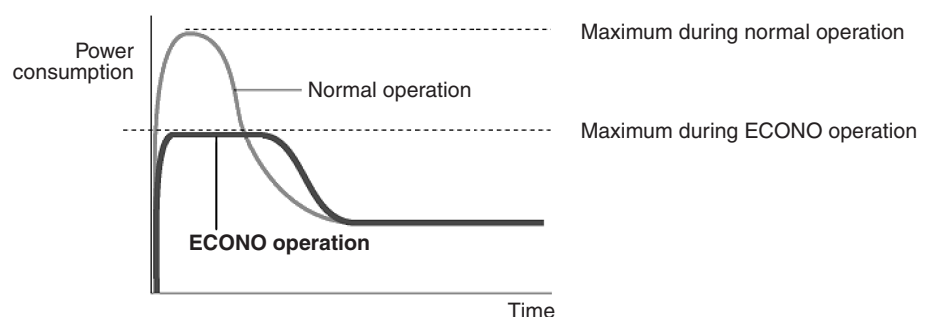

(R21051)

1.10 Inverter POWERFUL Operation

Outline

In order to exploit the cooling and heating capacity to full extent, the air conditioner can be operated by increasing the indoor fan rotating speed and the compressor frequency.

Detail

When the **POWERFUL** button is pressed, the fan speed and target temperature are converted to the following states for 20 minutes.

Operation mode	Fan speed	Target temperature
COOL	H tap + A rpm	18°C
DRY	Dry rotating speed + A rpm	Lowered by 2.5°C
HEAT	H tap + A rpm	31°C
FAN	H tap + A rpm	—
AUTO	Same as cooling / heating in POWERFUL operation	The target temperature is kept unchanged.

A = 20/25/35 class: 80 rpm
50/60/71 class: 50 rpm

Ex: POWERFUL operation in cooling.

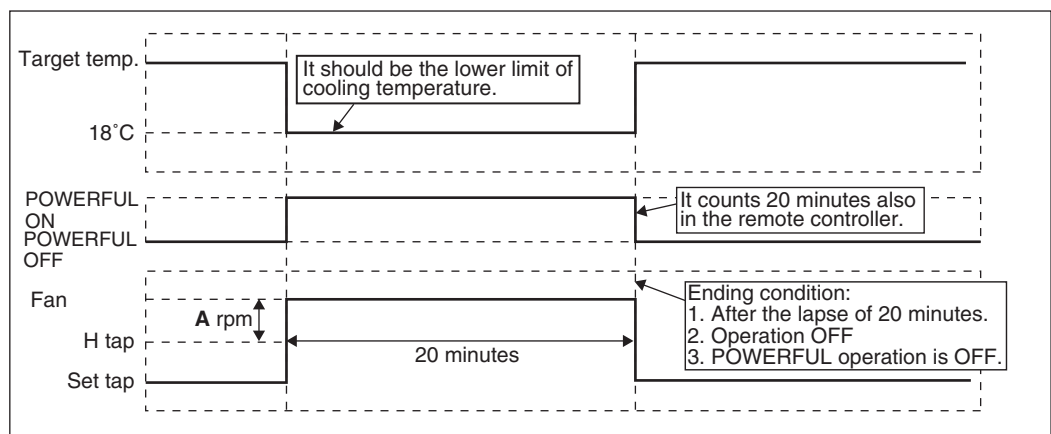

(R19177)



Note: POWERFUL operation cannot be used together with ECONO or COMFORT AIRFLOW operation.

1.11 Other Functions

1.11.1 Hot-Start Function

In order to prevent the cold air blast that normally occurs when heating operation is started, the temperature of the indoor heat exchanger is detected, and the airflow is either stopped or significantly weakened resulting in comfortable heating.



Note: The cold air blast is prevented using similar control when defrost control starts or when the thermostat is turned ON.

1.11.2 Signal Receiving Sign

When the indoor unit receives a signal from the remote controller, the unit emits a signal receiving sound.

1.11.3 Indoor Unit ON/OFF Button

An **ON/OFF** button is provided on the display of the unit.

- Press the **ON/OFF** button once to start operation. Press once again to stop it.
- The **ON/OFF** button is useful when the remote controller is missing or the battery has run out.

Operation mode	Temperature setting	Airflow rate
AUTO	25°C	Automatic

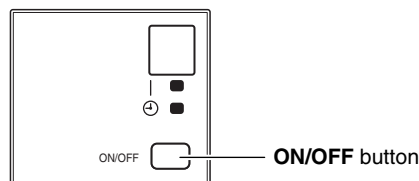

(R21052)

Forced cooling operation

Forced cooling operation can be started by pressing the **ON/OFF** button for 5 ~ 9 seconds while the unit is not operating.

Refer to page 91 for details.



Note: When the **ON/OFF** button is pressed for 10 seconds or more, the forced cooling operation is stopped.

1.11.4 Auto-restart Function

If a power failure (including one for just a moment) occurs during the operation, the operation restarts automatically when the power is restored in the same condition as before the power failure.



Note: It takes 3 minutes to restart the operation because the 3-minute standby function is activated.

2. Thermistor Functions

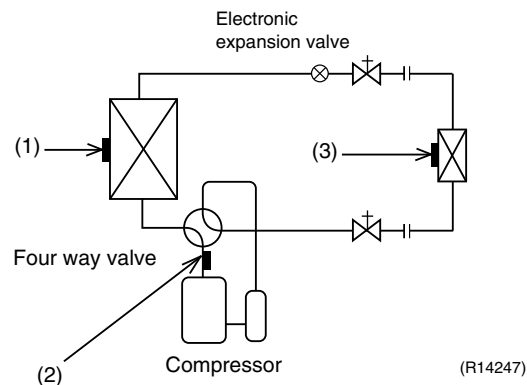

(1) Outdoor Heat Exchanger Thermistor

1. The outdoor heat exchanger thermistor is used for controlling the target discharge pipe temperature. The system sets the target discharge pipe temperature according to the outdoor and indoor heat exchanger temperature, and controls the electronic expansion valve opening so that the target discharge pipe temperature can be obtained.
2. In cooling operation, the outdoor heat exchanger thermistor is used for detecting the disconnection of the discharge pipe thermistor. When the discharge pipe temperature drops below the outdoor heat exchanger temperature by more than a certain value, the discharge pipe thermistor is judged as disconnected.
3. In cooling operation, the outdoor heat exchanger thermistor is used for high pressure protection.

(2) Discharge Pipe Thermistor

1. The discharge pipe thermistor is used for controlling discharge pipe temperature. If the discharge pipe temperature (used in place of the inner temperature of the compressor) rises abnormally, the operating frequency becomes lower or the operation halts.
2. The discharge pipe thermistor is used for detecting disconnection of the discharge pipe thermistor.

(3) Indoor Heat Exchanger Thermistor

1. The indoor heat exchanger thermistor is used for controlling the target discharge pipe temperature. The system sets the target discharge pipe temperature according to the outdoor and indoor heat exchanger temperature, and controls the electronic expansion valve opening so that the target discharge pipe temperature can be obtained.
2. In cooling operation, the indoor heat exchanger thermistor is used for freeze-up protection control. If the indoor heat exchanger temperature drops abnormally, the operating frequency becomes lower or the operation halts.
3. In heating operation, the indoor heat exchanger thermistor is used for detecting the disconnection of the discharge pipe thermistor. When the discharge pipe temperature drops below the indoor heat exchanger temperature by more than a certain value, the discharge pipe thermistor is judged as disconnected.

3. Control Specification

3.1 Mode Hierarchy

Outline

The air conditioner control has normal operation mode, forced operation mode, and power transistor test mode for installation and servicing.

Detail

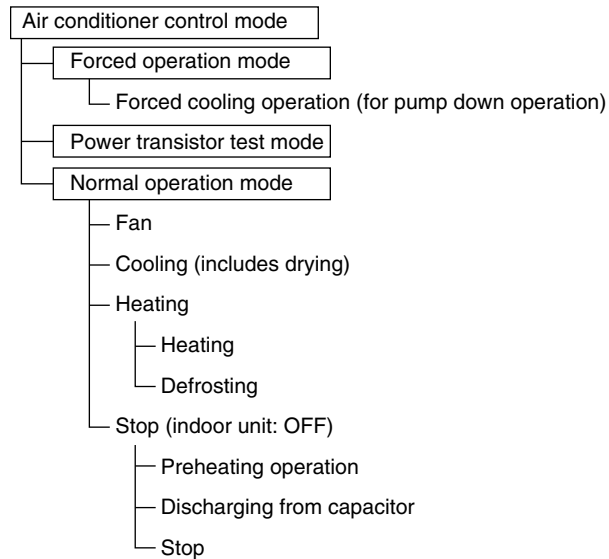

(R19522)



Note: Unless specified otherwise, a dry operation command is regarded as cooling operation.

3.2 Frequency Control

Outline

The compressor frequency is determined according to the difference between the room thermistor temperature and the target temperature.

When the shift of the frequency is less than zero ($\Delta F < 0$) by PI control, the target frequency is used as the command frequency.

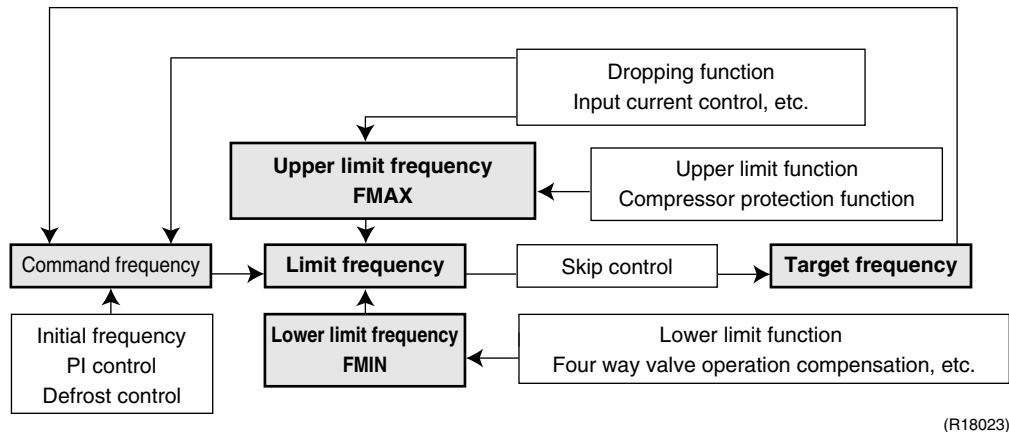

Detail

1. Determine command frequency

Command frequency is determined in the following order of priority.

1. Limiting defrost control time
2. Forced cooling
3. Indoor frequency command

2. Determine upper limit frequency

The minimum value is set as an upper limit frequency among the frequency upper limits of the following functions:

Compressor protection, input current, discharge pipe temperature, heating peak-cut, freeze-up protection, defrost.

3. Determine lower limit frequency

The maximum value is set as a lower limit frequency among the frequency lower limits of the following functions:

Four way valve operation compensation, draft prevention, pressure difference upkeep.

4. Determine prohibited frequency

There is a certain prohibited frequency such as a power supply frequency.

Initial Frequency

When starting the compressor, the frequency is initialized according to the ΔD value of the indoor unit.

 ΔD signal: Indoor Frequency Command

The difference between the room thermistor temperature and the target temperature is taken as the ΔD value and is used for ΔD signal of frequency command.

Temperature difference	ΔD signal	Temperature difference	ΔD signal	Temperature difference	ΔD signal	Temperature difference	ΔD signal
-2.0	*OFF	0	4	2.0	8	4.0	C
-1.5	1	0.5	5	2.5	9	4.5	D
-1.0	2	1.0	6	3.0	A	5.0	E
-0.5	3	1.5	7	3.5	B	5.5	F

*OFF = Thermostat OFF

PI Control**1. P control**

The ΔD value is calculated in each sampling time (20 seconds), and the frequency is adjusted according to its difference from the frequency previously calculated.

2. I control

If the operating frequency does not change for more than a certain fixed time, the frequency is adjusted according to the ΔD value.

When the ΔD value is low, the frequency is lowered.

When the ΔD value is high, the frequency is increased.

3. Frequency control when other controls are functioning

- ◆ When frequency is dropping;
Frequency control is carried out only when the frequency drops.
- ◆ For controlling lower limit;
Frequency control is carried out only when the frequency rises.

4. Upper and lower limit of frequency by PI control

The frequency upper and lower limits are set according to the command of the indoor unit.

When the indoor or outdoor unit quiet operation command comes from the indoor unit, the upper limit frequency is lower than the usual setting.

3.3 Controls at Mode Changing / Start-up

3.3.1 Preheating Control

Outline The inverter operation in open phase starts with the conditions of the outdoor temperature, the discharge pipe temperature, the radiation fin temperature, and the preheating command from the indoor unit.

Detail Outdoor temperature $\geq -2.5^{\circ}\text{C}$ → Control A (preheating for normal state)
 Outdoor temperature $< -2.5^{\circ}\text{C}$ → Control B (preheating of increased capacity)

Control A

- ◆ ON condition
 - Discharge pipe temperature $< 0^{\circ}\text{C}$
 - Radiation fin temperature $< 85^{\circ}\text{C}$
- ◆ OFF condition
 - Discharge pipe temperature $> 2^{\circ}\text{C}$
 - Radiation fin temperature $\geq 90^{\circ}\text{C}$

Control B

- ◆ ON condition
 - Discharge pipe temperature $< 10^{\circ}\text{C}$
 - Radiation fin temperature $< 85^{\circ}\text{C}$
- ◆ OFF condition
 - Discharge pipe temperature $> 12^{\circ}\text{C}$
 - Radiation fin temperature $\geq 90^{\circ}\text{C}$

3.3.2 Four Way Valve Switching

Outline The four way valve coil is energized / not energized depending on the operation mode. (Heating: ON, Cooling / Dry / Defrost: OFF) In order to eliminate the switching sound as the four way valve coil switches from ON to OFF when the heating is stopped, the OFF delay switch of the four way valve is carried out.

Detail **OFF delay switch of four way valve**
 The four way valve coil is energized for 160 seconds after the operation is stopped.

3.3.3 Four Way Valve Operation Compensation

Outline

At the beginning of operation as the four way valve is switched, the pressure difference to activate the four way valve is acquired when the output frequency is higher than a certain fixed frequency, for a certain fixed time.

Detail

Starting Conditions

1. When the compressor starts and the four way valve switches from OFF to ON
2. When the four way valve switches from ON to OFF during operation
3. When the compressor starts after resetting
4. When the compressor starts after the fault of four way valve switching

The lower limit of frequency keeps **A** Hz for **B** seconds with any conditions 1 through 4 above. When the outdoor temperature is above **C** °C in heating, the frequency decreases depending on the outdoor temperature.

	20/25/35 class		50/60/71 class	
	Cooling	Heating	Cooling	Heating
A (Hz)	62		48	
B (seconds)	50		70	
C (°C)	50		15	

3.3.4 3-Minute Standby

Turning on the compressor is prohibited for 3 minutes after turning it off.
(The function is not activated when defrosting.)

3.3.5 Compressor Protection Function

When turning the compressor from OFF to ON, the upper limit of frequency is set as follows.
(The function is not activated when defrosting.)

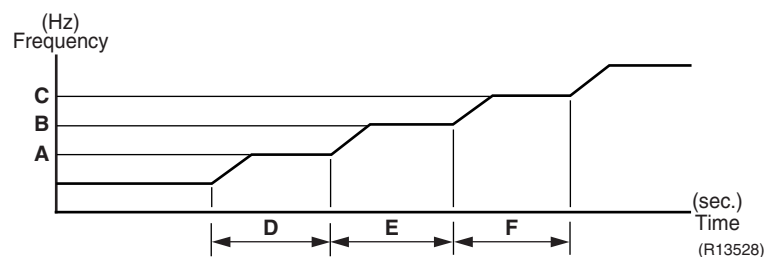

	20/25/35 class	50/60/71 class
A (Hz)	40	52
B (Hz)	54	68
C (Hz)	72	80
D (seconds)	180	300
E (seconds)	420	200
F (seconds)	180	460

3.4 Discharge Pipe Temperature Control

Outline

The discharge pipe temperature is used as the internal temperature of the compressor. If the discharge pipe temperature rises above a certain level, the upper limit of frequency is set to keep the discharge pipe temperature from rising further.

Detail

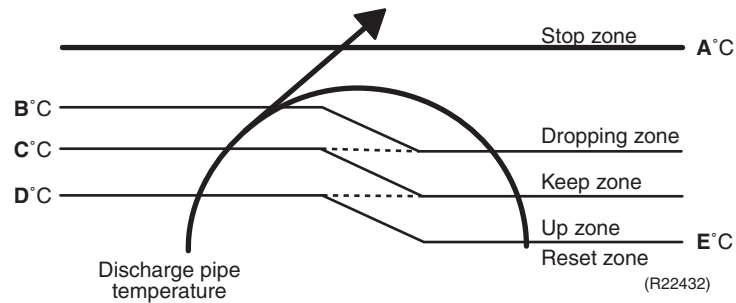

	20/25/35 class	50/60/71 class
A (°C)	110	110
B (°C)	103	103
C (°C)	98	101.5
D (°C)	93	100
E (°C)	88	95

Zone	Control
Stop zone	When the temperature reaches the stop zone, the compressor stops.
Dropping zone	The upper limit of frequency decreases.
Keep zone	The upper limit of frequency is kept.
Up zone	The upper limit of frequency increases.
Reset zone	The upper limit of frequency is canceled.

3.5 Input Current Control

Outline

The microcomputer calculates the input current while the compressor is running, and sets the frequency upper limit based on the input current.

In case of heat pump models, this control is the upper limit control of frequency and takes priority over the lower limit control of four way valve operation compensation.

Detail

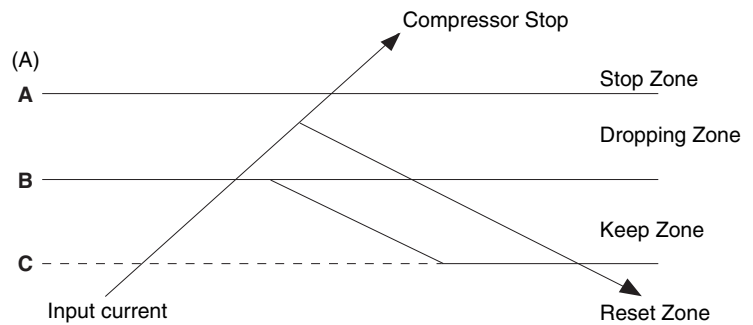

(R14643)

Frequency control in each zone

Stop zone

- After the input current remains in the stop zone for 2.5 seconds, the compressor is stopped.

Dropping zone

- The upper limit of the compressor frequency is defined as operation frequency – 2 Hz.
- After this, the output frequency is lowered by 2 Hz every second until it reaches the keep zone.

Keep zone

- The present maximum frequency goes on.

Reset zone

- Limit of the frequency is canceled.

	20/25 class		35 class		50 class		60/71 class	
	Cooling	Heating	Cooling	Heating	Cooling	Heating	Cooling	Heating
A (A)	14.0		14.0		18		18	
B (A)	6.0	6.75	6.5	7.75	10	10.75	12	11.5
C (A)	5.25	6.0	5.75	7.0	9	9.75	11	10.5

Limitation of current dropping and stop value according to the outdoor temperature

- The current drops when outdoor temperature becomes higher than a certain level (depending on the model).

3.6 Freeze-up Protection Control

During cooling operation, the signal sent from the indoor unit determines the frequency upper limit and prevents freezing of the indoor heat exchanger. (The signal from the indoor unit is divided into zones.)

The operating frequency limitation is judged with the indoor heat exchanger temperature.

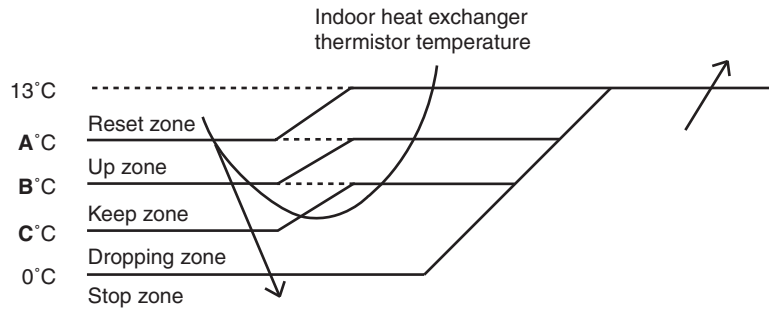

(R22433)

A (°C)	B (°C)	C (°C)
7	5	3

3.7 Heating Peak-cut Control

During heating operation, the indoor heat exchanger temperature determines the frequency upper limit to prevent abnormal high pressure.

The operating frequency limitation is judged with the indoor heat exchanger temperature.

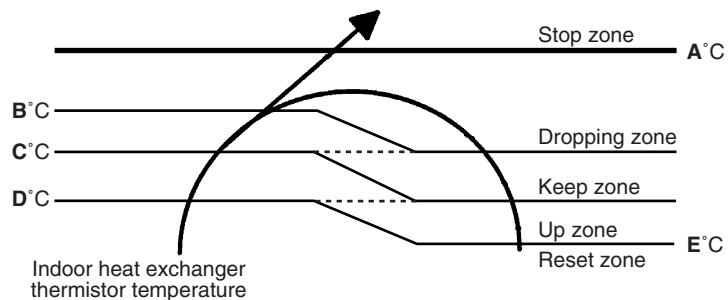

(R22434)

	20/25/35 class	50/60/71 class
A (°C)	65	60
B (°C)	55	54
C (°C)	52	51
D (°C)	50	49
E (°C)	45	44

Zone	Control
Stop zone	When the temperature reaches the stop zone, the compressor stops.
Dropping zone	The upper limit of frequency decreases.
Keep zone	The upper limit of frequency is kept.
Up zone	The upper limit of frequency increases.
Reset zone	The upper limit of frequency is canceled.

3.8 Outdoor Fan Control

1. Fan ON control to cool down the electrical box

The outdoor fan is turned ON when the electrical box temperature is high while the compressor is OFF.

2. Fan OFF control during defrosting

The outdoor fan is turned OFF during defrosting.

3. Fan OFF delay when stopped

The outdoor fan is turned OFF 60-70 seconds after the compressor stops.

4. Fan speed control for pressure difference upkeep

The rotation speed of the outdoor fan is controlled for keeping the pressure difference during cooling operation with low outdoor temperature.

- ◆ When the pressure difference is low, the rotation speed of the outdoor fan is reduced.
- ◆ When the pressure difference is high, the rotation speed of the outdoor fan is controlled as well as normal operation.

5. Fan speed control during forced cooling operation

The outdoor fan is controlled as well as normal operation during forced cooling operation.

6. Fan speed control during POWERFUL operation

The rotation speed of the outdoor fan is increased during POWERFUL operation.

7. Fan speed control during indoor unit quiet operation

The rotation speed of the outdoor fan is reduced by the command of the indoor unit quiet operation.

8. Fan ON/OFF control when operation (cooling, heating, dry) starts / stops

The outdoor fan is turned ON when the operation starts. The outdoor fan is turned OFF when the operation stops.

3.9 Liquid Compression Protection Function

Outline

In order to increase the dependability of the compressor, the compressor is stopped according to the outdoor temperature.

Detail

Operation stops depending on the outdoor temperature.

Compressor turns off under the conditions that the system is in cooling operation and outdoor temperature is below $-12-0^{\circ}\text{C}$ (depending on the model).

3.10 Defrost Control

Outline

Defrosting is carried out by the cooling cycle (reverse cycle). The defrosting time or outdoor heat exchanger temperature must be more than a certain value to finish defrosting.

Detail

Conditions for Starting Defrost

- The starting conditions are determined with the outdoor temperature and the outdoor heat exchanger temperature.
- The system is in heating operation.
- The compressor operates for 6 minutes.
- More than **A** minutes of accumulated time have passed since the start of the operation, or ending the previous defrosting.

Conditions for Canceling Defrost

The judgment is made with the outdoor heat exchanger temperature. (**B**°C)

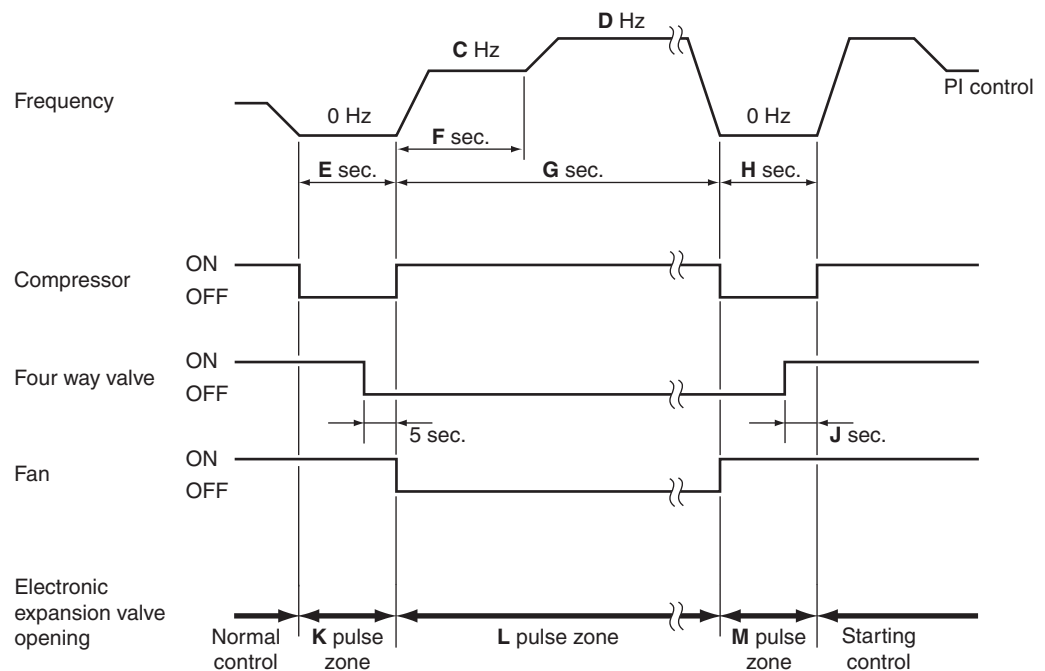

(R23076)

	20/25 class	35 class	50 class	60/71 class
A (minute)	28	28	25	25
B (°C)	4-22	4-22	6-30	6-30
C (Hz)	74★	74★	48	48
D (Hz)	74★	74★	42	42
E (seconds)	80	80	60★	60★
F (seconds)	60	60	60★	60★
G (seconds)	630	630	460	460
H (seconds)	100	70	60	90
J (seconds)	5	5	8	8
K (pulse)	450	450	450	450
L (pulse)	280-380	280-380	300-450	300-450
M (pulse)	450	450	200	200

★: The same value continues.

3.11 Electronic Expansion Valve Control

Outline

The following items are included in the electronic expansion valve control.

Electronic expansion valve is fully closed

1. Electronic expansion valve is fully closed when turning on the power.
2. Pressure equalizing control

Open Control

1. Electronic expansion valve control when starting operation
2. Electronic expansion valve control when the frequency changes
3. Electronic expansion valve control for defrosting
4. Electronic expansion valve control when the discharge pipe temperature is abnormally high
5. Electronic expansion valve control when the discharge pipe thermistor is disconnected

Feedback Control

Target discharge pipe temperature control

Detail

The followings are the examples of electronic expansion valve control which function in each operation mode.

	Power on ; Compressor stop	Operation start	Frequency change under starting control	During target discharge pipe temperature control	Frequency change under target discharge pipe temperature control	Discharge pipe thermistor disconnection	Frequency change under discharge pipe thermistor disconnection control	During defrost control
Starting operation control	—	●	—	—	—	—	—	—
Control when the frequency changes	—	—	●	—	●	—	—	—
Target discharge pipe temperature control	—	—	—	●	—	—	—	—
Discharge pipe thermistor disconnection control	—	—	—	—	—	●	●	—
High discharge pipe temperature control	—	●	●	●	●	—	—	—
Defrost control (heating only)	—	—	—	—	—	—	—	●
Pressure equalizing control	●	—	—	—	—	—	—	—
Opening limit control	—	●	●	●	●	●	●	—

● : Available

— : Not available

3.11.1 Fully Closing with Power ON

The electronic expansion valve is initialized when turning on the power. The opening position is set and the pressure is equalized.

3.11.2 Pressure Equalizing Control

When the compressor is stopped, the pressure equalizing control is activated. The electronic expansion valve opens and the pressure is equalized.

3.11.3 Opening Limit Control

The maximum and minimum opening of the electronic expansion valve are limited.

	20/25/35 class	50/60/71 class
Maximum opening (pulse)	470	480
Minimum opening (pulse)	52	52

The electronic expansion valve is fully closed when cooling operation stops, and is controlled at a fixed opening during defrosting.

3.11.4 Starting Operation Control

The electronic expansion valve opening is controlled when the operation starts, thus preventing superheating or liquid compression.

3.11.5 Control when the Frequency Changes

When the target discharge pipe temperature control is active, if the target frequency changes to a specified value in a certain time period, the target discharge pipe temperature control is canceled and the target opening of the electronic expansion valve is changed according to the frequency shift.

3.11.6 High Discharge Pipe Temperature Control

When the compressor is operating, if the discharge pipe temperature exceeds a certain value, the electronic expansion valve opens and the refrigerant runs to the low pressure side. This procedure lowers the discharge pipe temperature.

3.11.7 Discharge Pipe Thermistor Disconnection Control

Outline

The disconnection of the discharge pipe thermistor is detected by comparing the discharge pipe temperature with the condensation temperature. If the discharge pipe thermistor is disconnected, the electronic expansion valve opens according to the outdoor temperature and the operation frequency, operates for a specified time, and then stops.

After 3 minutes, the operation restarts and checks if the discharge pipe thermistor is disconnected. If the discharge pipe thermistor is disconnected, the system stops after operating for a specified time.

If the disconnection is detected repeatedly, the system is shut down. When the compressor runs for 60 minutes without any error, the error counter is reset.

Detail

Determining thermistor disconnection

When the starting control finishes, the detection timer for disconnection of the discharge pipe thermistor (**A** seconds) starts. When the timer is over, the following adjustment is made.

1. When the operation mode is cooling

When the following condition is fulfilled, the discharge pipe thermistor disconnection is ascertained.

Discharge pipe temperature + 6°C < outdoor heat exchanger temperature

2. When the operation mode is heating

When the following condition is fulfilled, the discharge pipe thermistor disconnection is ascertained.

Discharge pipe temperature + 6°C < indoor heat exchanger temperature

	20/25/35 class	50/60/71 class
A (seconds)	720	540

When the thermistor is disconnected

When the disconnection is ascertained, the compressor continues operation for 9 minutes and then stops.

If the compressor stops repeatedly, the system is shut down.

3.11.8 Target Discharge Pipe Temperature Control

The target discharge pipe temperature is obtained from the indoor and outdoor heat exchanger temperature, and the electronic expansion valve opening is adjusted so that the actual discharge pipe temperature becomes close to the target discharge pipe temperature. (Indirect SH (superheating) control using the discharge pipe temperature)

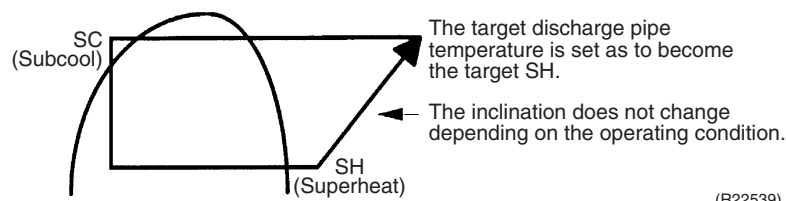

(R22539)

The electronic expansion valve opening and the target discharge pipe temperature are adjusted every 20 seconds. The opening degree of the electronic expansion valve is adjusted by the followings.

- ◆ Target discharge pipe temperature
- ◆ Actual discharge pipe temperature
- ◆ Previous discharge pipe temperature

3.12 Malfunctions

3.12.1 Sensor Malfunction Detection

Sensor malfunction can be detected in the following thermistors:

1. Outdoor heat exchanger thermistor
2. Discharge pipe thermistor
3. Radiation fin thermistor
4. Outdoor temperature thermistor

3.12.2 Detection of Overcurrent and Overload

Outline

An excessive output current is detected and the OL temperature is observed to protect the compressor.

Detail

- If the OL (compressor head) temperature exceeds 120 ~130°C (depending on the model), the system shuts down the compressor.
- If the inverter current exceeds 14 ~ 18 A (depending on the model), the system shuts down the compressor. The upper limit of the current decreases when the outdoor temperature exceeds a certain level.

Part 5

Remote Controller

1. Remote Controller41

1. Remote Controller

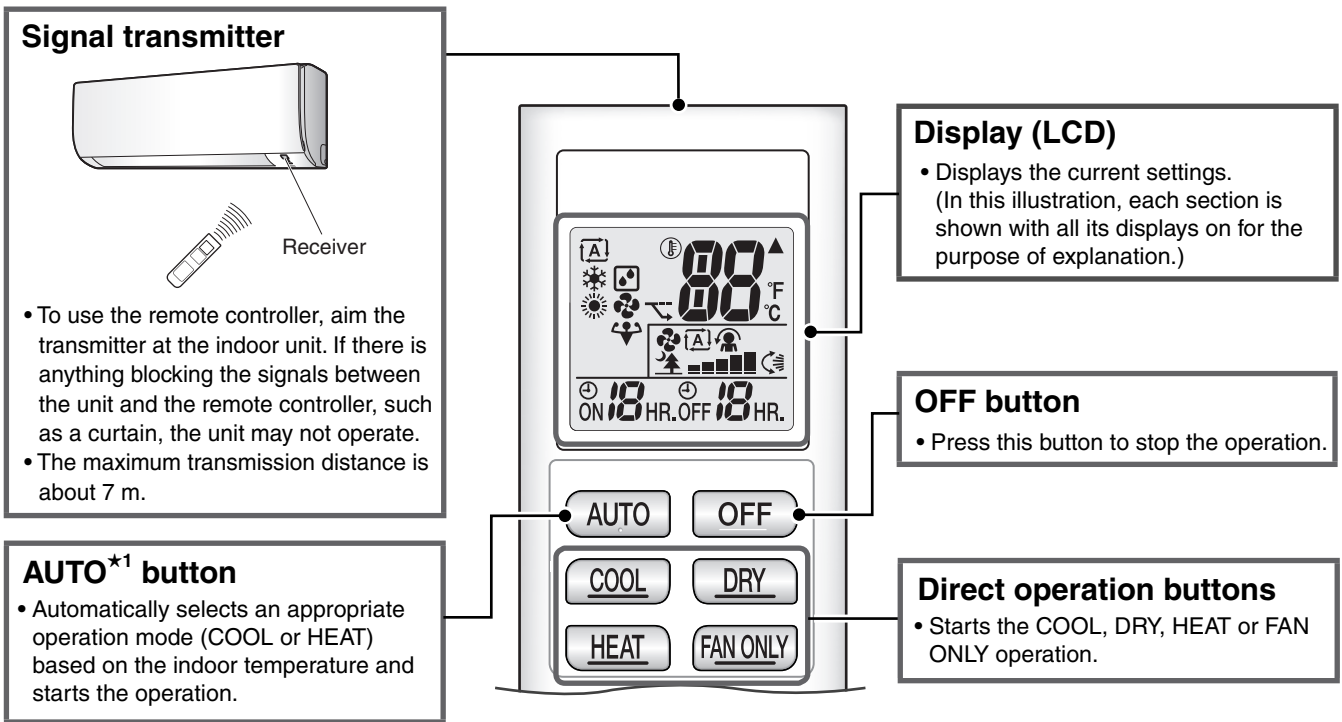

ARC480A11

(R22988)

Reference

Refer to the following pages for details.

★1	Automatic operation	P.20
----	---------------------	------



Note:

Refer to the operation manual of applicable model for details. You can download operation manuals from Daikin Business Portal:
 Daikin Business Portal → Document Search → Item Category → Installation/Operation Manual
 (URL: https://global1d.daikin.com/business_portal/login/)

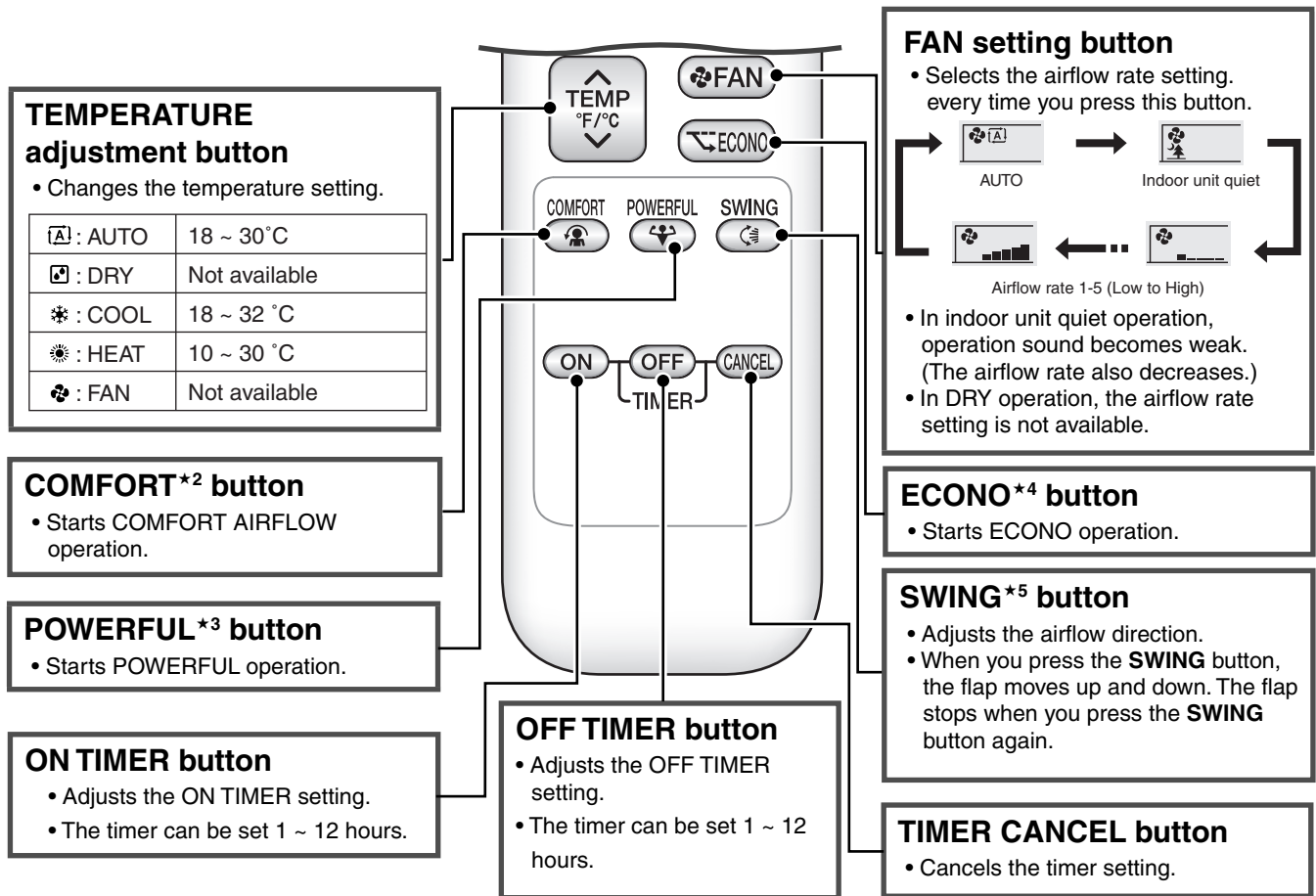

(R22989)

Reference

Refer to the following pages for details.

★2	COMFORT AIRFLOW operation	P.17 P.18	★4	ECONO operation	P.22
★3	Inverter POWERFUL operation	P.23	★5	Auto-swing	P.17



Note:

Refer to the operation manual of applicable model for details. You can download operation manuals from Daikin Business Portal:

Daikin Business Portal → Document Search → Item Category → Installation/Operation Manual
(URL: https://global1d.daikin.com/business_portal/login/)

Part 6

Service Diagnosis

1. General Problem Symptoms and Check Items	44
2. Troubleshooting with LED	45
2.1 Indoor Unit.....	45
2.2 Outdoor Unit.....	45
3. Service Diagnosis	46
4. Troubleshooting	49
4.1 Error Codes and Descriptions	49
4.2 Indoor Unit PCB Abnormality	50
4.3 Freeze-up Protection Control / Heating Peak-cut Control	51
4.4 Fan Motor (DC Motor) or Related Abnormality.....	52
4.5 Thermistor or Related Abnormality (Indoor Unit).....	54
4.6 Low-voltage Detection or Over-voltage Detection.....	55
4.7 Signal Transmission Error (Between Indoor Unit and Outdoor Unit).....	57
4.8 Unspecified Voltage (Between Indoor Unit and Outdoor Unit)	59
4.9 Outdoor Unit PCB Abnormality.....	60
4.10 OL Activation (Compressor Overload)	61
4.11 Compressor Lock	63
4.12 DC Fan Lock	64
4.13 Input Overcurrent Detection	65
4.14 Four Way Valve Abnormality.....	66
4.15 Discharge Pipe Temperature Control.....	68
4.16 High Pressure Control in Cooling	69
4.17 Compressor System Sensor Abnormality	70
4.18 Position Sensor Abnormality	71
4.19 Thermistor or Related Abnormality (Outdoor Unit).....	73
4.20 Electrical Box Temperature Rise.....	75
4.21 Radiation Fin Temperature Rise	76
4.22 Output Overcurrent Detection	77
5. Check.....	79
5.1 Thermistor Resistance Check	79
5.2 Indoor Fan Motor Connector Output Check	80
5.3 Power Supply Waveforms Check.....	81
5.4 Electronic Expansion Valve Check.....	81
5.5 Four Way Valve Performance Check	82
5.6 Inverter Unit Refrigerant System Check.....	82
5.7 Inverter Analyzer Check	83
5.8 Rotation Pulse Check on the Outdoor Unit PCB	85
5.9 Installation Condition Check.....	86
5.10 Discharge Pressure Check.....	86
5.11 Outdoor Fan System Check	87
5.12 Main Circuit Short Check.....	87
5.13 Power Module Check	88

1. General Problem Symptoms and Check Items

Symptom	Check Item	Measures	Reference Page
The unit does not operate.	Check the power supply.	Check if the rated voltage is supplied.	—
	Check the type of the indoor unit.	Check if the indoor unit type is compatible with the outdoor unit.	—
	Check the outdoor temperature.	Heating operation is not available when the outdoor temperature is 18°CWB or higher, and cooling operation is not available when the outdoor temperature is below -10°CDB.	—
	Diagnose with remote controller indication.	—	49
	Check the remote controller addresses.	Check if address settings for the remote controller and indoor unit are correct.	93
Operation sometimes stops.	Check the power supply.	A power failure of 2 to 10 cycles stops air conditioner operation. (Operation lamp OFF)	—
	Check the outdoor temperature.	Heating operation is not available when the outdoor temperature is 18°CWB or higher, and cooling operation is not available when the outdoor temperature is below -10°CDB.	—
	Diagnose with remote controller indication.	—	49
The unit operates but does not cool, or does not heat.	Check for wiring and piping errors in the connection between the indoor unit and outdoor unit.	—	—
	Check for thermistor detection errors.	Check if the thermistor is mounted securely.	—
	Check for faulty operation of the electronic expansion valve.	Set the unit to cooling operation, and check the temperature of the liquid pipe to see if the electronic expansion valve works.	—
	Diagnose with remote controller indication.	—	49
	Diagnose by service port pressure and operating current.	Check for refrigerant shortage.	—
Large operating noise and vibrations	Check the output voltage of the power module.	—	88
	Check the power module.	—	—
	Check the installation condition.	Check if the required spaces for installation (specified in the installation manual) are provided.	—

2. Troubleshooting with LED

2.1 Indoor Unit

Operation Lamp

The operation lamp blinks when any of the following errors is detected.

1. When a protection device of the indoor or outdoor unit is activated, or when the thermistor malfunctions.
 2. When a signal transmission error occurs between the indoor and outdoor units.
- In either case, conduct the diagnostic procedure described in the following pages.

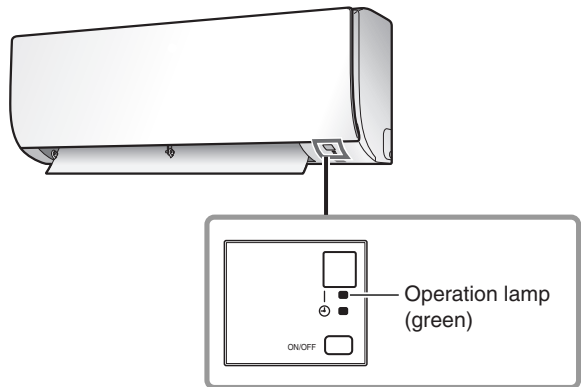

(R23077)

2.2 Outdoor Unit

The outdoor unit has a green LED (LED A) on the PCB. When the microcomputer works in order, the LED A blinks. However, the LED A turns OFF while the standby electricity saving function is activated and the power supply is OFF. (Refer to page 12, 13 for the location of LED A.)

3. Service Diagnosis

Method 1

1. When the **TIMER CANCEL** button is held down for 5 seconds, **00** is displayed on the temperature display screen.



(R21665)

2. Press the **TIMER CANCEL** button repeatedly until a long beep sounds.
 - The code indication changes in the sequence shown below.

No.	Code	No.	Code	No.	Code
1	00	16	83	31	UF
2	85	17	88	32	UH
3	E7	18	89	33	PY
4	F3	19	C9	34	H7
5	F6	20	CC	35	U2
6	L3	21	C4	36	ER
7	L4	22	C5	37	8H
8	L5	23	J3	38	FR
9	U4	24	J6	39	E8
10	E6	25	J8	40	C4
11	H6	26	E5	41	J9
12	H0	27	81	42	E3
13	86	28	E1	43	H3
14	U0	29	UR		
15	C7	30	U3		



Note:

1. A short beep and two consecutive beeps indicate non-corresponding codes.
2. To return to the normal mode, hold the **TIMER CANCEL** button down for 5 seconds. When the remote controller is left untouched for 60 seconds, it also returns to the normal mode.
3. Not all the error codes are displayed. When you cannot find the error code, try method 2. (→ Refer to page 47.)

Method 2

1. Press the center of the **TEMP** button and the **OFF** button at the same time.

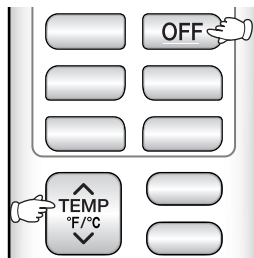

(R21666)

5ℓ is displayed on the LCD.

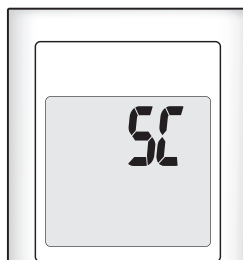

(R21059)

2. Select 5ℓ (service check) with the **TEMP** \wedge or **TEMP** \vee button.
3. Press the **FAN** button to enter the service check mode.

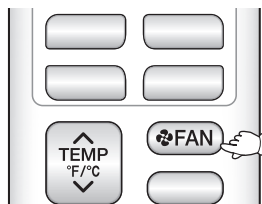

(R21667)

00 is displayed and the left-side number blinks.

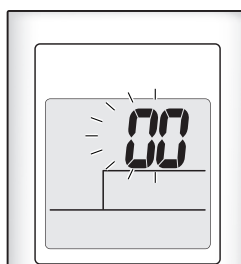

(R21061)

4. Press the **TEMP** \wedge or **TEMP** \vee button and change the number until you hear the two consecutive beeps or the long beep.

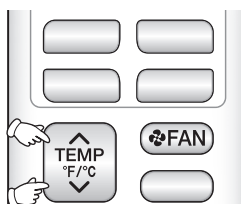

(R21668)

5. Diagnose by the sound.
 - ★ beep: The left-side number does not correspond with the error code.
 - ★ two consecutive beeps: The left-side number corresponds with the error code but the right-side number does not.
 - ★ long beep: Both the left-side and right-side numbers correspond with the error code.
(The numbers indicated when you hear the long beep are the error code.
→ Refer to page 49.)

6. Press the **FAN** button.

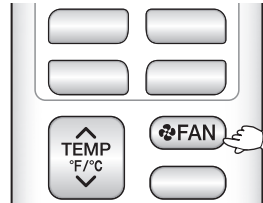

(R21667)

The right-side number blinks.

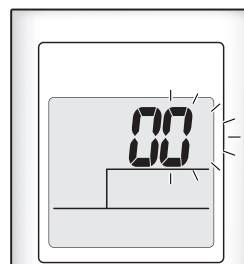

(R21063)

7. Press the **TEMP** \wedge or **TEMP** \vee button and change the number until you hear the long beep.

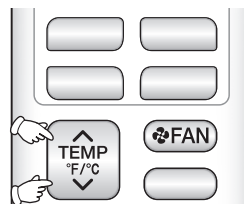

(R21668)

8. Diagnose by the sound.
 - ★ beep: The left-side number does not correspond with the error code.
 - ★ two consecutive beeps: The left-side number corresponds with the error code but the right-side number does not.
 - ★ long beep: Both the left-side and right-side numbers correspond with the error code.
9. Determine the error code.
The numbers indicated when you hear the long beep are the error code.
Error codes and description → Refer to page 49.

10. Press the **FAN** button for 5 seconds to exit from the service check mode.
(When the remote controller is left untouched for 60 seconds, it returns to the normal mode also.)

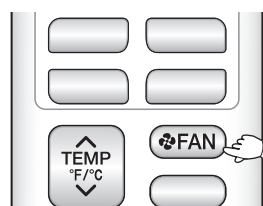

(R21667)

4. Troubleshooting

4.1 Error Codes and Descriptions

	Error Codes	Description	Reference Page
System	00	Normal	—
	U2	Low-voltage detection or over-voltage detection	55
	U4	Signal transmission error (between indoor unit and outdoor unit)	57
	UR	Unspecified voltage (between indoor unit and outdoor unit)	59
Indoor Unit	R1	Indoor unit PCB abnormality	50
	RS	Freeze-up protection control / heating peak-cut control	51
	RS	Fan motor (DC motor) or related abnormality	52
	C4	Indoor heat exchanger thermistor or related abnormality	54
	C9	Room temperature thermistor or related abnormality	54
Outdoor Unit	E1	Outdoor unit PCB abnormality	60
	E5★	OL activation (compressor overload)	61
	E6★	Compressor lock	63
	E7★	DC fan lock	64
	E8	Input overcurrent detection	65
	E9	Four way valve abnormality	66
	F3	Discharge pipe temperature control	68
	F6	High pressure control in cooling	69
	H0	Compressor system sensor abnormality	70
	H6	Position sensor abnormality	71
	H9	Outdoor temperature thermistor or related abnormality	73
	J3★	Discharge pipe thermistor or related abnormality	73
	J6	Outdoor heat exchanger thermistor or related abnormality	73
	L3	Electrical box temperature rise	75
	L4	Radiation fin temperature rise	76
	L5★	Output overcurrent detection	77
	P4	Radiation fin thermistor or related abnormality	73

★: Displayed only when system-down occurs.

4.2 Indoor Unit PCB Abnormality

Error Code	A1
Method of Error Detection	The system checks if the circuit works properly within the microcomputer of the indoor unit.
Error Decision Conditions	The system cannot set the internal settings.
Supposed Causes	<ul style="list-style-type: none"> ■ Wrong models interconnected ■ Defective indoor unit PCB ■ Disconnection of connector ■ Reduction of power supply voltage

Troubleshooting

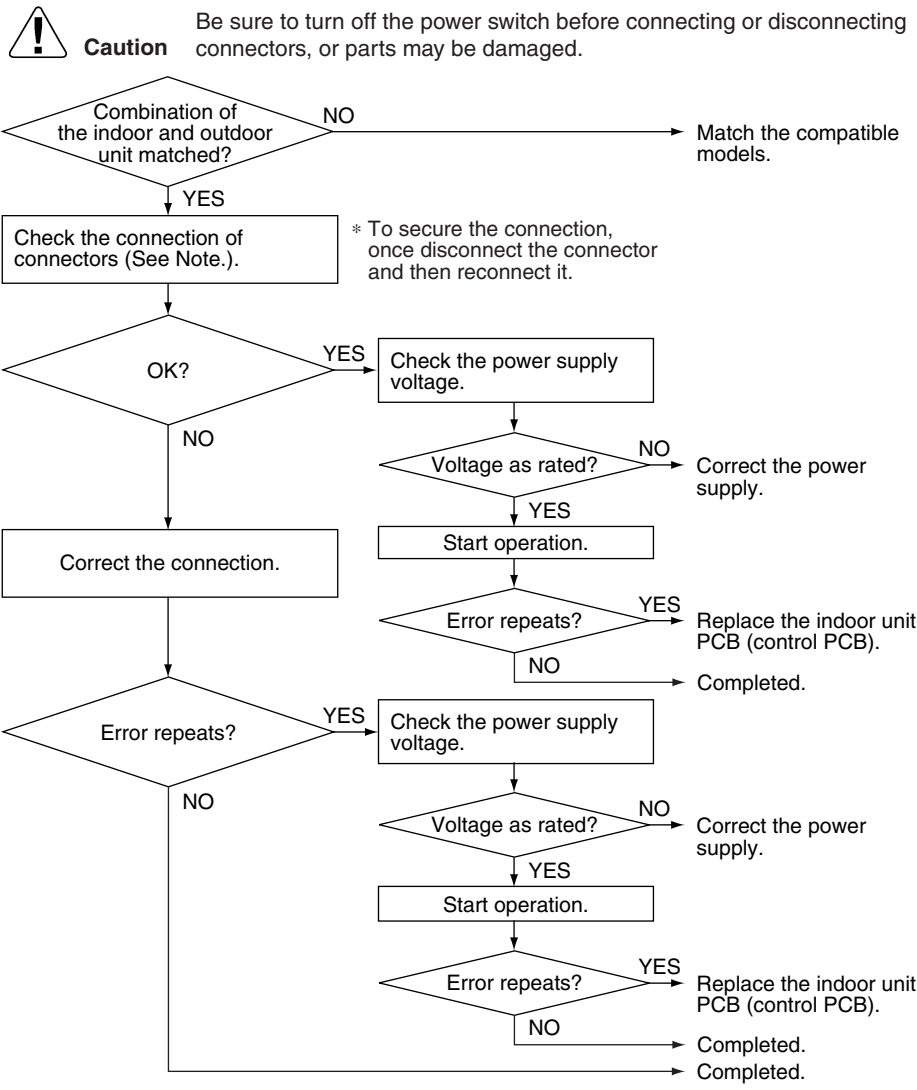

Note: Check the following connector.

Model Type	Connector
20/25/35 class	Terminal board ~ Control PCB (H1, H2, H3)
50/60/71 class	Terminal board ~ Filter PCB (S100)

(R20486)

4.3 Freeze-up Protection Control / Heating Peak-cut Control

Error Code	A5
Method of Error Detection	<ul style="list-style-type: none"> ■ Freeze-up protection control During cooling operation, the freeze-up protection control (operation halt) is activated according to the temperature detected by the indoor heat exchanger thermistor. ■ Heating peak-cut control During heating operation, the temperature detected by the indoor heat exchanger thermistor is used for the heating peak-cut control (operation halt, outdoor fan stop, etc.)
Error Decision Conditions	<ul style="list-style-type: none"> ■ Freeze-up protection control During cooling operation, the indoor heat exchanger temperature is below 0°C. ■ Heating peak-cut control During heating operation, the indoor heat exchanger temperature is above about 60°C.
Supposed Causes	<ul style="list-style-type: none"> ■ Short-circuited air ■ Clogged air filter of the indoor unit ■ Dust accumulation on the indoor heat exchanger ■ Defective indoor heat exchanger thermistor ■ Defective indoor unit PCB

Troubleshooting

Check No.01
 Refer to P.79

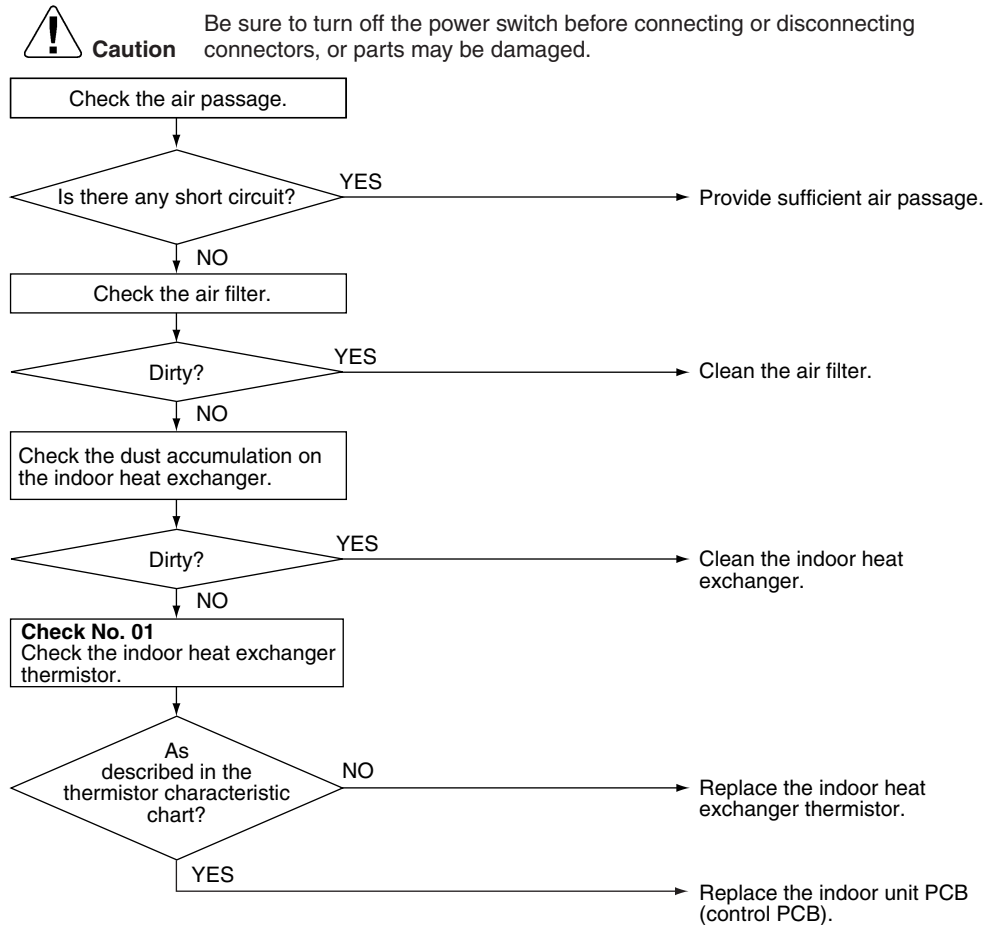

(R21064)

4.4 Fan Motor (DC Motor) or Related Abnormality

Error Code	FE
Method of Error Detection	The rotation speed detected by the Hall IC during fan motor operation is used to determine abnormal fan motor operation.
Error Decision Conditions	The detected rotation speed does not reach the demanded rotation speed of the target tap, and is less than 50% of the maximum fan motor rotation speed.
Supposed Causes	<ul style="list-style-type: none">■ Disconnection of connector■ Foreign matter stuck in the fan■ Layer short inside the fan motor winding■ Breaking of wire inside the fan motor■ Breaking of the fan motor lead wires■ Defective capacitor of the fan motor■ Defective indoor unit PCB

Troubleshooting



Check No.03
Refer to P.80



Caution Be sure to turn off the power switch before connecting or disconnecting connectors, or parts may be damaged.

Turn off the power supply.
(Unplug the power cable or turn the breaker off.)

Note: The motor may break when the motor connector is disconnected with the power supply on.
(Turn off the power supply before connecting the connector also.)

Check the connector for connection.

* To secure the connection, once disconnect the connector and then reconnect it.

OK?

NO → Correct the connection.

YES

Foreign matters in or around the fan?

YES → Remove the foreign matters.

NO

Rotate the fan by hand.

Fan rotates smoothly?

NO → Abnormal sound occurs?

Check No. 03
Check the fan motor for breakdown or short circuit.

Abnormal sound occurs?

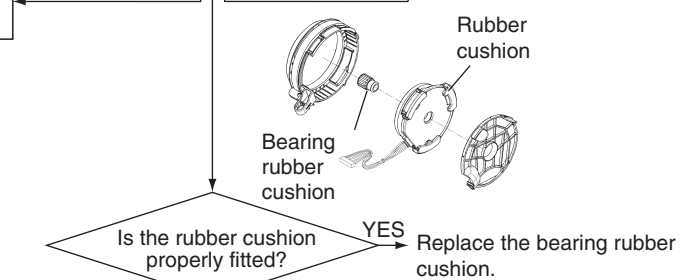

Is the rubber cushion properly fitted?

YES → Replace the bearing rubber cushion.
NO → Correct the position of rubber cushion or replace the rubber cushion.

Resistance OK?

NO → Replace the indoor fan motor.

YES

Turn the power on again.

Check No. 03
Check the motor control voltage.

Is the motor control voltage 15 VDC generated?

NO → Replace the indoor unit PCB (control PCB).

YES

Check No. 03
Check the indoor unit PCB for rotation pulse.

Is the rotation pulse generated?

NO → Replace the indoor fan motor.

YES

Replace the indoor unit PCB (control PCB). (R20165)

4.5 Thermistor or Related Abnormality (Indoor Unit)

Error Code **U4, U9**

Method of Error Detection The temperatures detected by the thermistors determine thermistor errors.

Error Decision Conditions The voltage between the both ends of the thermistor is 4.96 V and more or 0.04 V and less during compressor operation.

Supposed Causes

- Disconnection of connector
- Thermistor corresponding to the error code is defective.
- Defective indoor unit PCB

Troubleshooting

Check No.01
 Refer to P.79



Caution

Be sure to turn off the power switch before connecting or disconnecting connectors, or parts may be damaged.

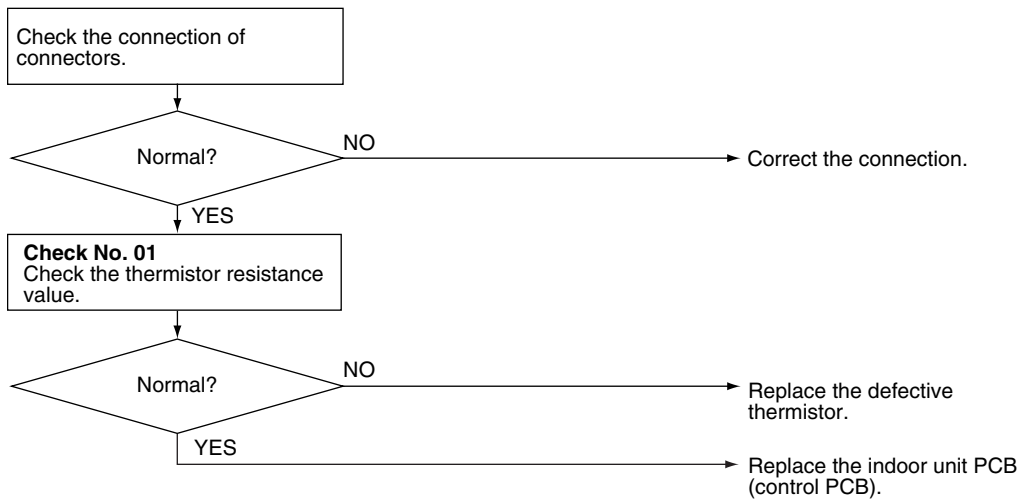

(R21870)

U4 : Indoor heat exchanger thermistor

U9 : Room temperature thermistor

4.6 Low-voltage Detection or Over-voltage Detection

Error Code	U2
Method of Error Detection	<p>Low-voltage detection: An abnormal voltage drop is detected by the DC voltage detection circuit.</p> <p>Over-voltage detection: An abnormal voltage rise is detected by the over-voltage detection circuit.</p>
Error Decision Conditions	<p>Low-voltage detection:</p> <ul style="list-style-type: none"> ■ The voltage detected by the DC voltage detection circuit is below 180 ~ 196 V (depending on the model). ■ The compressor stops if the error occurs, and restarts automatically after 3-minute standby. <p>Over-voltage detection:</p> <ul style="list-style-type: none"> ■ An over-voltage signal is fed from the over-voltage detection circuit to the microcomputer (over 458 ~ 500 V, depending on the model). ■ The compressor stops if the error occurs, and restarts automatically after 3-minute standby.
Supposed Causes	<ul style="list-style-type: none"> ■ Power supply voltage is not as specified. ■ Defective DC voltage detection circuit ■ Defective over-voltage detection circuit ■ Defective PAM control part ■ Disconnection of compressor harness ■ Short circuit inside the fan motor winding ■ Noise ■ Momentary drop of voltage ■ Momentary power failure ■ Defective outdoor unit PCB

Troubleshooting

**Caution**

Be sure to turn off the power switch before connecting or disconnecting connectors, or parts may be damaged.

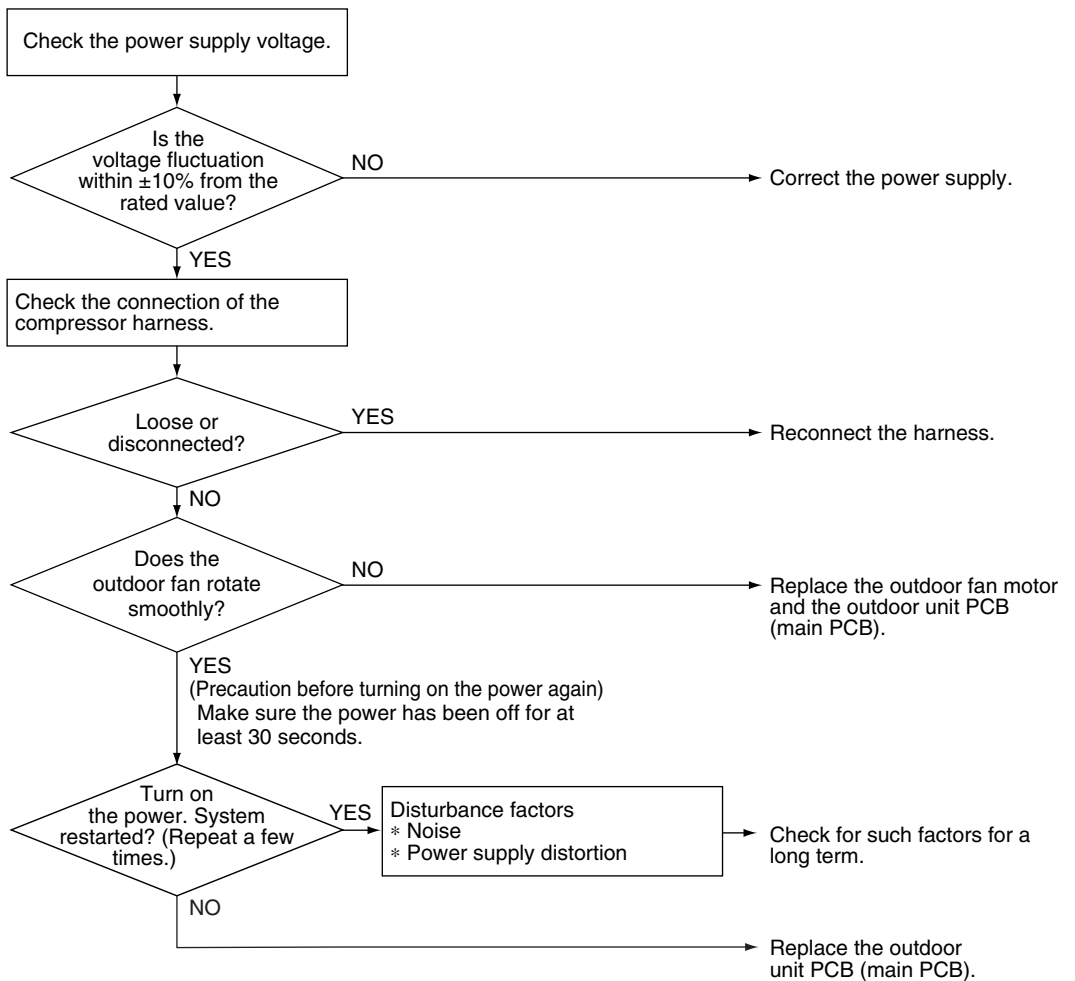

(R22990)

4.7 Signal Transmission Error (Between Indoor Unit and Outdoor Unit)

Error Code	U4
Method of Error Detection	The data received from the outdoor unit in signal transmission is checked whether it is normal.
Error Decision Conditions	The data sent from the outdoor unit cannot be received normally, or the content of the data is abnormal.
Supposed Causes	<ul style="list-style-type: none">■ Power supply voltage is not as specified.■ Reduction of power supply voltage■ Wiring error■ Breaking of the connecting wires between the indoor and outdoor units (wire No. 3)■ Defective outdoor unit PCB■ Short circuit inside the fan motor winding■ Defective indoor unit PCB■ Disturbed power supply waveform

Troubleshooting



Check No.11
Refer to P.81



Caution Be sure to turn off the power switch before connecting or disconnecting connectors, or parts may be damaged.

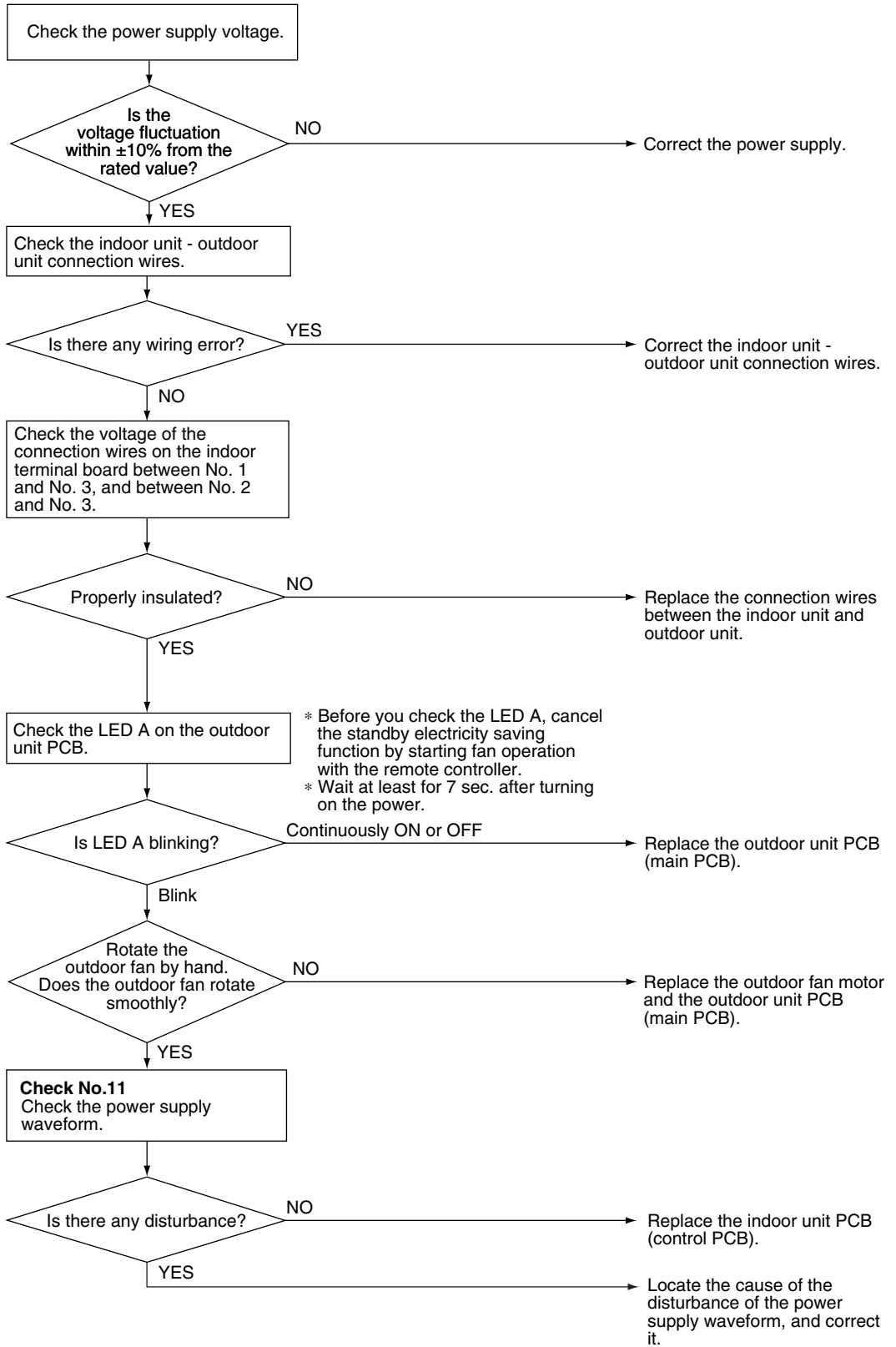

(R22043)

4.8 Unspecified Voltage (Between Indoor Unit and Outdoor Unit)

Error Code	U9
Method of Error Detection	The supply power is detected for its requirements (pair type is different from multi type) by the indoor / outdoor transmission signal.
Error Decision Conditions	The pair type and multi type are interconnected.
Supposed Causes	<ul style="list-style-type: none"> ■ Wrong models interconnected ■ Wrong wiring of connecting wires ■ Wrong indoor unit PCB or outdoor unit PCB mounted ■ Defective indoor unit PCB ■ Defective outdoor unit PCB

Troubleshooting

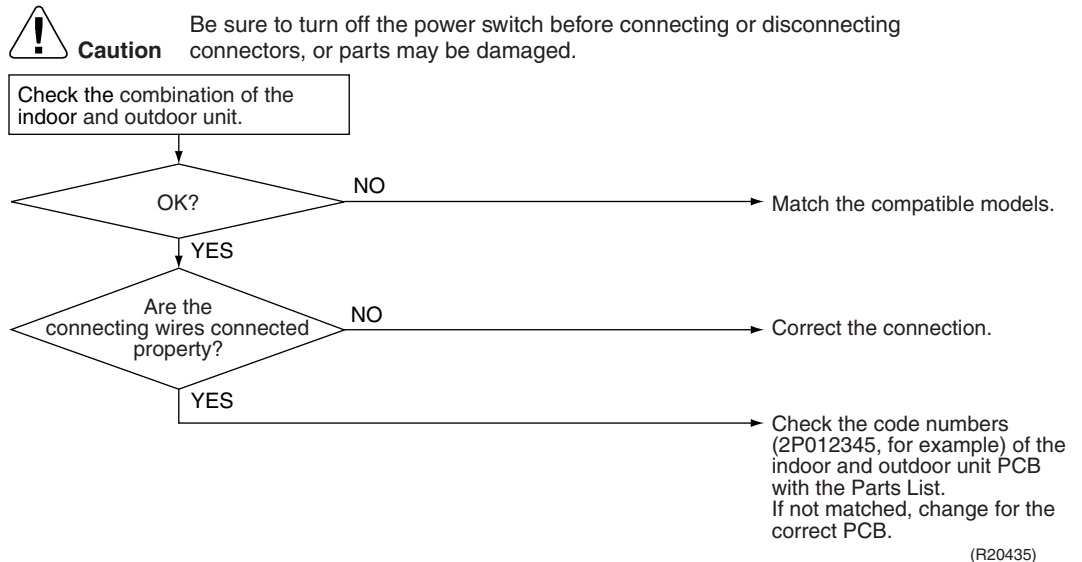

4.9 Outdoor Unit PCB Abnormality

Error Code	E1
Method of Error Detection	<ul style="list-style-type: none"> ■ The system checks if the microprocessor is working in order. ■ The system checks if the zero-cross signal comes in properly.
Error Decision Conditions	<ul style="list-style-type: none"> ■ The microprocessor program runs out of control. ■ The zero-cross signal is not detected.
Supposed Causes	<ul style="list-style-type: none"> ■ Defective outdoor unit PCB ■ Noise ■ Momentary drop of voltage ■ Momentary power failure

Troubleshooting

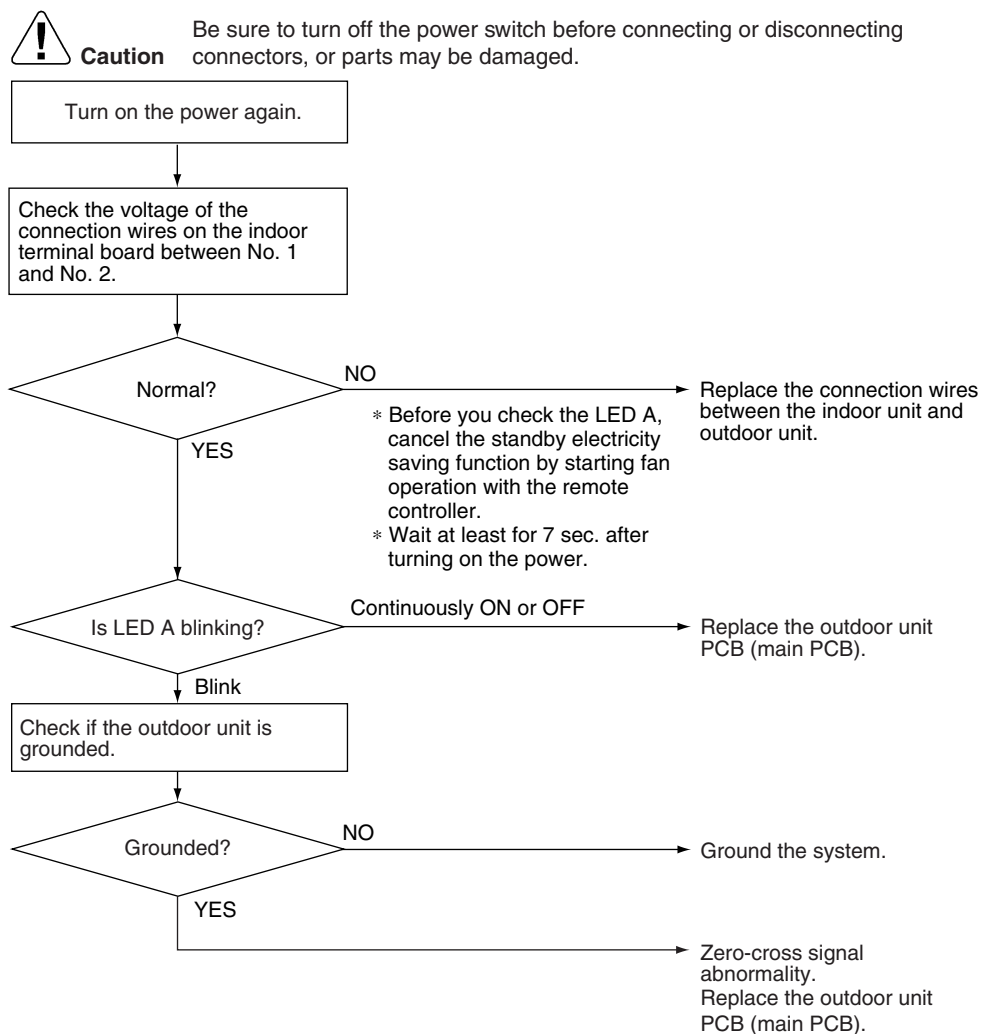

4.10 OL Activation (Compressor Overload)

Error Code	E5
Method of Error Detection	A compressor overload is detected through compressor OL.
Error Decision Conditions	<ul style="list-style-type: none">■ If the error repeats, the system is shut down.■ Reset condition: Continuous run for about 60 minutes without any other error
Supposed Causes	<ul style="list-style-type: none">■ Disconnection of discharge pipe thermistor■ Defective discharge pipe thermistor■ Disconnection of connector S40■ Disconnection of 2 terminals of OL (Q1L)■ Defective OL (Q1L)■ Broken OL harness■ Defective electronic expansion valve or coil■ Defective four way valve or coil■ Defective outdoor unit PCB■ Refrigerant shortage■ Water mixed in refrigerant■ Defective stop valve

Troubleshooting



Check No.01
 Refer to P.79

Check No.12
 Refer to P.81

Check No.13
 Refer to P.82

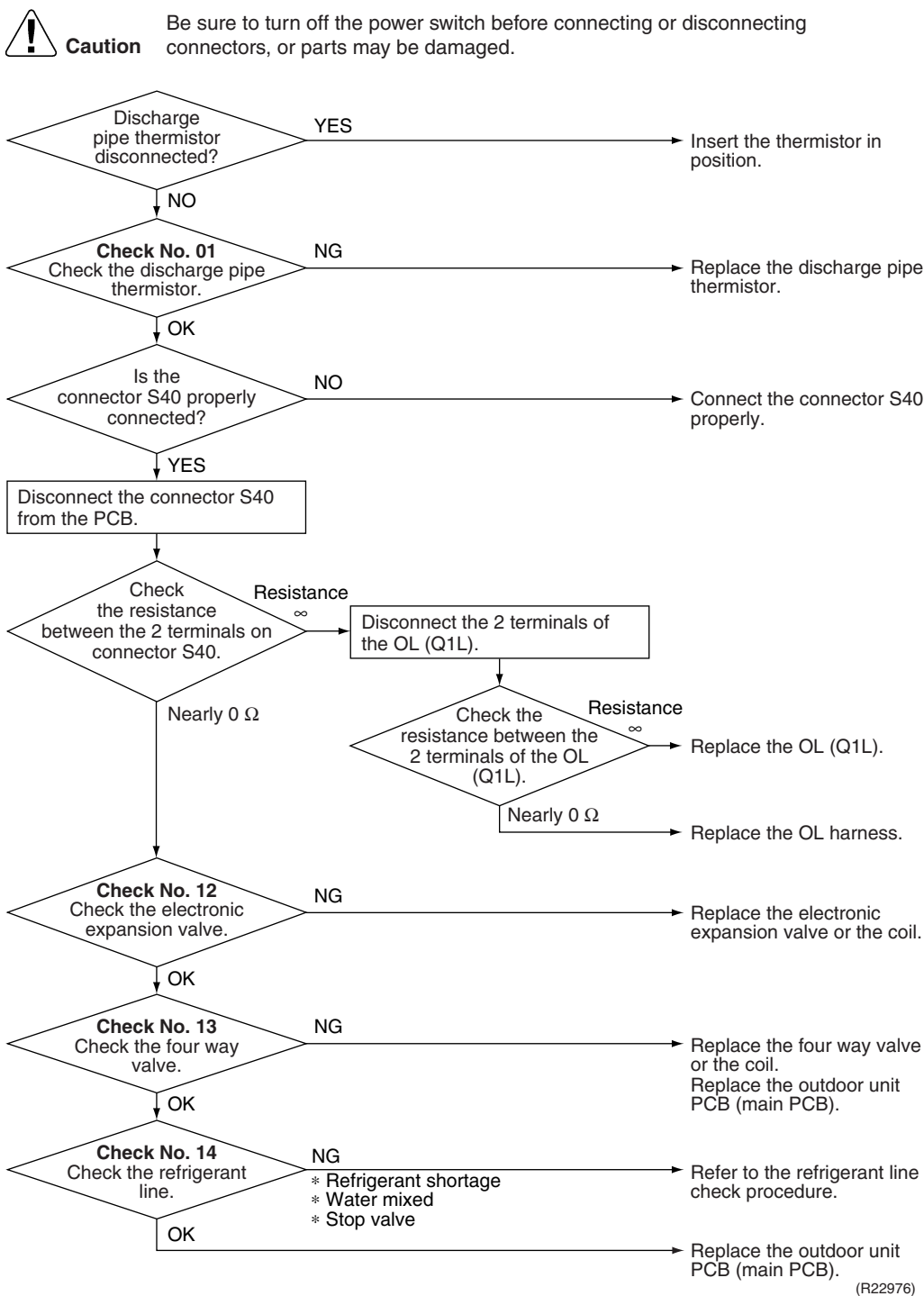
Check No.14
 Refer to P.82



 **Note:** OL (Q1L) activating temperature: 120~130°C
 OL (Q1L) recovery temperature: 95°C

(R22976)

4.11 Compressor Lock

Error Code	EE
Method of Error Detection	A compressor lock is detected by the current waveform generated when applying high-frequency voltage to the motor.
Error Decision Conditions	<ul style="list-style-type: none"> ■ If the error repeats, the system is shut down. ■ Reset condition: Continuous run for about 11 minutes without any other error
Supposed Causes	<ul style="list-style-type: none"> ■ Closed stop valve ■ Compressor locked ■ Disconnection of compressor harness

Troubleshooting

 **Check No.12**
Refer to P.81

 **Check No.15**
Refer to P.83

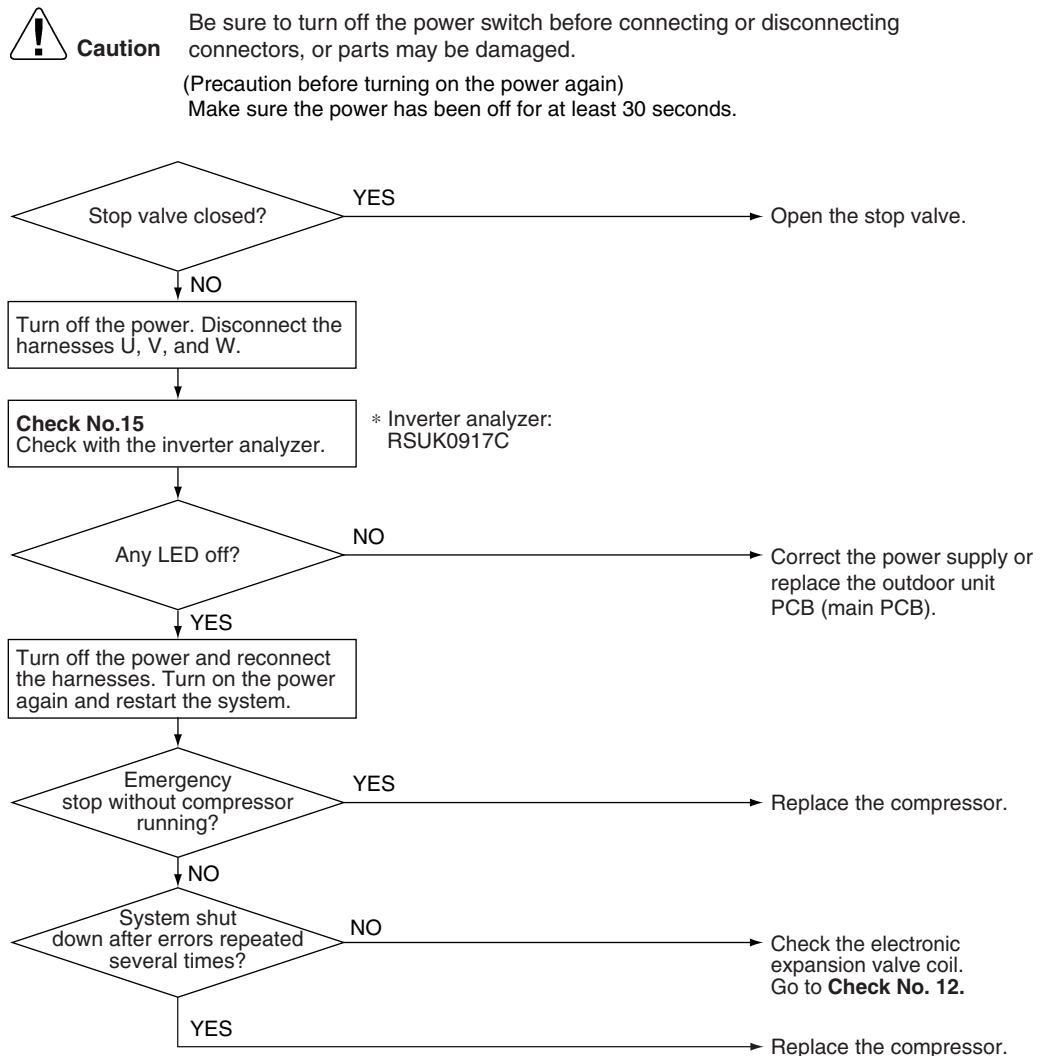

(R21067)

4.12 DC Fan Lock

Error Code

E7

Method of Error Detection

An error is determined with the high-voltage fan motor rotation speed detected by the Hall IC.

Error Decision Conditions

- The fan does not start in 15 ~ 30 seconds (depending on the model) even when the fan motor is running.
- If the error repeats, the system is shut down.
- Reset condition: Continuous run for about 11 minutes without any other error

Supposed Causes

- Disconnection of the fan motor
- Foreign matter stuck in the fan
- Defective fan motor
- Defective outdoor unit PCB

Troubleshooting



Check No.16
Refer to P.85

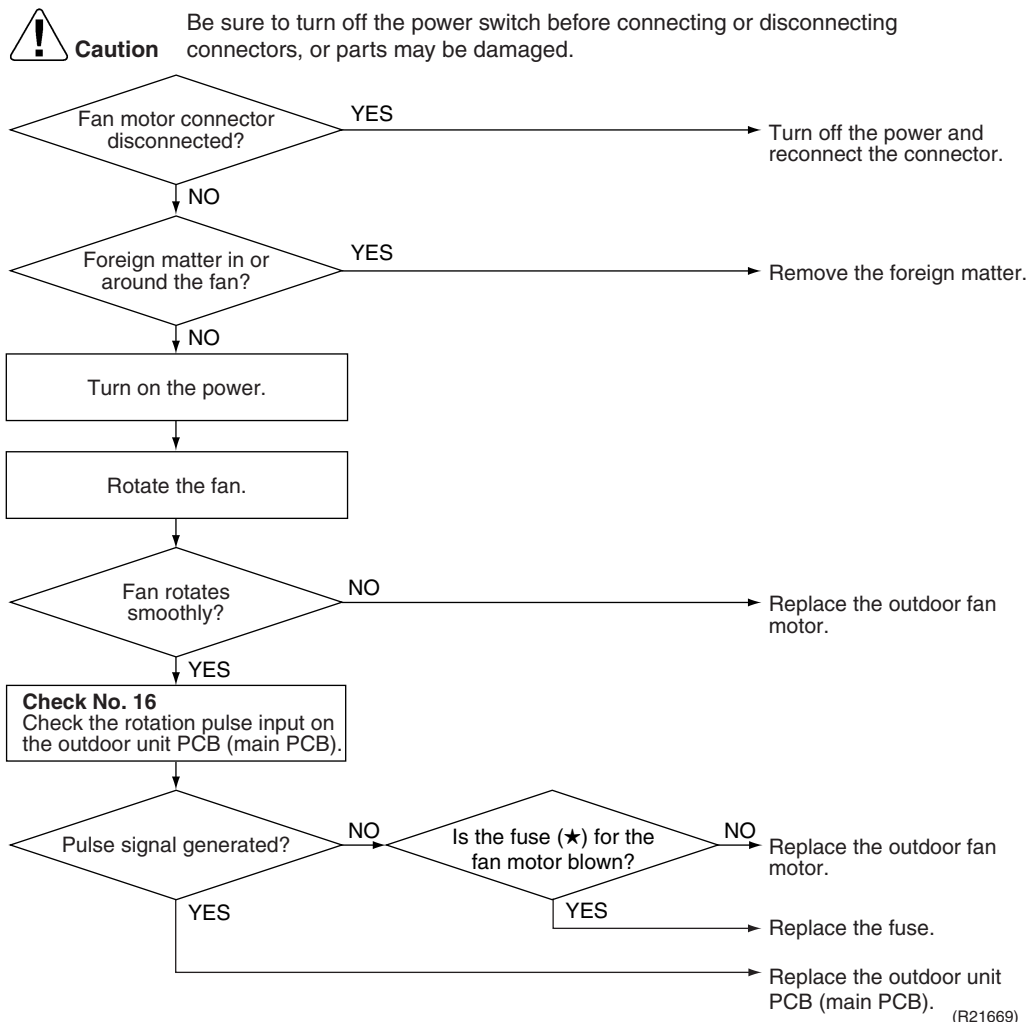

★ FU2

4.13 Input Overcurrent Detection

Error Code	E8
Method of Error Detection	An input overcurrent is detected by checking the input current value with the compressor running.
Error Decision Conditions	The current exceeds about 14 ~ 18 A (depending on the model and operation mode) for 2.5 seconds with the compressor running. (The upper limit of the current decreases when the outdoor temperature exceeds a certain level.)
Supposed Causes	<ul style="list-style-type: none"> ■ Outdoor temperature is out of operation range. ■ Defective compressor ■ Defective power module ■ Defective outdoor unit PCB ■ Short circuit

Troubleshooting

Check No.15
 Refer to P.83

Check No.17
 Refer to P.86

Check No.18
 Refer to P.86

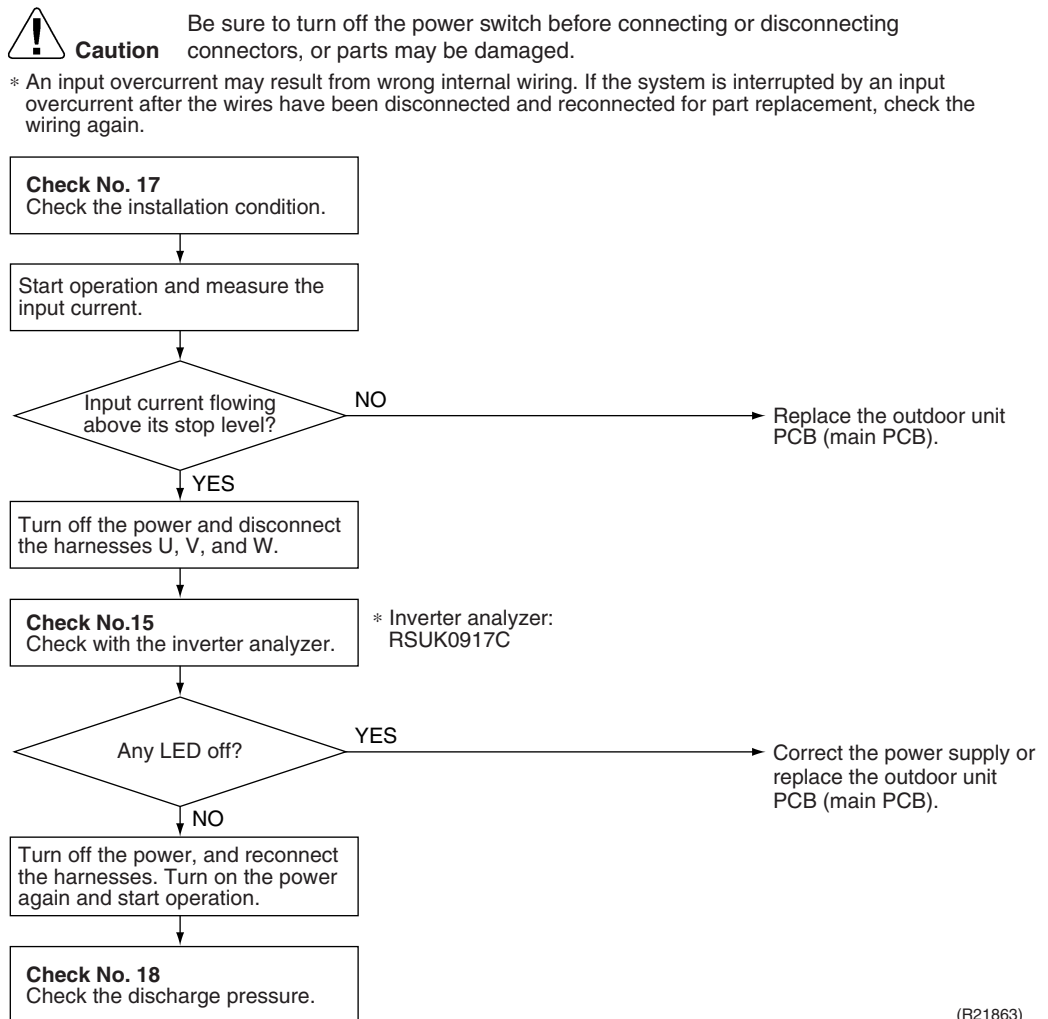

(R21863)

4.14 Four Way Valve Abnormality

Error Code	E8
Method of Error Detection	The room temperature thermistor and the indoor heat exchanger thermistor are checked if they function within their normal ranges in each operation mode.
Error Decision Conditions	<p>A following condition continues over 10 minute after operating for 5 minutes.</p> <p>Cooling / Dry $A - B < -5^{\circ}\text{C}$</p> <p>Heating $B - A < -5^{\circ}\text{C}$</p> <p>A: Room thermistor temperature B: Indoor heat exchanger temperature</p> <ul style="list-style-type: none"> ■ If the error repeats, the system is shut down. ■ Reset condition: Continuous run for about 60 minutes without any other error
Supposed Causes	<ul style="list-style-type: none"> ■ Disconnection of four way valve coil ■ Defective four way valve, coil, or harness ■ Defective outdoor unit PCB ■ Defective thermistor ■ Refrigerant shortage ■ Water mixed in refrigerant ■ Defective stop valve

Troubleshooting

Check No.01
 Refer to P.79

Check No.13
 Refer to P.82

Check No.14
 Refer to P.82

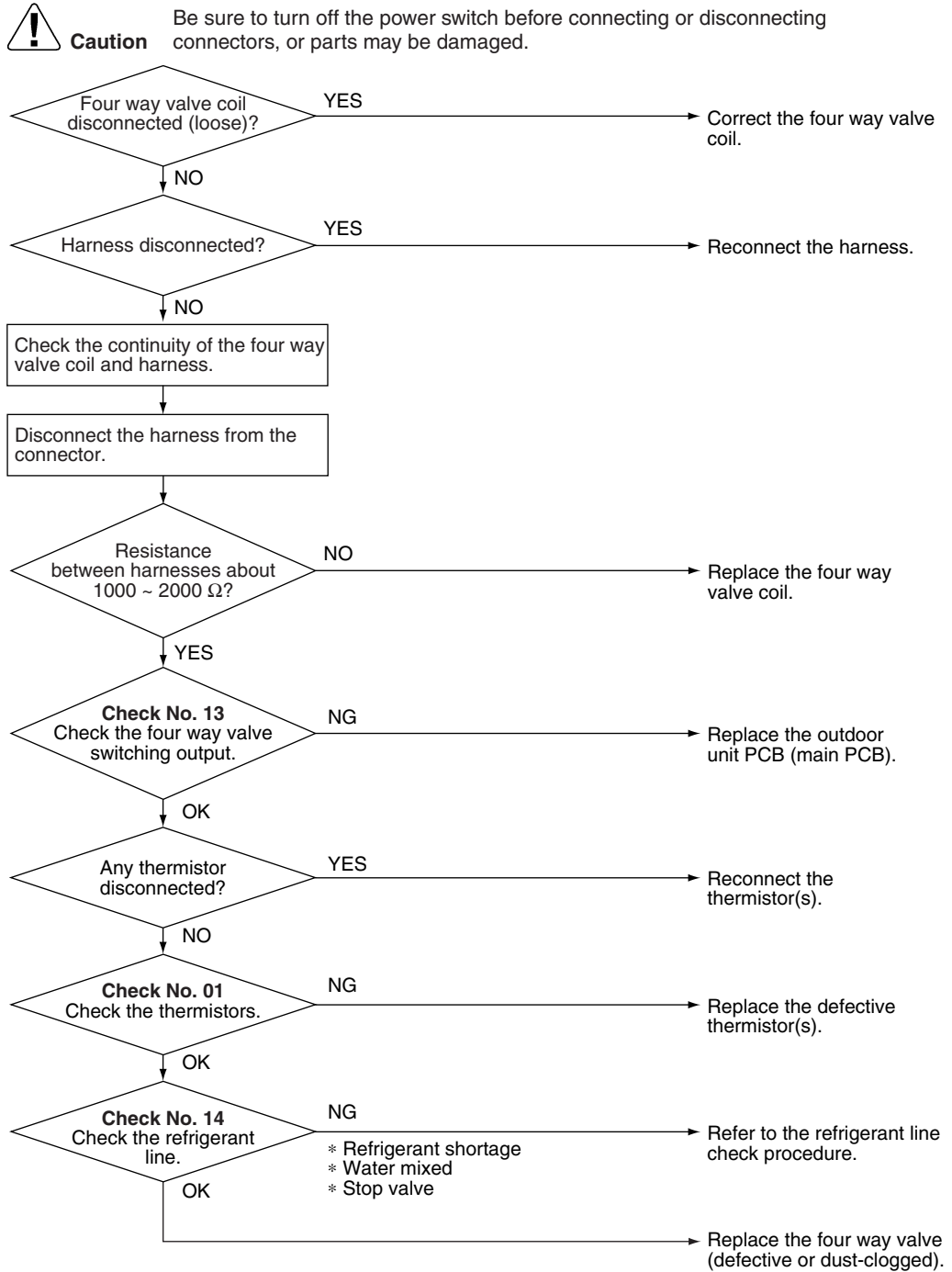

(R20405)

4.15 Discharge Pipe Temperature Control

Error Code

E3

Method of Error Detection

An error is determined with the temperature detected by the discharge pipe thermistor.

Error Decision Conditions

- If the temperature detected by the discharge pipe thermistor rises above **A**°C, the compressor stops.
- The error is cleared when the discharge pipe temperature has dropped below **B**°C.

	A (°C)	B (°C)
20/25/35 class	110	88
50/60/71 class	110	95

- If the error repeats, the system is shut down.
- Reset condition: Continuous run for about 60 minutes without any other error

Supposed Causes

- Defective discharge pipe thermistor
(Defective outdoor heat exchanger thermistor or outdoor temperature thermistor)
- Defective electronic expansion valve or coil
- Refrigerant shortage
- Defective four way valve
- Water mixed in refrigerant
- Defective stop valve
- Defective outdoor unit PCB

Troubleshooting

Check No.01
 Refer to P.79

Check No.12
 Refer to P.81



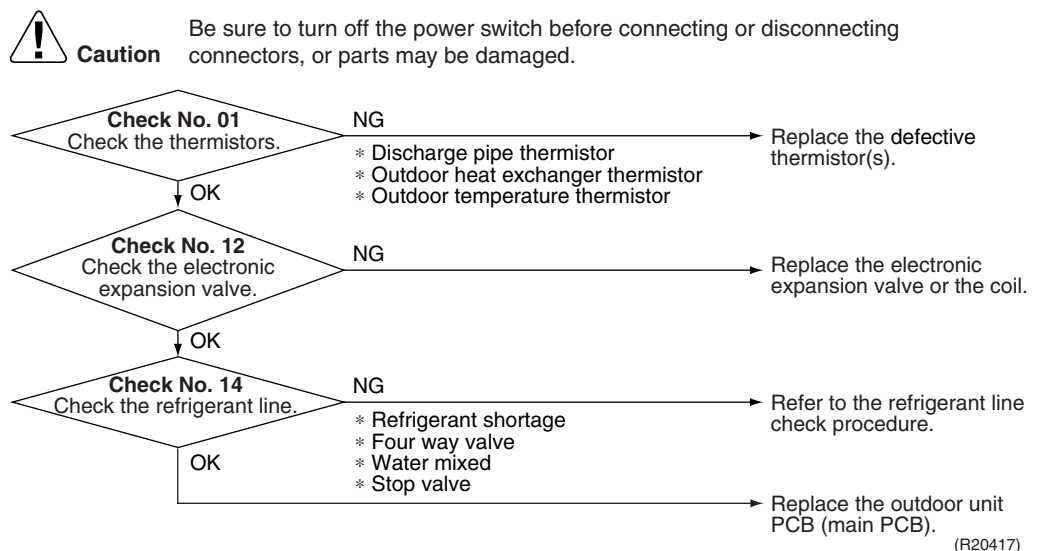



Check No.14
 Refer to P.82



4.16 High Pressure Control in Cooling

Error Code	F6
Method of Error Detection	High-pressure control (operation halt, frequency drop, etc.) is activated in cooling operation if the temperature sensed by the outdoor heat exchanger thermistor exceeds the limit.
Error Decision Conditions	<ul style="list-style-type: none"> ■ The temperature sensed by the outdoor heat exchanger thermistor rise above 61°C (depending on the model). ■ The error is cleared when the temperature drops below 51 ~ 52°C (depending on the model).
Supposed Causes	<ul style="list-style-type: none"> ■ The installation space is not large enough. ■ Dirty outdoor heat exchanger ■ Defective outdoor fan motor ■ Defective stop valve ■ Defective electronic expansion valve or coil ■ Defective outdoor heat exchanger thermistor ■ Defective outdoor unit PCB

Troubleshooting

-  **Check No.01**
Refer to P.79
-  **Check No.12**
Refer to P.81
-  **Check No.17**
Refer to P.86
-  **Check No.18**
Refer to P.86
-  **Check No.19**
Refer to P.87

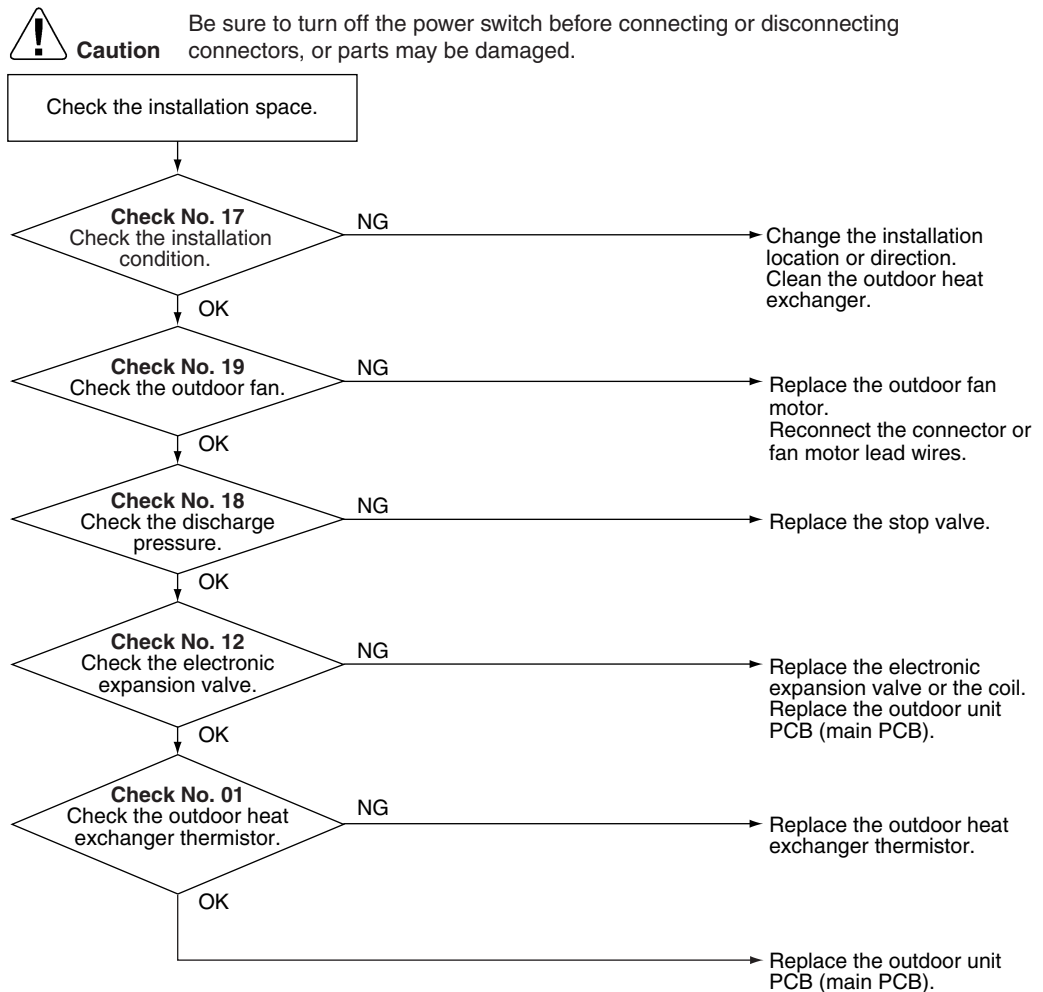

(R20418)

4.17 Compressor System Sensor Abnormality

Error Code	H0
Method of Error Detection	The system checks the DC current before the compressor starts.
Error Decision Conditions	<ul style="list-style-type: none"> ■ The voltage converted from the DC current before compressor start-up is out of the range 0.5 ~ 4.5 V. ■ The DC voltage before compressor start-up is below 50 V.
Supposed Causes	<ul style="list-style-type: none"> ■ Broken or disconnected harness ■ Defective outdoor unit PCB
Troubleshooting	

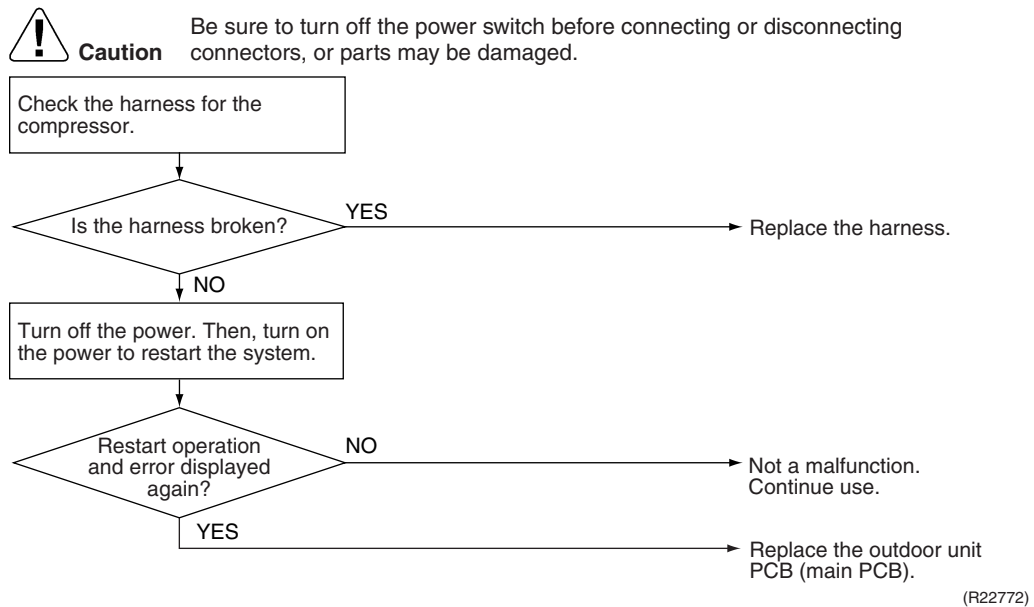

4.18 Position Sensor Abnormality

Error Code	H6
Method of Error Detection	A compressor start-up failure is detected by checking the compressor running condition through the position detection circuit.
Error Decision Conditions	<ul style="list-style-type: none">■ If the error repeats, the system is shut down.■ Reset condition: Continuous run for about 11 minutes without any other error
Supposed Causes	<ul style="list-style-type: none">■ Power supply voltage is not as specified.■ Disconnection of the compressor harness■ Defective compressor■ Defective outdoor unit PCB■ Start-up failure caused by the closed stop valve■ Input voltage is outside the specified range.

Troubleshooting

Check No.15
 Refer to P.83

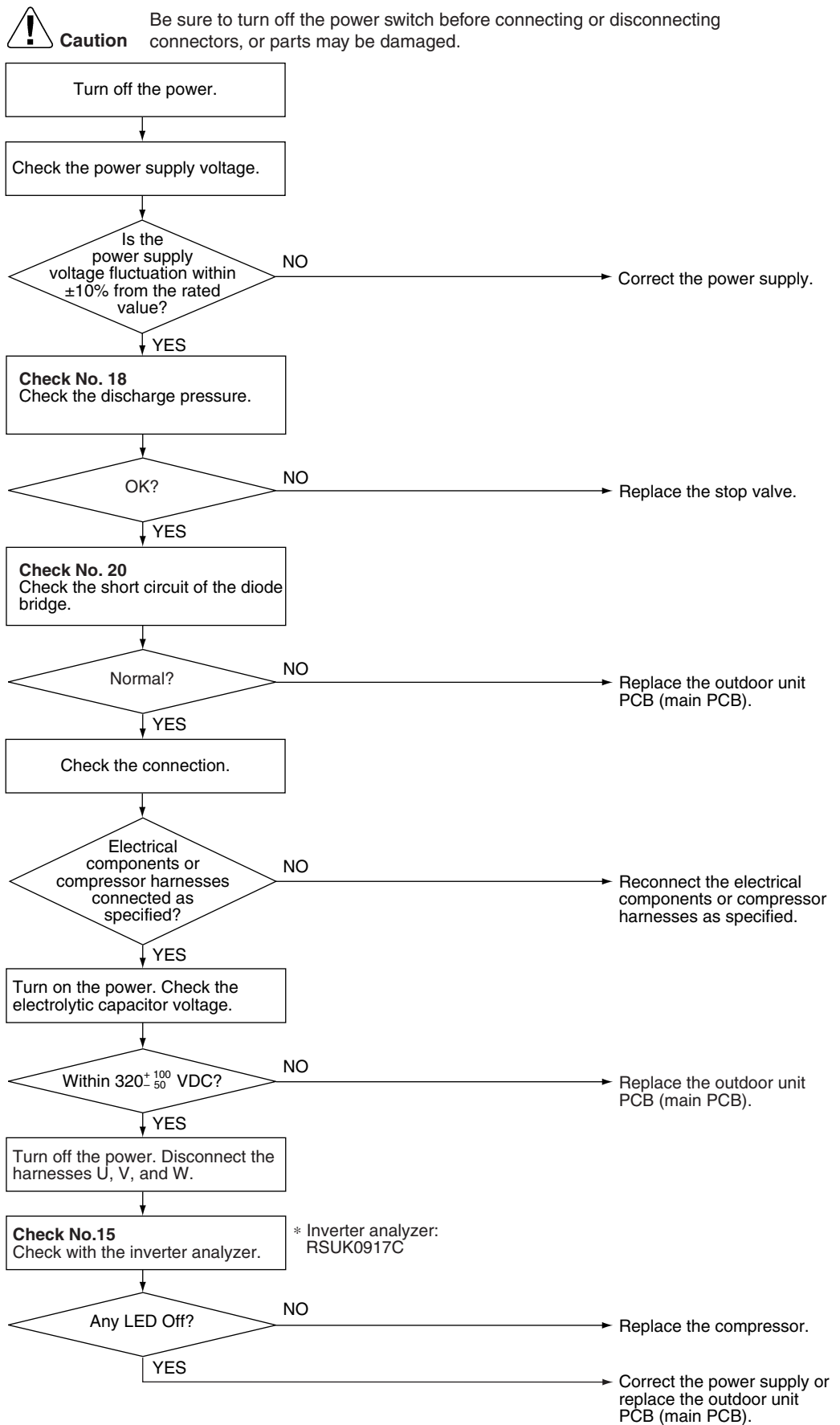

Check No.18
 Refer to P.86

Check No.20
 Refer to P.87



(R22764)

4.19 Thermistor or Related Abnormality (Outdoor Unit)

Error Code	<i>H9, U3, UE, P4</i>
Method of Error Detection	This fault is identified based on the thermistor input voltage to the microcomputer. A thermistor fault is identified based on the temperature sensed by each thermistor.
Error Decision Conditions	<ul style="list-style-type: none"> ■ The voltage between the both ends of the thermistor is above 4.96 V or below 0.04 V with the power on. ■ <i>U3</i> error is judged if the discharge pipe temperature is lower than the heat exchanger temperature.
Supposed Causes	<ul style="list-style-type: none"> ■ Disconnection of the connector for the thermistor ■ Thermistor corresponding to the error code is defective. ■ Defective heat exchanger thermistor in the case of <i>U3</i> error (outdoor heat exchanger thermistor in cooling operation, or indoor heat exchanger thermistor in heating operation) ■ Defective outdoor unit PCB
Troubleshooting	<p>In case of <i>P4</i></p> <p> Caution Be sure to turn off the power switch before connecting or disconnecting connectors, or parts may be damaged.</p> <p>Replace the outdoor unit PCB (main PCB).</p> <p><i>P4</i> : Radiation fin thermistor</p>

Troubleshooting

Check No.01
 Refer to P.79

In case of *H3*, *J3*, *J5*

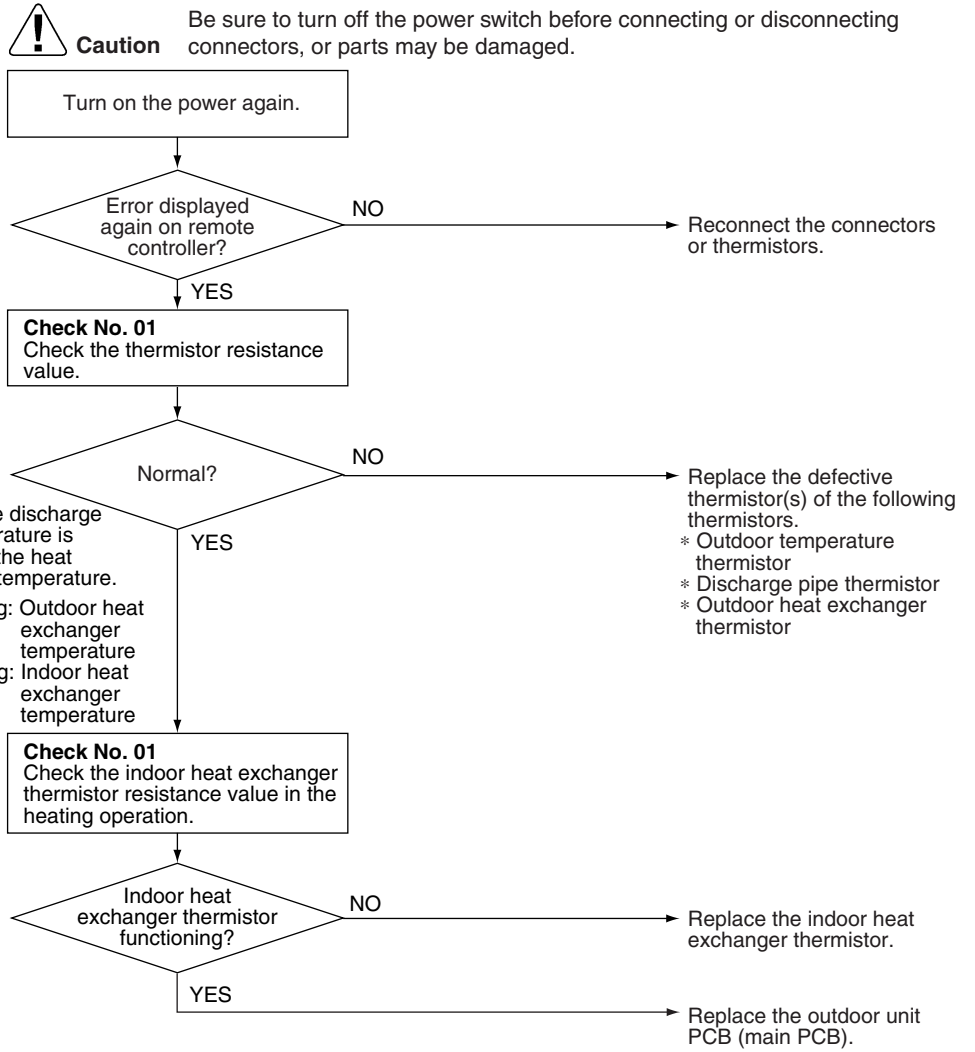

(R20406)

- H3* : Outdoor temperature thermistor
- J3* : Discharge pipe thermistor
- J5* : Outdoor heat exchanger thermistor

4.20 Electrical Box Temperature Rise

Error Code	L3		
Method of Error Detection	An electrical box temperature rise is detected by checking the radiation fin thermistor with the compressor off.		
Error Decision Conditions	<ul style="list-style-type: none"> ■ With the compressor off, the radiation fin temperature is above A°C. ■ The error is cleared when the radiation fin temperature drops below B°C. ■ To cool the electrical components, the outdoor fan starts when the radiation fin temperature rises above C°C and stops when the radiation fin temperature drops below B°C. 		
	A (°C)	B (°C)	C (°C)
20/25/35 class	93	70	78
50/60/71 class	90	64	81
Supposed Causes	<ul style="list-style-type: none"> ■ Defective outdoor fan motor ■ Short circuit ■ Defective radiation fin thermistor ■ Disconnection of connector ■ Defective outdoor unit PCB 		

Troubleshooting

 **Check No.17**
Refer to P.86

 **Check No.19**
Refer to P.87

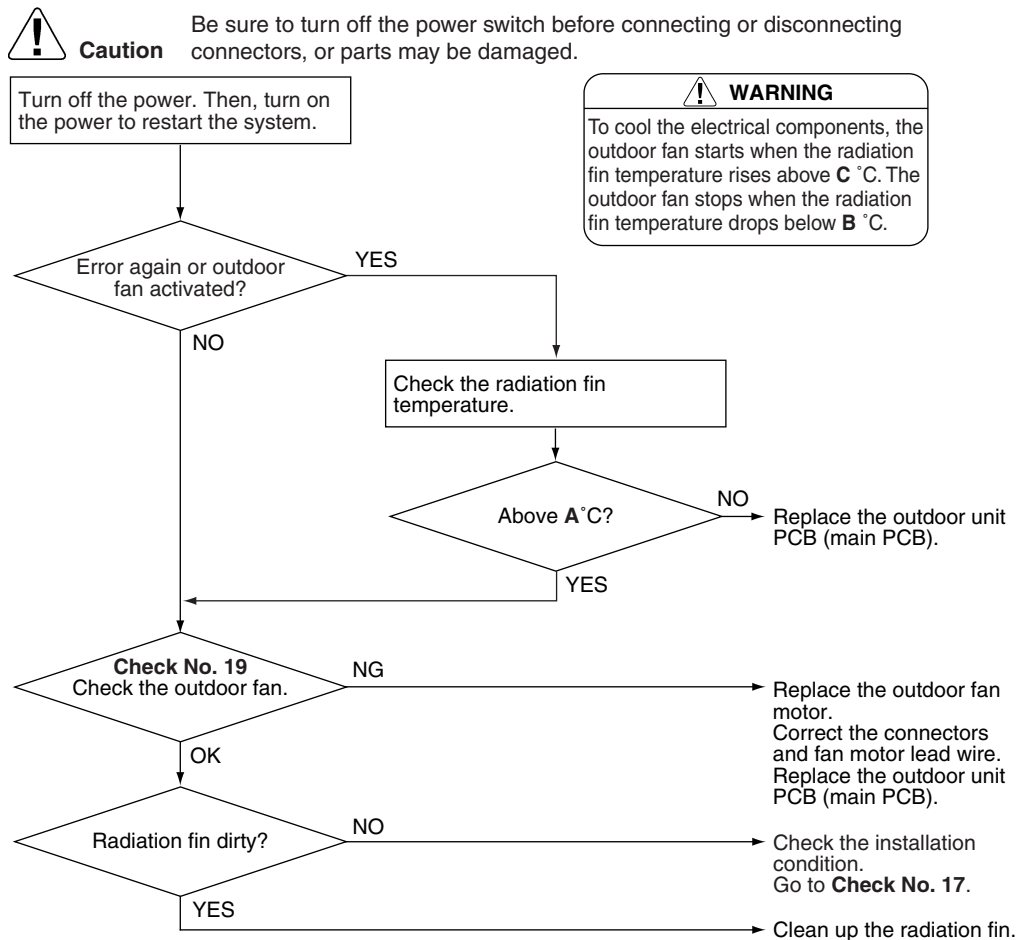

(R21436)

4.21 Radiation Fin Temperature Rise

Error Code L4

Method of Error Detection A radiation fin temperature rise is detected by checking the radiation fin thermistor with the compressor on.

- Error Decision Conditions**
- If the radiation fin temperature with the compressor on is above **A**°C.
 - The error is cleared when the radiation fin temperature drops below **B**°C.
 - If the error repeats, the system is shut down.
 - Reset condition: Continuous run for about 60 minutes without any other error

	A (°C)	B (°C)
20/25/35 class	93	78
50/60/71 class	100	57

- Supposed Causes**
- Defective outdoor fan motor
 - Short circuit
 - Defective radiation fin thermistor
 - Disconnection of connector
 - Defective outdoor unit PCB
 - Silicone grease is not applied properly on the radiation fin after replacing the outdoor unit PCB.

Troubleshooting

Check No.17
Refer to P.86

Check No.19
Refer to P.87

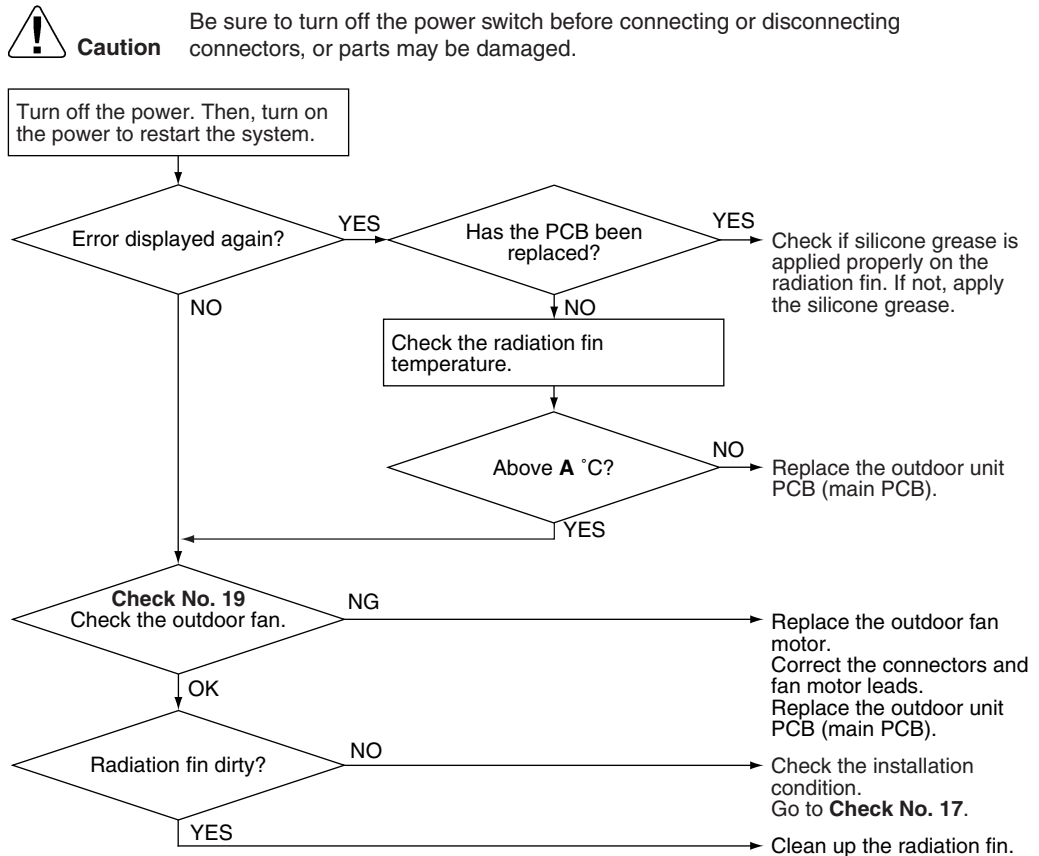

Note: Refer to Silicone Grease on Power Transistor / Diode Bridge on page 94 for details.

4.22 Output Overcurrent Detection

Error CodeU5

Method of Error Detection

An output overcurrent is detected by checking the current that flows in the inverter DC section.

Error Decision Conditions

- A position signal error occurs while the compressor is running.
 - A rotation speed error occurs while the compressor is running.
 - An output overcurrent signal is fed from the output overcurrent detection circuit to the microcomputer.
 - If the error repeats, the system is shut down.
 - Reset condition: Continuous run for about 11 minutes without any other error
-

Supposed Causes

- Poor installation condition
- Closed stop valve
- Defective power module
- Wrong internal wiring
- Abnormal power supply voltage
- Defective outdoor unit PCB
- Power supply voltage is not as specified.
- Defective compressor

Troubleshooting

Check No.15
Refer to P.83



Check No.17
Refer to P.86

Check No.18
Refer to P.86

Check No.22
Refer to P.88

 **Caution** Be sure to turn off the power switch before connecting or disconnecting connectors, or parts may be damaged.

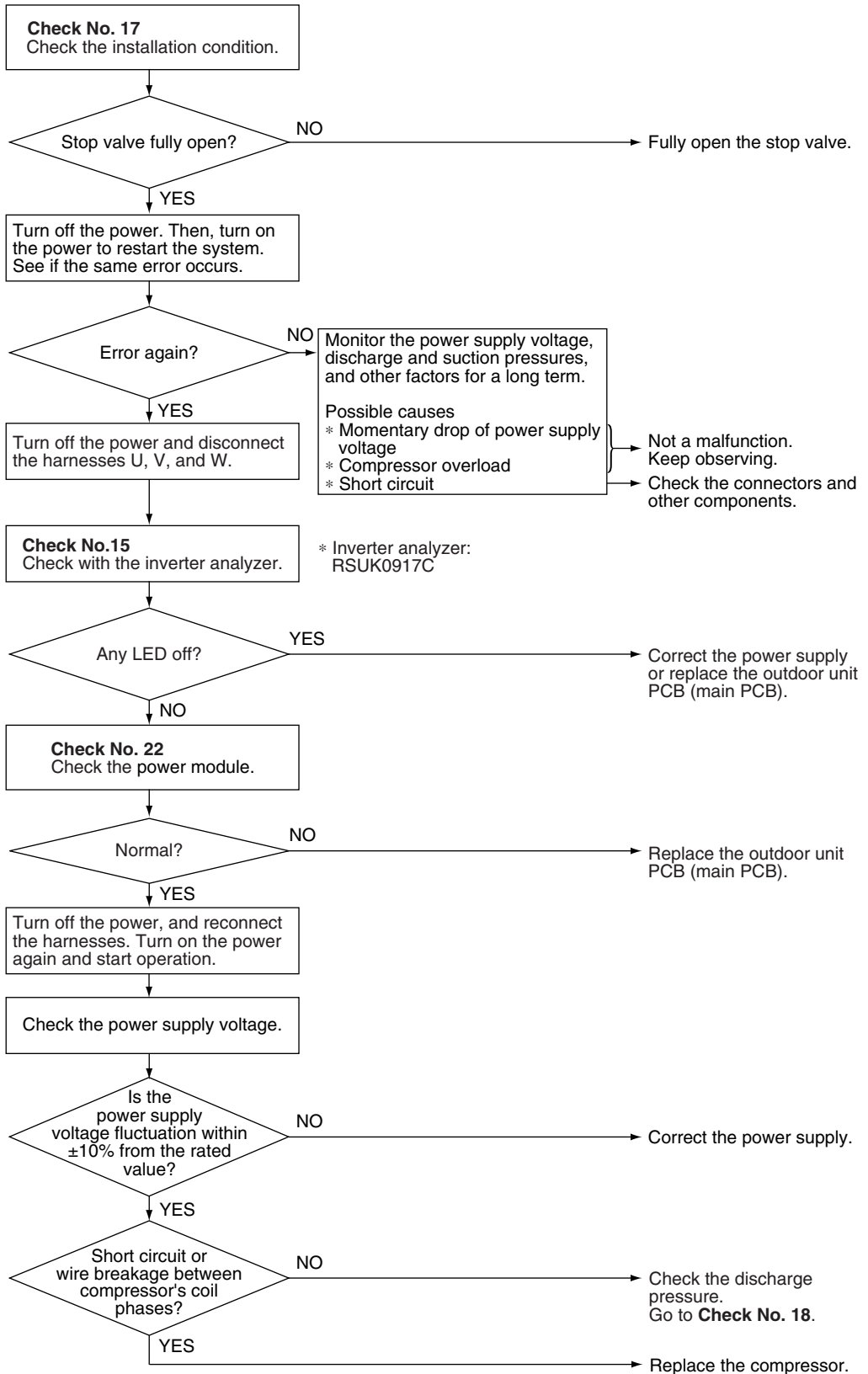
* An output overcurrent may result from wrong internal wiring. If the system is interrupted by an output overcurrent after the wires have been disconnected and reconnected for part replacement, check the wiring again.



(R22765)

5. Check

5.1 Thermistor Resistance Check

Check No.01

Disconnect the connectors of the thermistors from the PCB, and measure the resistance of each thermistor using a multimeter.

The data is for reference purpose only.

Thermistor temperature (°C)	Resistance (kΩ)	
	Room temperature thermistor	Other thermistors
-20	73.4	197.8
-15	57.0	148.2
-10	44.7	112.1
-5	35.3	85.60
0	28.2	65.93
5	22.6	51.14
10	18.3	39.99
15	14.8	31.52
20	12.1	25.02
25	10.0	20.00
30	8.2	16.10
35	6.9	13.04
40	5.8	10.62
45	4.9	8.707
50	4.1	7.176

(R25°C = 10 kΩ, B = 3435 K) (R25°C = 20 kΩ, B = 3950 K)

Room temperature thermistor

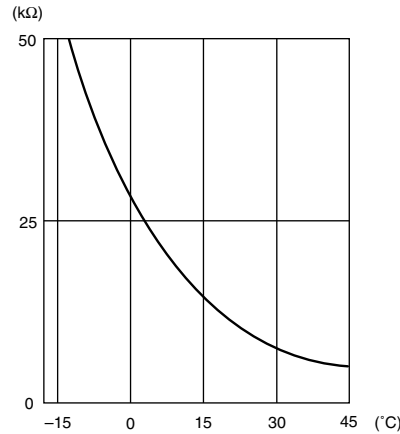

Other thermistors

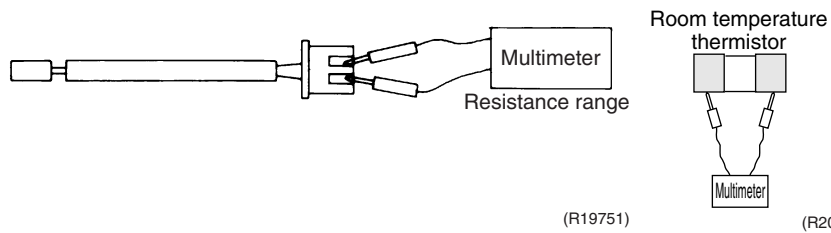
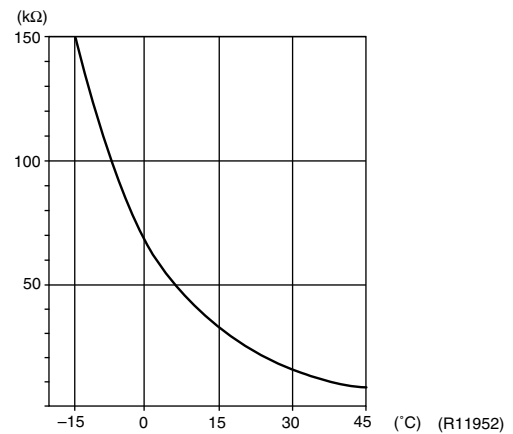

- When the room temperature thermistor is soldered on a PCB, remove the PCB from the control PCB to measure the resistance.
- When the connector of indoor heat exchanger thermistor is soldered on a PCB, remove the thermistor and measure the resistance.

5.2 Indoor Fan Motor Connector Output Check

Check No.03

- ◆ Fan motor wire breakdown / short circuit check
 1. Check the connector for connection.
 2. Turn the power off.
 3. Check if each resistance at the phases U - V and V - W is $90 \Omega \sim 100 \Omega$ (between the pins 12 - 9, and between 9 - 6).

- ◆ Motor control voltage check
 1. Check the connector for connection.
 2. Check the motor control voltage is generated (between the pins 2 - 3).

- ◆ Rotation pulse check
 1. Check the connector for connection.
 2. Turn the power on and stop the operation.
 3. Check if the Hall IC generates the rotation pulse 4 times when the fan motor is manually rotated once (between the pins 1 - 3).

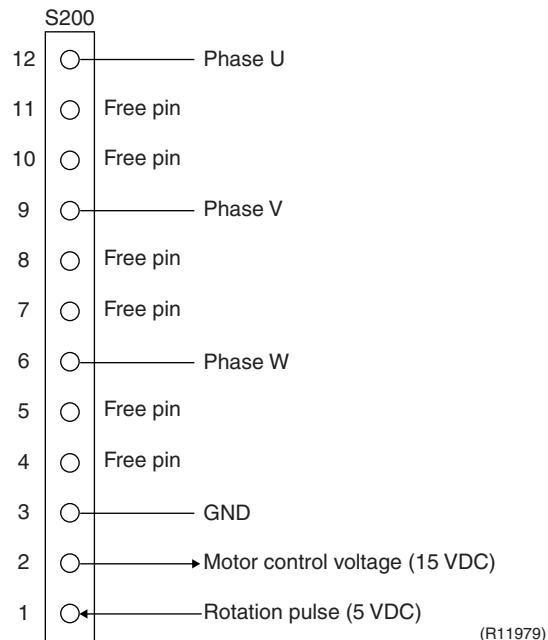

5.3 Power Supply Waveforms Check

Check No.11

Measure the power supply waveform between No. 1 and No. 2 on the terminal board, and check the waveform disturbance.

- Check if the power supply waveform is a sine wave (Fig.1).
- Check if there is waveform disturbance near the zero-cross (sections circled in Fig.2).

Fig.1

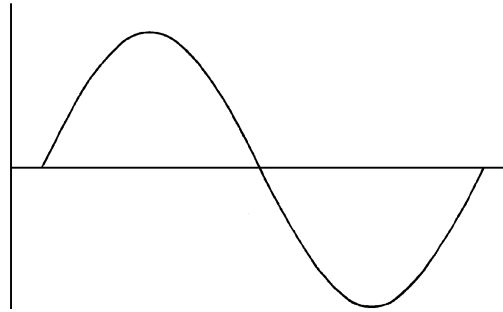

(R1736)

Fig.2

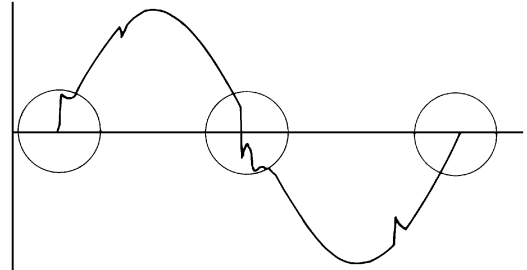

(R1444)

5.4 Electronic Expansion Valve Check

Check No.12

Conduct the followings to check the electronic expansion valve (EV).

1. Check if the EV connector is correctly connected to the PCB.
2. Turn the power off and on again, and check if the EV generates a latching sound.
3. If the EV does not generate a latching sound in the above step 2, disconnect the connector and check the continuity using a multimeter.
4. Check the continuity between the pins 1 - 6, 2 - 6, 3 - 6, and 4 - 6 (between the pins 1 - 5, 2 - 5, 3 - 5, 4 - 5 for the 5P connector models). If there is no continuity between the pins, the EV coil is faulty.
5. If the continuity is confirmed in step 3, the outdoor unit PCB (main PCB) is faulty.

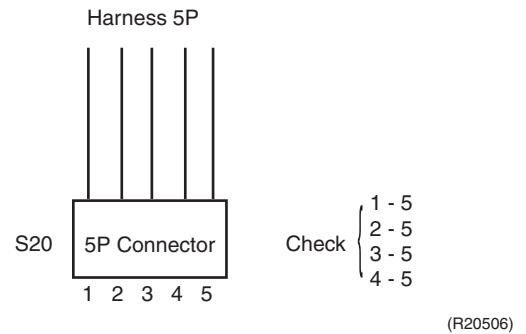
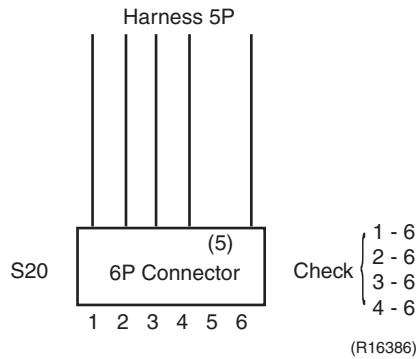

5.5 Four Way Valve Performance Check

Check No.13

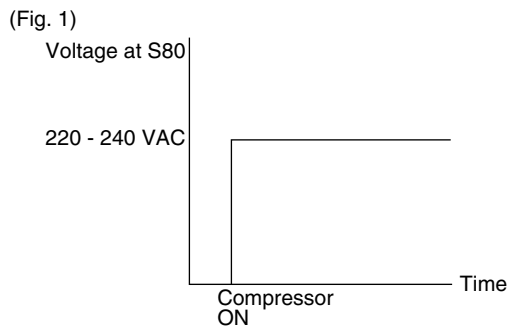
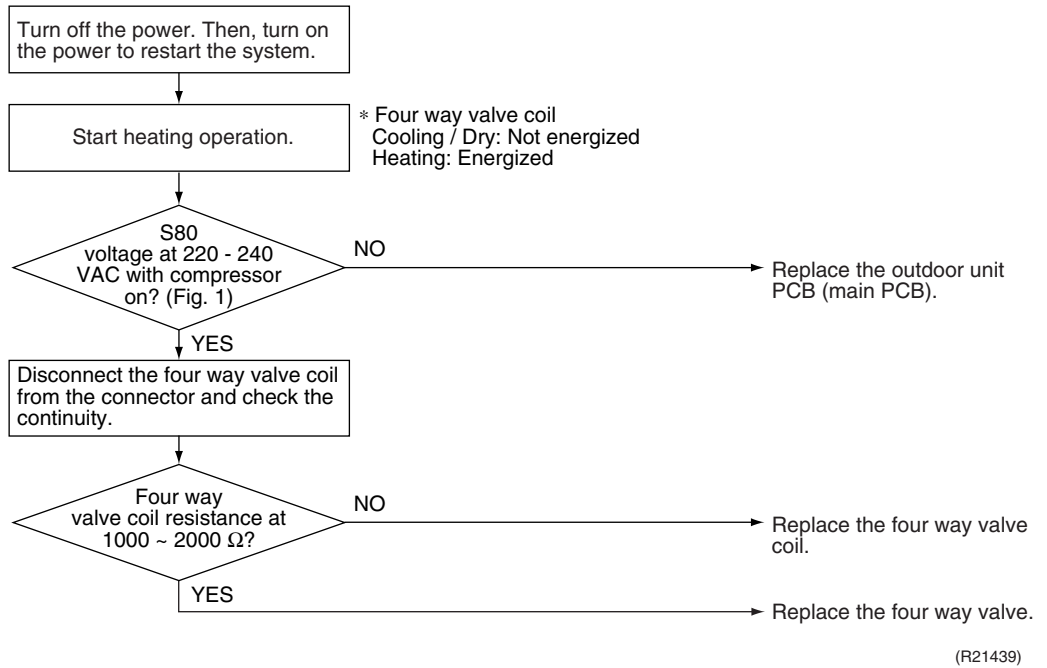

5.6 Inverter Unit Refrigerant System Check

Check No.14

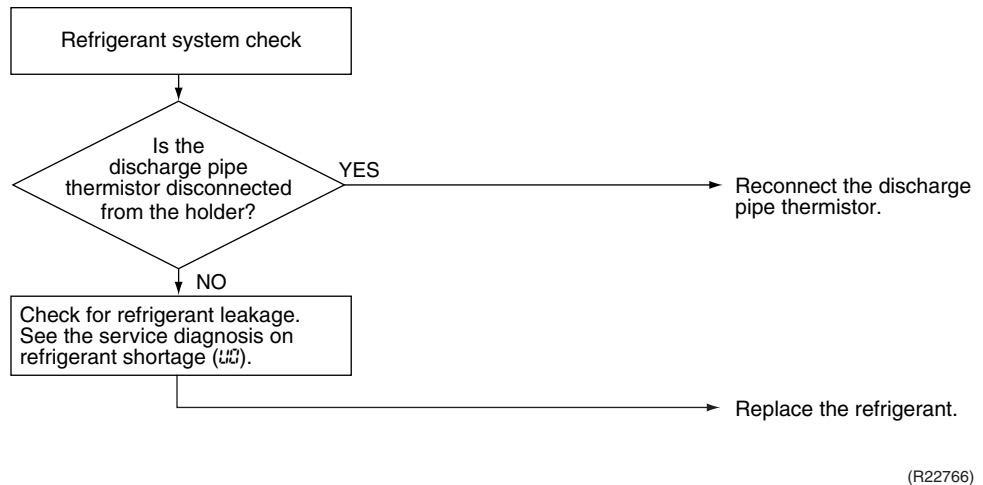

5.7 Inverter Analyzer Check

Check No.15

■ Characteristics

Inverter analyzer: RSUK0917C

If an abnormal stop occurs due to compressor startup failure or overcurrent output when using an inverter unit, it is difficult to judge whether the stop is caused by the compressor failure or some other failure (main PCB, power module, etc.). The inverter analyzer makes it possible to judge the cause of trouble easily and securely. (Connect an inverter analyzer as a quasi-compressor instead of compressor and check the output of the inverter)

■ Operation Method

Step 1

Be sure to turn the power off.

Step 2

Install an inverter analyzer instead of a compressor.

Note:

Make sure the charged voltage of the built-in smoothing electrolytic capacitor drops to 10 VDC or below before carrying out the service work.

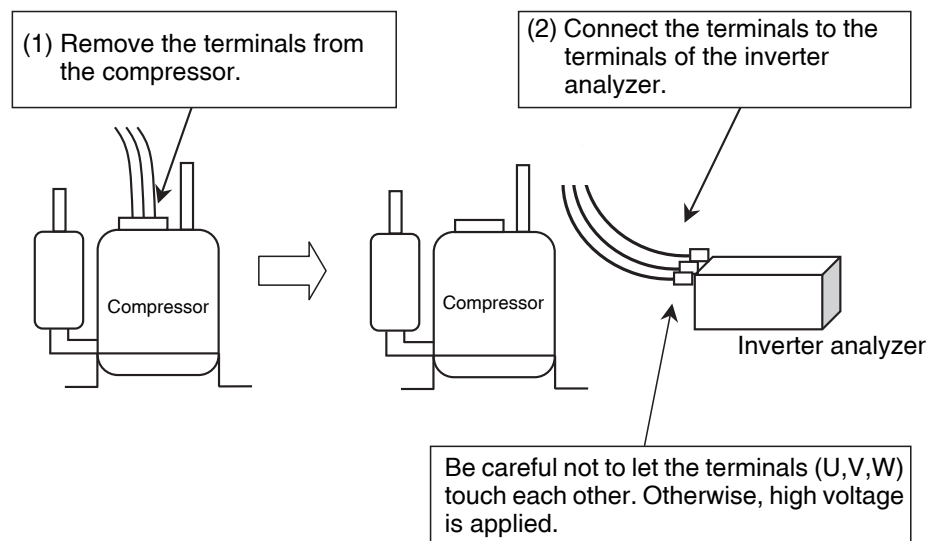

(R22731)

Reference:

If the terminals of the compressor are not FASTON terminals (difficult to remove the wire on the terminals), it is possible to connect wires available on site to the outdoor unit from output side of PCB. (Do not connect them to the compressor at the same time, otherwise it may result in incorrect detection.)

Step 3

Activate power transistor test operation from the indoor unit.

- (1) Turn the power on.
- (2) Press the center of the **TEMP** button and the **OFF** button on the remote controller at the same time.
- (3) Select **?** with the **TEMP** \wedge or **TEMP** \vee button.
- (4) Press the **FAN** button.
- (5) Press the **FAN ONLY** button to start the power transistor test operation.

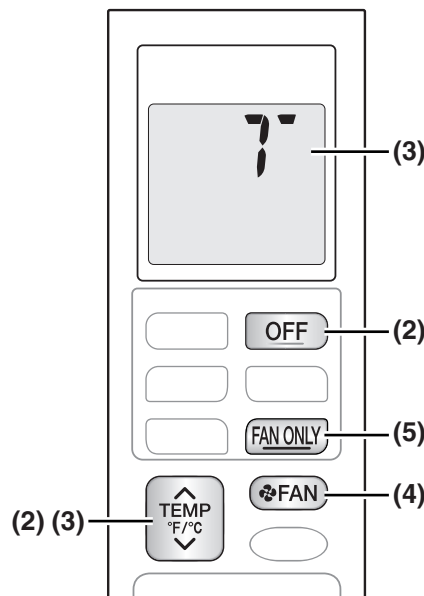

(R22990)

■ **Diagnose method (Diagnose according to 6 LEDs lighting status.)**

- (1) If all the LEDs are lit uniformly, the compressor is defective.
→ Replace the compressor.
- (2) If the LEDs are not lit uniformly, check the power module.
→ Refer to **Check No.22**.
- (3) If NG in **Check No.22**, replace the power module.
(Replace the main PCB. The power module is united with the main PCB.)
If OK in **Check No.22**, check if there is any solder cracking on the PCB.
- (4) If any solder cracking is found, replace the PCB or repair the soldered section.
If there is no solder cracking, replace the PCB.

**Caution**

- (1) When the output frequency is low, the LEDs blink slowly. As the output frequency increases, the LEDs blink quicker. (The LEDs look like they are lit.)
- (2) On completion of the inverter analyzer diagnosis, be sure to re-crimp the FASTON terminals. Otherwise, the terminals may be burned due to loosening.

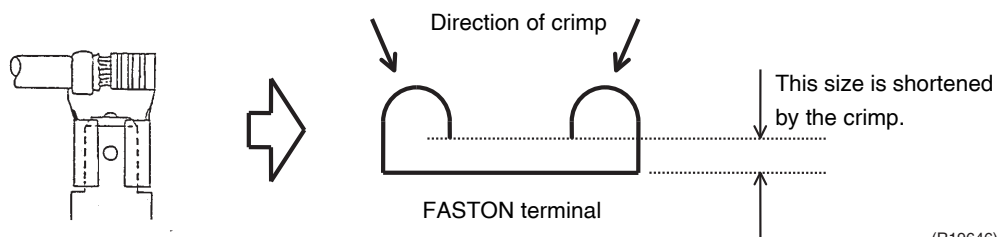

(R19646)

5.8 Rotation Pulse Check on the Outdoor Unit PCB

Check No.16

Make sure that the voltage of 320 + 100 V ~ 320 - 50 V is applied.

1. Set operation off and power off. Disconnect the connector S70 or S71.
2. Check that the voltage between the pins 4 - 7 is 320 VDC.
3. Check that the control voltage between the pins 3 - 4 is 15 VDC.
4. Check that the rotation command voltage between the pins 2 - 4 is 0 ~ 6.5 VDC.
5. Keep operation off and power off. Connect the connector S70 or S71.
6. Check whether 4 rotation pulses (0 ~ 15 VDC) are input at the pins 1 - 4 when the fan motor is rotated 1 turn by hand.

When the fuse is melted, check the outdoor fan motor for proper function.

If NG in step 2 → Defective PCB → Replace the outdoor unit PCB (main PCB).

If NG in step 4 → Defective Hall IC → Replace the outdoor fan motor.

If OK in both steps 2 and 4 → Replace the outdoor unit PCB (main PCB).

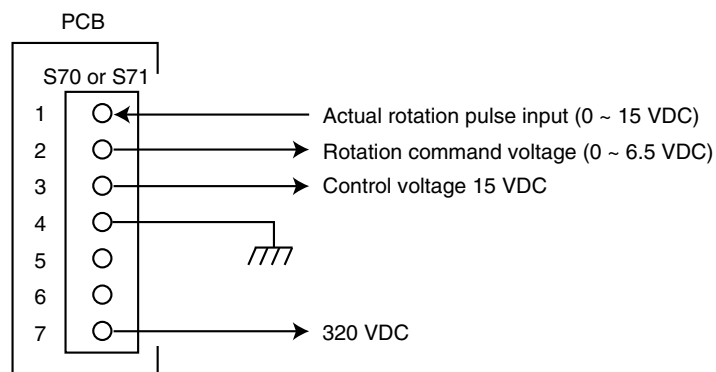

(R20507)

5.9 Installation Condition Check

Check No.17

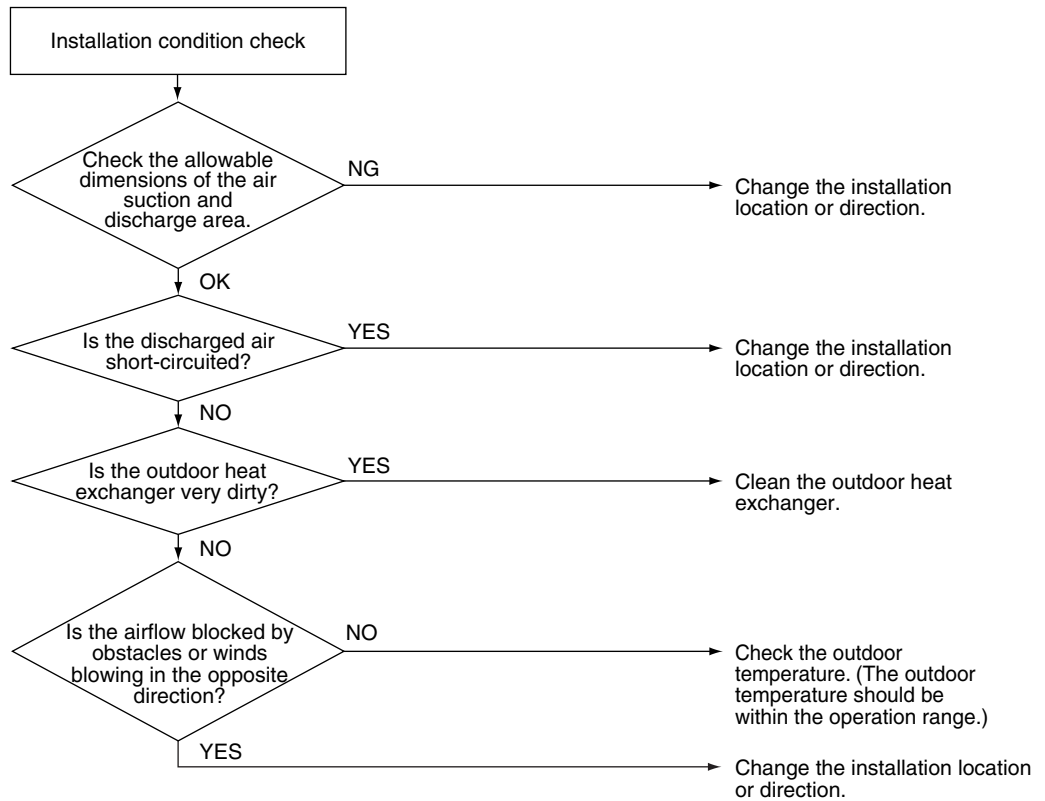

(R19401)

5.10 Discharge Pressure Check

Check No.18

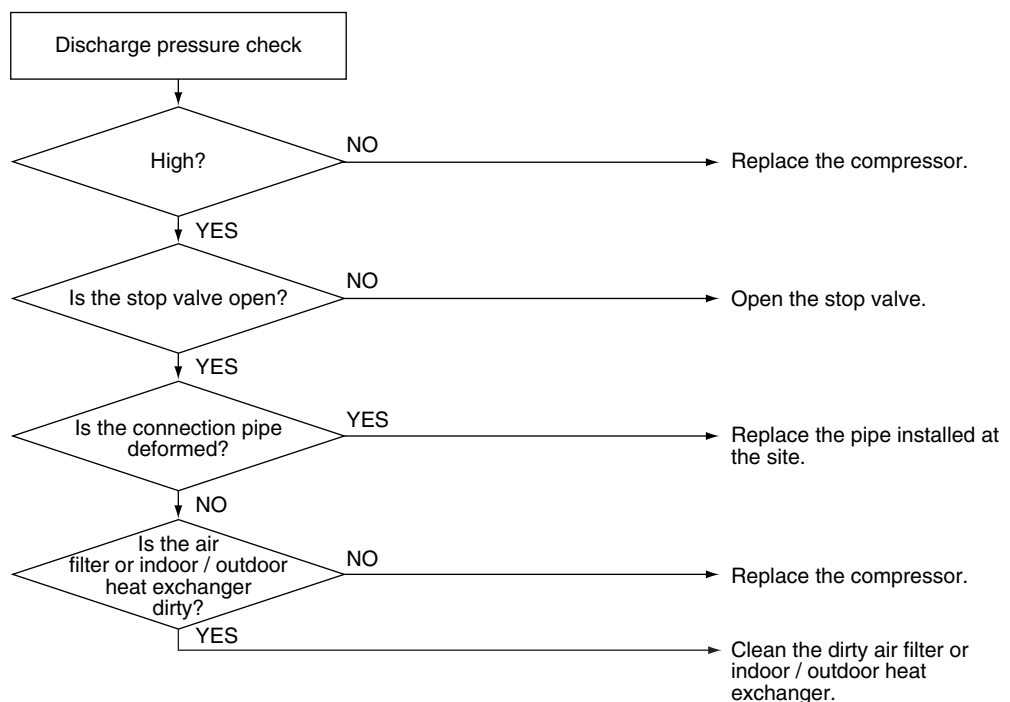

(R19385)

5.11 Outdoor Fan System Check

Check No.19

DC motor

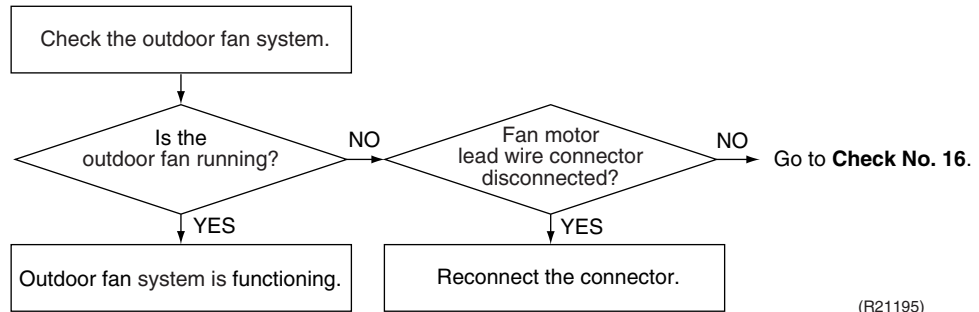

(R21195)

5.12 Main Circuit Short Check

Check No.20

Check to make sure that the voltage between (+) and (-) of the diode bridge (DB1) is about 0 V before checking.

- Measure the resistance between the pins of the DB1 referring to the table below.
- If the resistance is ∞ or less than 1 k Ω , short circuit occurs on the main circuit.

Positive terminal (+) of digital multimeter	~ (2, 3)	+ (4)	~ (2, 3)	- (1)
Negative terminal (-) of digital multimeter	+ (4)	~ (2, 3)	- (1)	~ (2, 3)
Resistance is OK.	several k Ω ~ several M Ω			
Resistance is NG.	0 Ω or ∞			

20/25/35 class

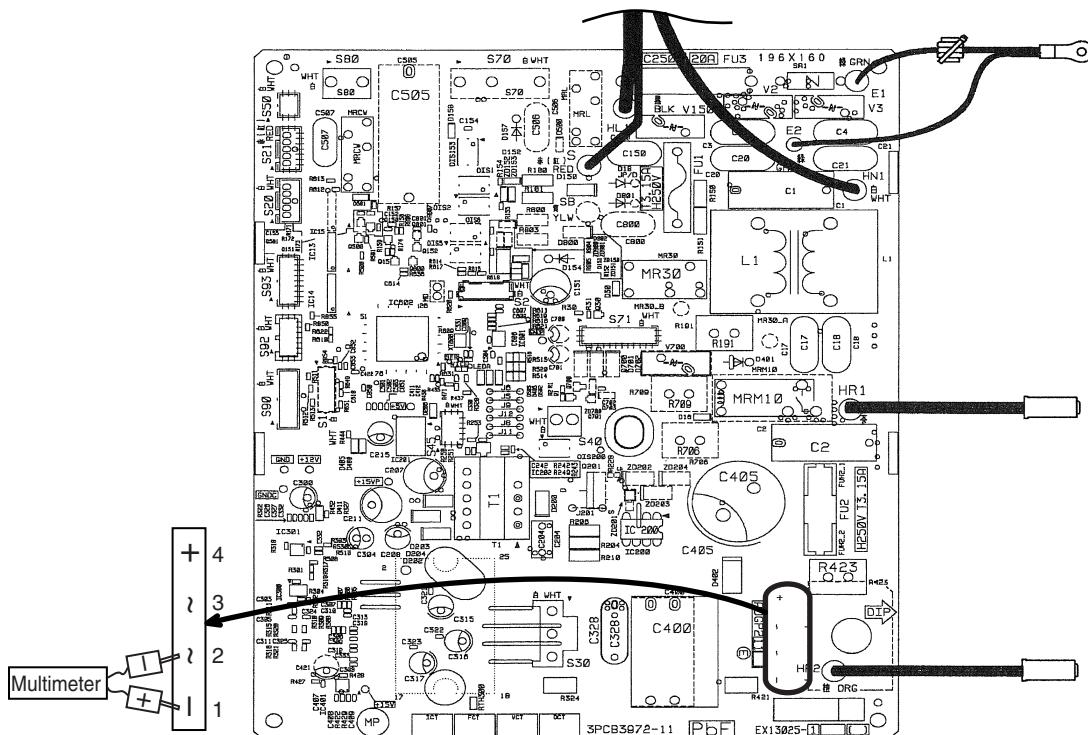

(R20698)

50/60/71 class

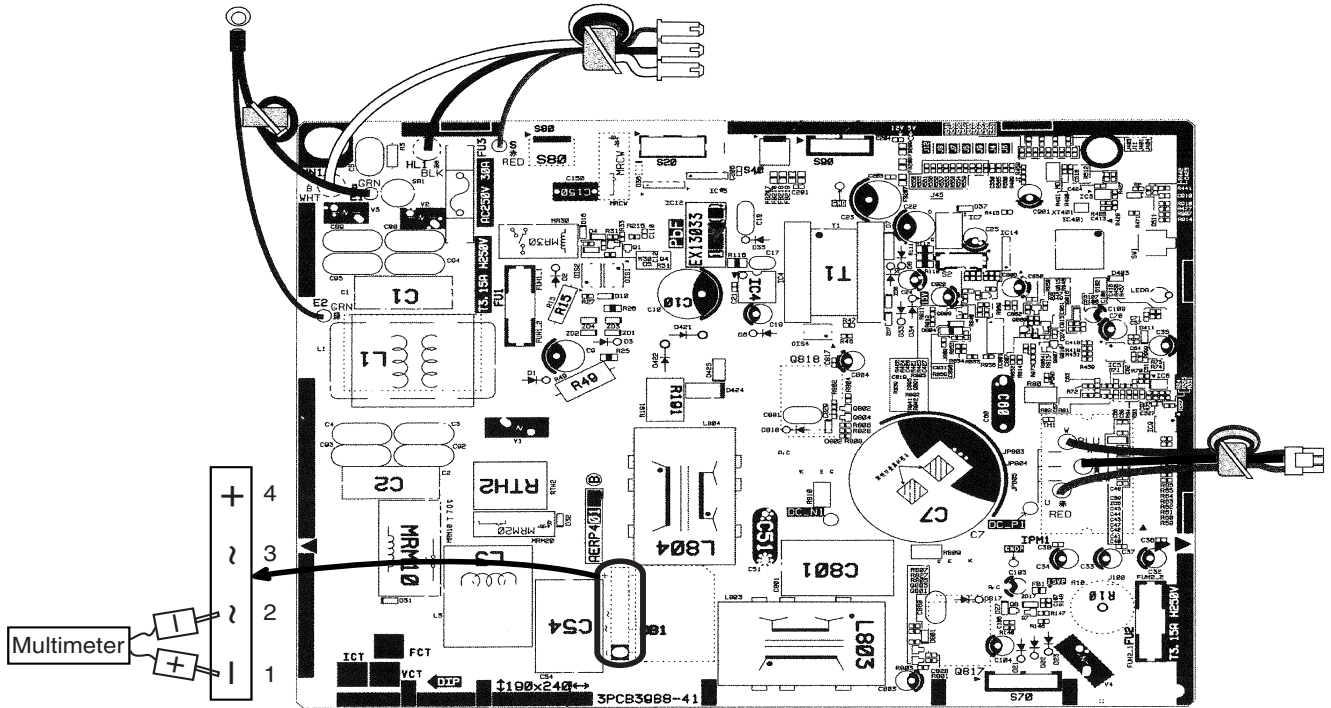

(R20701)

5.13 Power Module Check

Check No.22

Check to make sure that the voltage between (+) and (-) of the power module is about 0 V before checking.

- Disconnect the compressor harness connector from the outdoor unit PCB. To disengage the connector, press the protrusion on the connector.
- Follow the procedure below to measure resistance between the terminals of the power module and the terminals of the compressor with a multimeter. Evaluate the measurement results referring to the following table.

Positive terminal (+) of digital multimeter	Power module (+)	UVW	Power module (-)	UVW
Negative terminal (-) of digital multimeter	UVW	Power module (+)	UVW	Power module (-)
Resistance is OK.	several kΩ ~ several MΩ			
Resistance is NG.	0 Ω or ∞			

20/25/35 class

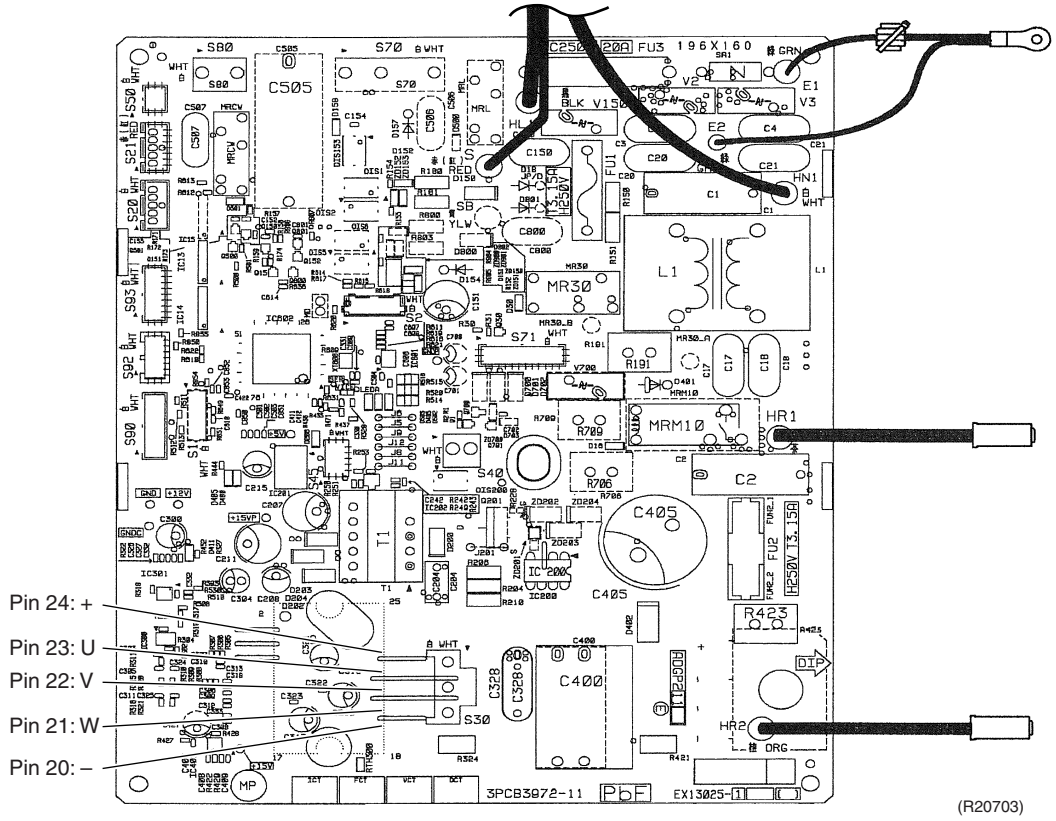

50/60/71 class

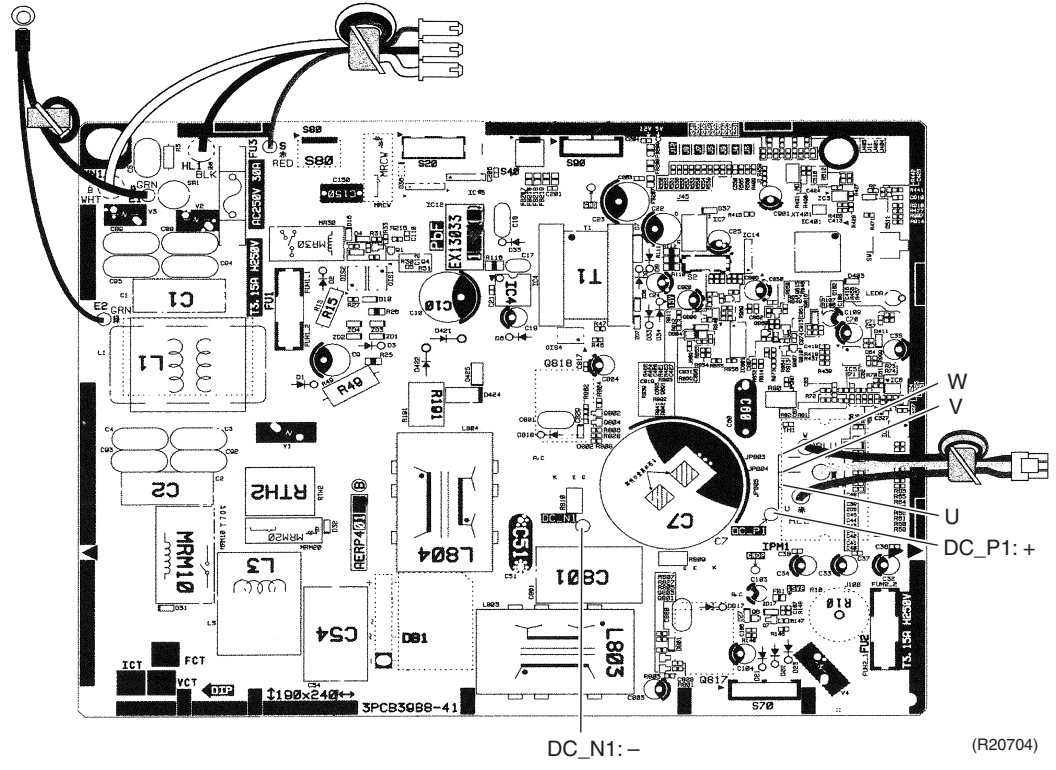

Part 7

Trial Operation and Field Settings

1. Tips for Servicing	91
1.1 Pump Down Operation	91
1.2 Forced Cooling Operation	91
2. Trial Operation	92
3. Field Settings	93
3.1 Temperature Display Switch	93
3.2 When 2 Units are installed in 1 Room	93
4. Silicone Grease on Power Transistor / Diode Bridge	94

1. Tips for Servicing

1.1 Pump Down Operation

Outline

In order to protect the environment, be sure to conduct pump down operation when relocating or disposing of the unit.

Detail

- 1) Remove the valve caps from the liquid stop valve and the gas stop valve.
- 2) Carry out forced cooling operation.
- 3) After 5 ~ 10 minutes, close the liquid stop valve with a hexagonal wrench.
- 4) After 2 ~ 3 minutes, close the gas stop valve and stop the forced cooling operation.

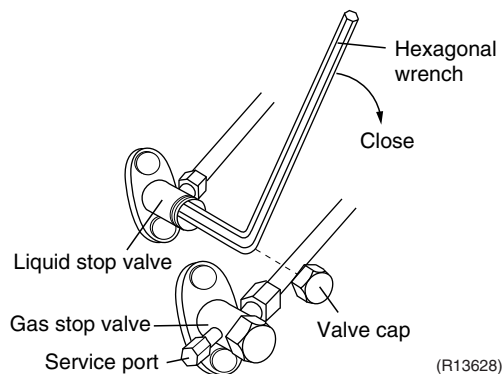

Refer to page 91 for forced cooling operation.

1.2 Forced Cooling Operation

Item	Forced Cooling
Conditions	The forced cooling operation is allowed when both of the following conditions are met. 1) The outdoor unit is not abnormal and not in the 3-minute standby mode. 2) The outdoor unit is not operating.
Start	Press the forced cooling operation ON/OFF button (SW1) on the indoor unit for 5 seconds.
Command frequency	20/25/35 class: 58 Hz 50/60/71 class: 30 Hz
End	The forced cooling operation ends when any of the following conditions is fulfilled. 1) The operation ends automatically after 15 minutes. 2) Press the forced cooling operation ON/OFF button (SW1) on the indoor unit again. 3) Press the ON/OFF button on the remote controller.
Others	Protection functions have priority over all other functions during forced cooling operation.

Indoor Unit

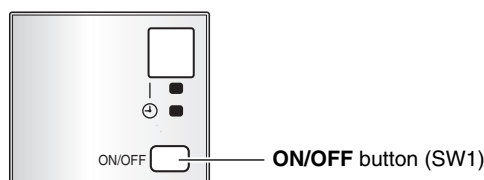

(R21069)

2. Trial Operation

Outline

Carry out the trial operation in accordance with the operation manual to ensure that all functions and parts, such as flap movement, are working properly.

Trial operation should be carried out in either cooling or heating operation.

Detail

1. Measure the power supply voltage and make sure that it falls within the specified range.
2. In cooling operation, select the lowest programmable temperature (18°C); in heating operation, select the highest programmable temperature (30°C).
 - ♦ Trial operation may be disabled in either operation mode depending on the room temperature.
 - ♦ After trial operation is complete, set the temperature to a normal level (26°C ~ 28°C in cooling, 20°C ~ 24°C in heating operation).
 - ♦ For protection, the system does not start for 3 minutes after it is turned off.

ARC480 Series

- (1) Press the center of the **TEMP** button and the **OFF** button on the remote controller at the same time.
- (2) Select ? (trial operation) with the **TEMP** ^ or **TEMP** v button.
- (3) Press the **FAN** button to enter the trial operation mode.
- (4) Press the **COOL** or **HEAT** button to start trial operation.
- (5) Trial operation terminates in approximately 30 minutes and switches into the normal mode.
To quit trial operation, press the **OFF** button.

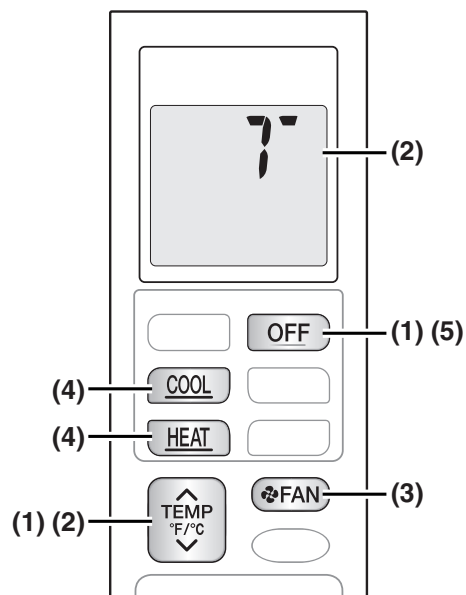

(R22991)

3. Field Settings

3.1 Temperature Display Switch

ARC466A6

- You can select Celsius or Fahrenheit for temperature display.
- Press the **TEMP▲** and **ON TIMER** buttons at the same time for 5 seconds to change the unit of temperature display.
- You can also change the unit of temperature display by pressing the **TEMP▲** and **▼** buttons at the same time for 5 seconds.

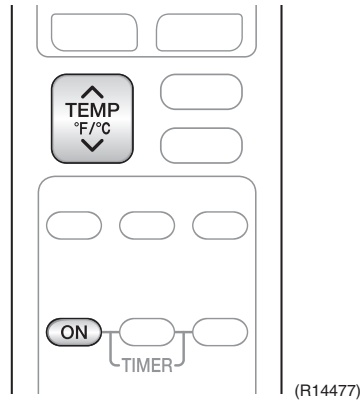

3.2 When 2 Units are installed in 1 Room

Outline

When 2 indoor units are installed in 1 room, 1 of the 2 indoor units and the corresponding wireless remote controller can be set for different addresses.

Procedure

- (1) Remove the battery cover of the remote controller and cut the address jumper.
- (2) Press the center of the **TEMP** button and the **OFF** button on the remote controller at the same time.
- (3) Select **R** (address setting) with the **TEMP ▲** or **TEMP ▼** button.
- (4) Press the **FAN** button to enter the address setting mode.
→ The indoor unit operation lamp blinks for 1 minute.
- (5) Press the indoor unit **ON/OFF** button while the operation lamp is blinking.
- (6) Press the **FAN** button on the remote controller for 5 seconds to return to the normal mode.

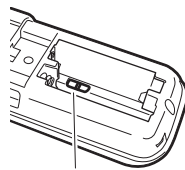

(1) Jumper

Jumper	Address
EXIST	1
CUT	2

(R21071)

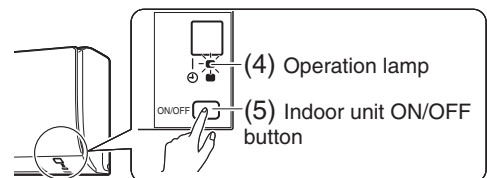
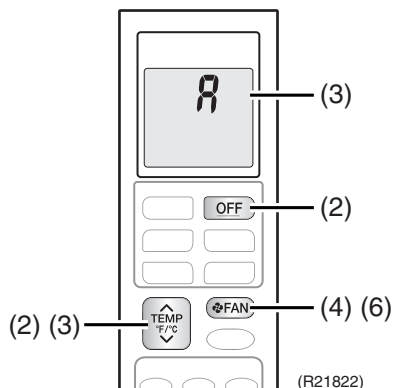

(R22992)

4. Silicone Grease on Power Transistor / Diode Bridge

Outline

Apply the specified silicone grease to the heat radiation part of a power transistor / diode bridge when you replace an outdoor unit PCB. The silicone grease encourages the heat radiation of a power transistor / diode bridge.

Detail

1. Wipe off the old silicone grease completely.
2. Apply the silicone grease evenly. See the illustrations below for examples of application.
3. Tighten the screws of the power transistor / diode bridge.
4. Make sure that the heat radiation parts are firmly contacted to the radiation fin.

Note: Smoke emission may be caused by bad heat radiation when the silicone grease is not appropriately applied.

- OK: Evenly applied

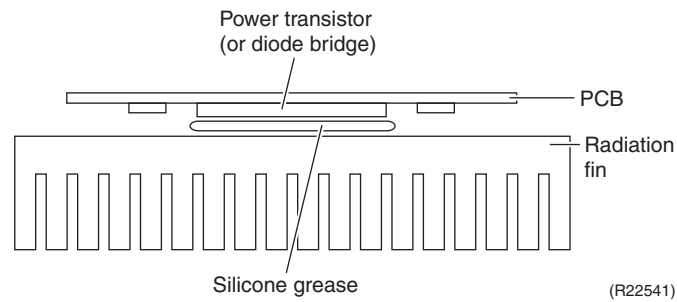

- NG: Not evenly applied

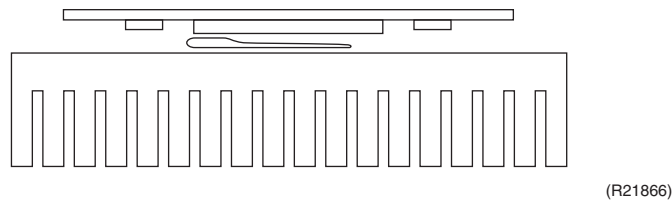

- NG: Foreign matter is stuck.

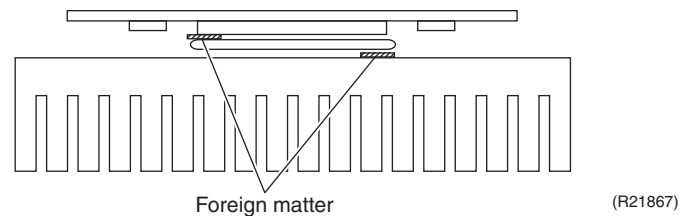

Part 8

Appendix

1. Piping Diagrams.....	96
1.1 Indoor Unit.....	96
1.2 Outdoor Unit.....	97
2. Wiring Diagrams.....	99
2.1 Indoor Unit.....	99
2.2 Outdoor Unit.....	101

1. Piping Diagrams

1.1 Indoor Unit

FTX20/25/35K(2)V1B, ATX20/25/35K(2)V1B

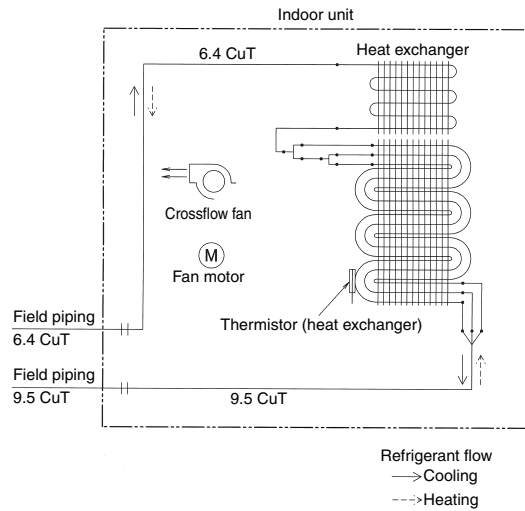

4D0094181

FTX50/60/71K(M/2)V1B

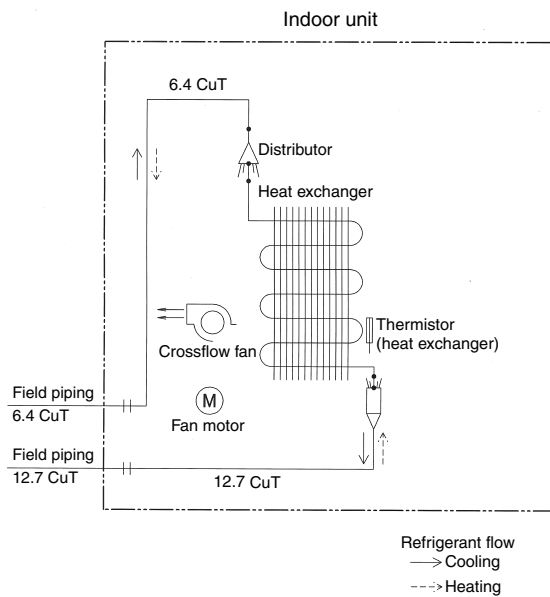

4D094179A

1.2 Outdoor Unit

RX20/25K2/5V1B, ARX20/25K2V1B

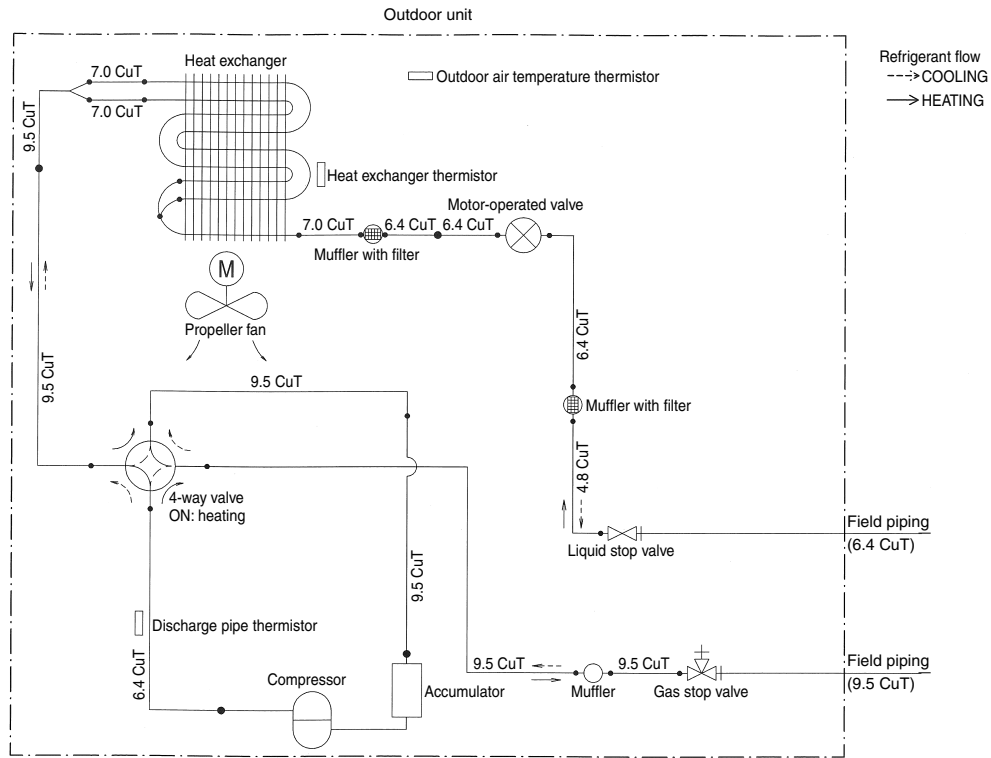

RX35K2/5V1B, ARX35K2V1B

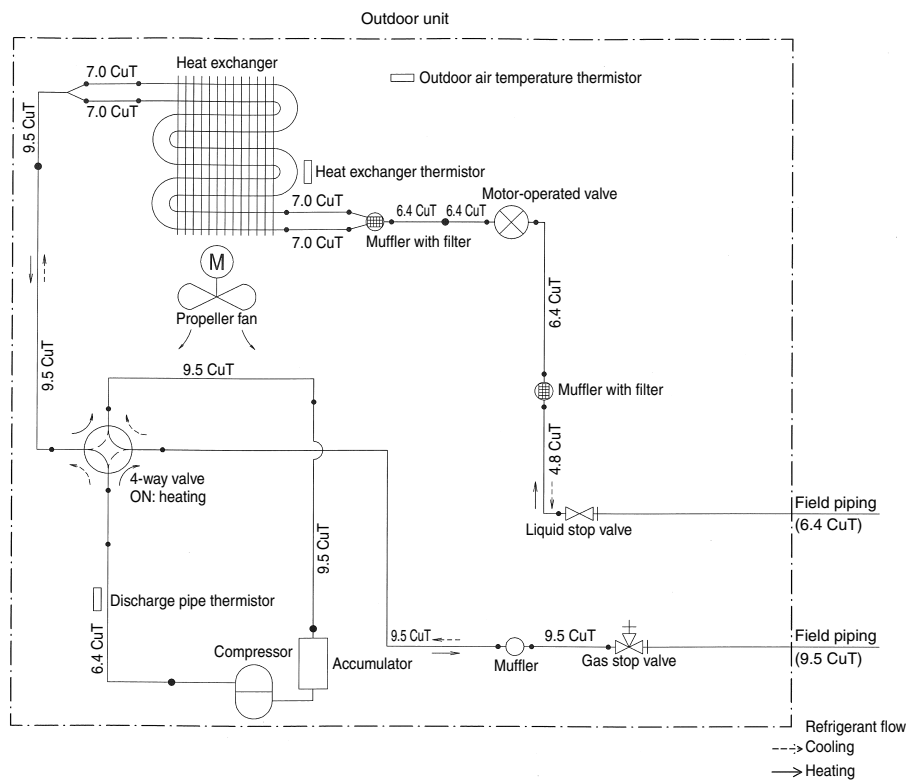

RX50K(2)V1B

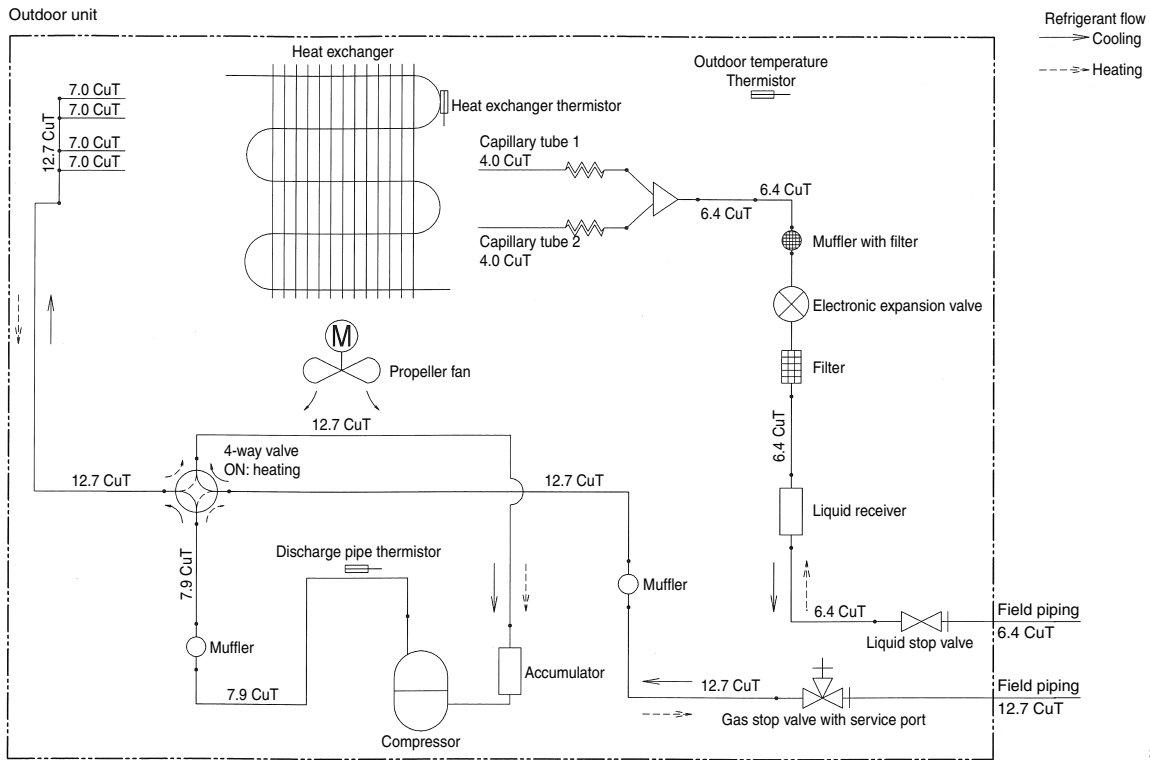

3D094281

RX60/71K(2)V1B

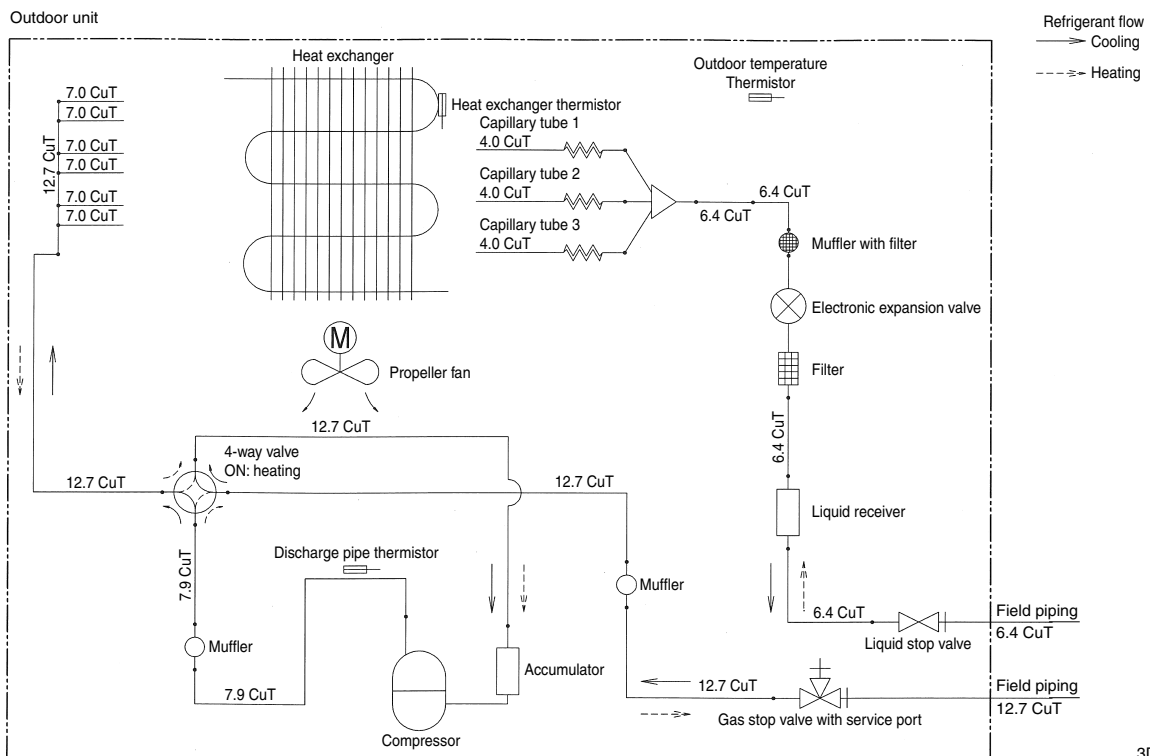

3D094282A

2. Wiring Diagrams

2.1 Indoor Unit

FTX20/25/35K(2)V1B, ATX20/25/35K(2)V1B

Wiring diagram

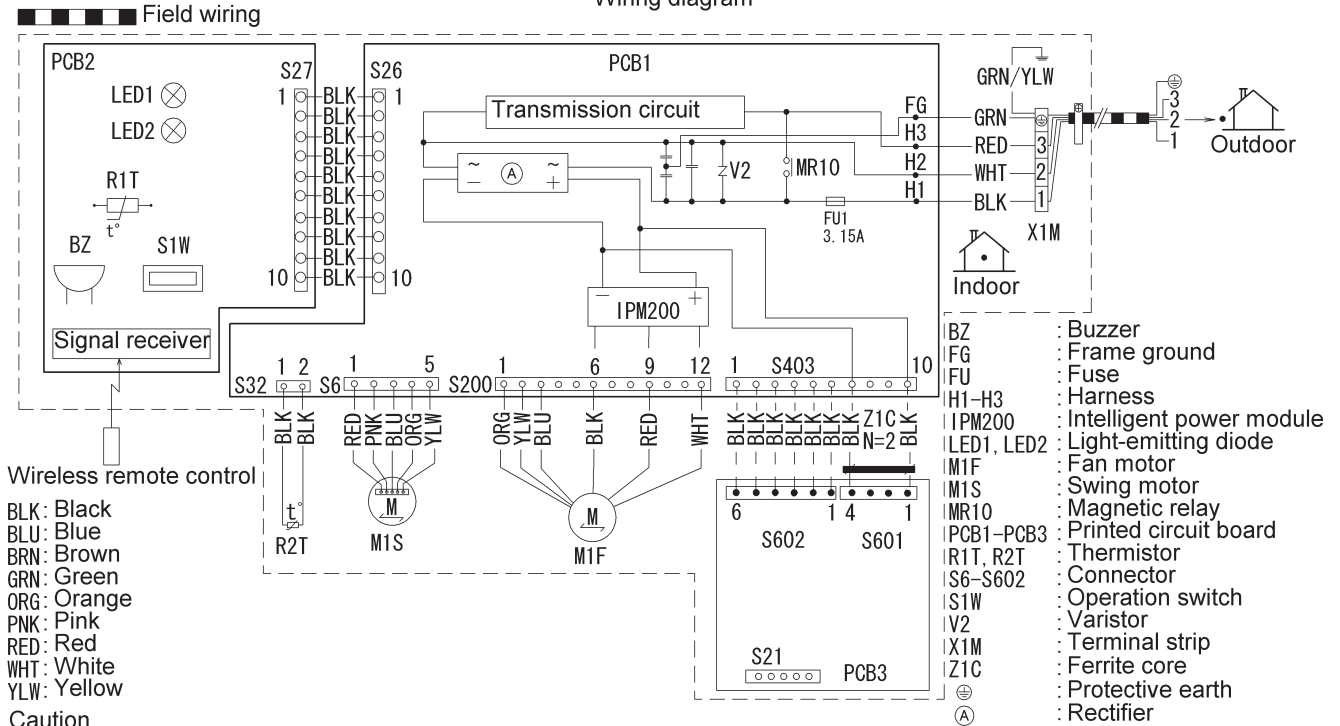

When the main power is turned off and then back on again, operation will resume automatically.

3D095416-1A



Note: PCB1: Control PCB
 PCB2: Display PCB
 Refer to Part 3 for Printed Circuit Board Connector Wiring Diagram.
 PCB3: Remote Control PCB BR069 (only available on A/FTX20-35K2V1B)

FTX50/60/71K(M/2)V1B

Wiring diagram

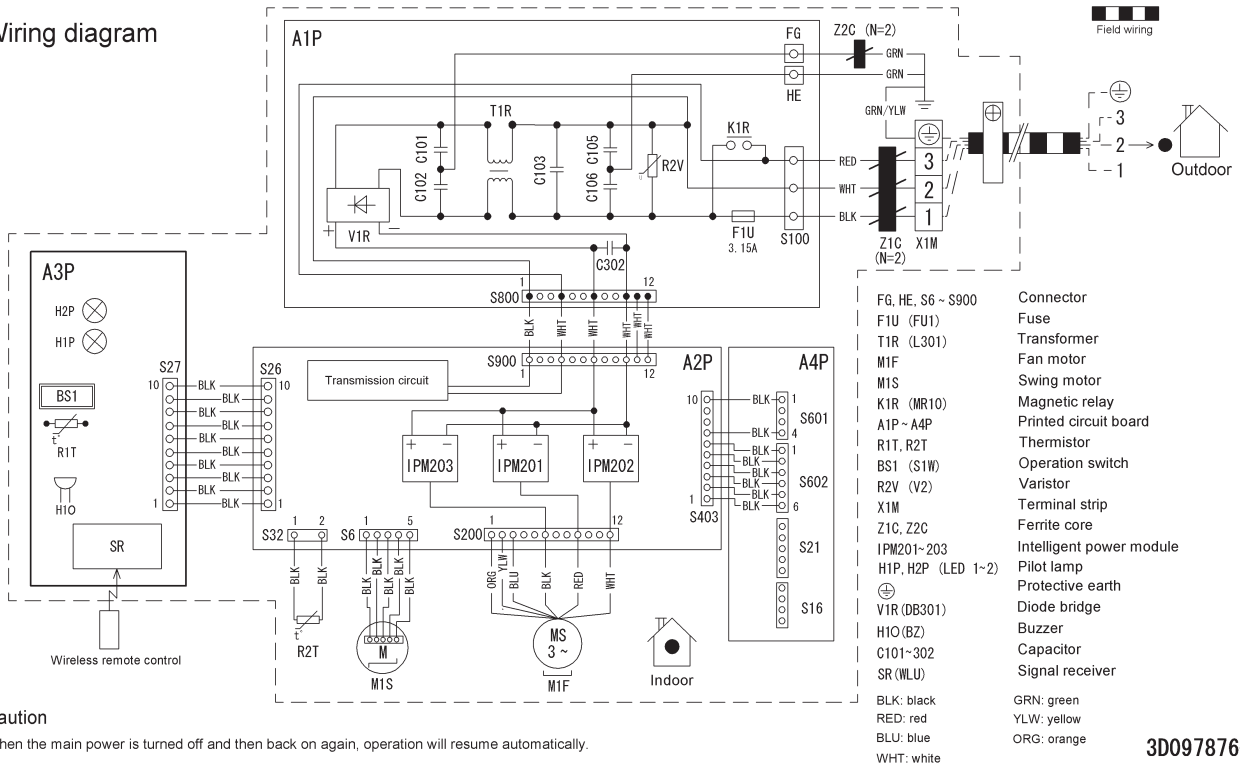

Caution

When the main power is turned off and then back on again, operation will resume automatically.



Note: PCB A1P: Filter PCB
 PCB A2P: Control PCB
 PCB A3P: Display PCB
 Refer to Part 3 for Printed Circuit Board Connector Wiring Diagram.
 PCB A4P: Remote Control PCB BR069 (only available on FTX50~71KM)

3D097876-1

2.2 Outdoor Unit

RX20/25/35K2/5V1B, ARX20/25/35K2V1B

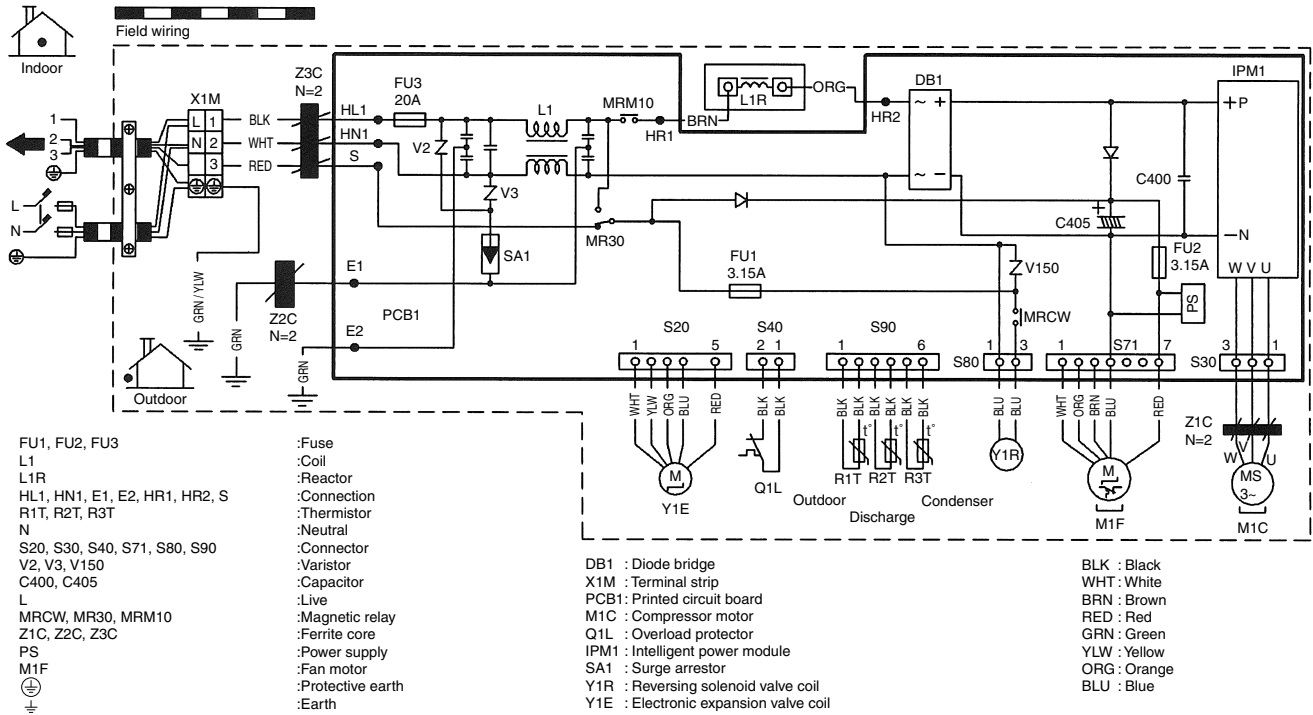

For the power requirements, refer to the nameplate.

4D090152



Note: PCB1: Main PCB
Refer to Part 3 for Printed Circuit Board Connector Wiring Diagram.

RX50/60/71K(2)V1B

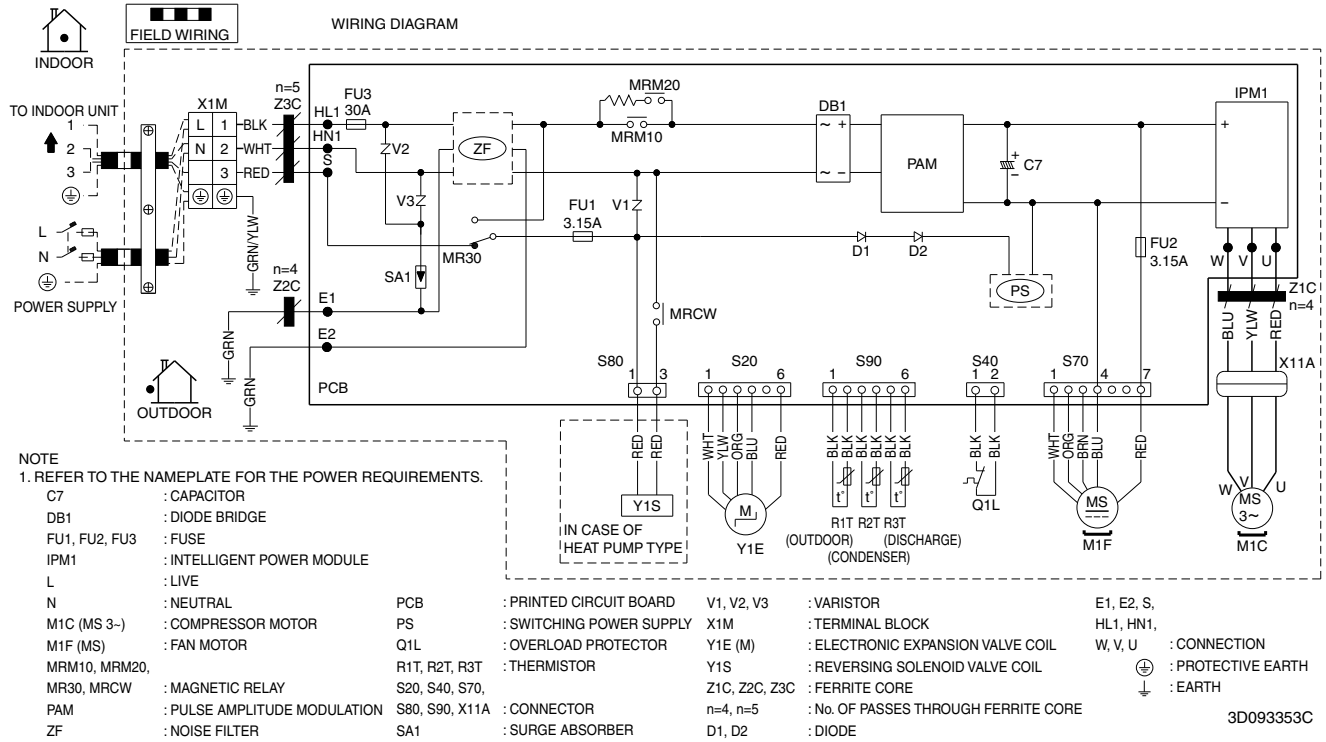

Note: PCB: Main PCB
 Refer to Part 3 for Printed Circuit Board Connector Wiring Diagram.

Warning

- Daikin products are manufactured for export to numerous countries throughout the world. Prior to purchase, please confirm with your local authorised importer, distributor and/or retailer whether this product conforms to the applicable standards, and is suitable for use, in the region where the product will be used. This statement does not purport to exclude, restrict or modify the application of any local legislation.
- Ask a qualified installer or contractor to install this product. Do not try to install the product yourself. Improper installation can result in water or refrigerant leakage, electrical shock, fire or explosion.
- Use only those parts and accessories supplied or specified by Daikin. Ask a qualified installer or contractor to install those parts and accessories. Use of unauthorised parts and accessories or improper installation of parts and accessories can result in water or refrigerant leakage, electrical shock, fire or explosion.
- Read the user's manual carefully before using this product. The user's manual provides important safety instructions and warnings. Be sure to follow these instructions and warnings.

If you have any enquiries, please contact your local importer, distributor and/or retailer.

Cautions on product corrosion

1. Air conditioners should not be installed in areas where corrosive gases, such as acid gas or alkaline gas, are produced.
2. If the outdoor unit is to be installed close to the sea shore, direct exposure to the sea breeze should be avoided. If you need to install the outdoor unit close to the sea shore, contact your local distributor.

Dealer**DAIKIN INDUSTRIES, LTD.**

Head Office:
Umeda Center Bldg., 2-4-12, Nakazaki-Nishi,
Kita-ku, Osaka, 530-8323 Japan

Tokyo Office:
JR Shinagawa East Bldg., 2-18-1, Konan,
Minato-ku, Tokyo, 108-0075 Japan

<http://www.daikin.com/products/ac/>

©All rights reserved