

Air Conditioning
Technical Data

FDBQ-B



TABLE OF CONTENTS

FDBQ-B

1	Features	2
2	Specifications	3
	Technical Specifications	3
	Electrical Specifications	3
3	Options	4
4	Dimensional drawings	5
5	Piping diagrams	6
6	Wiring diagrams	7
	Wiring Diagrams - Single Phase	7
7	Sound data	8
	Sound Pressure Spectrum	8
8	Fan characteristics	9
9	Installation	10
	Installation Method	10

1 Features

Designed for hotel applications

- Compact unit (230mm high & 652mm deep), can easily be mounted in narrow ceiling voids
- Discretely concealed in the ceiling: only the suction and discharge grilles are visible
- Whisper quiet operation: down to 28dBA sound pressure level
- Flexible installation, as the air suction direction can be altered from rear to bottom suction
- For easy mounting, the drain pan can be located to the left or right of the unit



Home leave operation



Fan only



Auto cooling-heating changeover



Whisper quiet



Fan speed steps



Dry programme



Air filter



Weekly timer



Wired remote control



Auto-restart



Self diagnosis



Multi model application



VRV for residential application

2 Specifications

2-1 Technical Specifications				FDBQ25B	
Casing	Material			Zinc coated low carbon steel	
Dimensions	Unit	Height/Width/Depth	mm	230/652/502	
	Packed unit	Height/Width/Depth	mm	301/753/584	
Weight	Unit		kg	17.0	
	Packed unit		kg	18.0	
Heat exchanger	Rows	Quantity		2	
	Fin pitch		mm	1.40	
	Passes	Quantity		2	
	Face area		m ²	0.108	
	Stages	Quantity		12	
	Empty tubeplate hole	Quantity		0	
	Tube type			ø7 Hi-XA	
	Fin	Type		Rhombus	
	Length		mm	430	
	Air filter	Type			Resin net with mold resistance
Fan	Type			Sirocco fan	
	Quantity			1	
	Air flow rate	Cooling	High	m ³ /min	6.50
			Low	m ³ /min	5.20
		Heating	High	m ³ /min	6.95
Low			m ³ /min	5.20	
Fan motor	Quantity			1	
	Drive			Direct drive	
	Speed	Steps		2	
	Output	High	W	10	
Sound power level	Cooling		dBA	55	
	Heating		dBA	55	
Sound pressure level	Cooling	High/Low	dBA	35.0/28.0	
	Heating	High/Low	dBA	35.0/29.0	
Control systems	Wired remote control			BRC1D52 / BRC1E52A/B	
Refrigerant	Type			R-410A	
Piping connections	Liquid	OD		6.35	
	Gas	OD		9.52	
	Drain			27.2	
Temperature control				Microprocessor thermostat for cooling and heating	

Standard Accessories : Installation and operation manual; Quantity : 1;

Standard Accessories : Suction air filter; Quantity : 1;

2-2 Electrical Specifications				FDBQ25B
Power supply	Name			V1
	Phase			1~
	Frequency		Hz	50
	Voltage		V	230
Voltage range	Max.		%	10
	Min.		%	-10
Current	Nominal running current (RLA) - 50Hz	Cooling	A	0.200
		Heating	A	0.200
Power supply intake				Outdoor unit only

Notes

Sound values are measured in a semi-anechoic room.

Sound pressure level is a relative value, depending on the distance and acoustic environment. For more details, please refer to the sound level drawings.

The sound power level is an absolute value indicating the power which a sound source generates.

3 Options

3 - 1 Options

3

FDBQ_B

Operation control

Nr.	Item	Type
1	Remote control	Wired
2	Optional PCB for external electric heaters, humidifiers and/or hour meters	
3	Simplified remote control (with operation mode selector button)	
4	Simplified remote control (without operation mode selector button)	
5	Digital input adaptor	

FDBQ25
BRC1D52
BRC1E53A7 (*1)
BRC1E53B7 (*2)
BRC1E53C7 (*3)(*6)
EKRP1B2
BRC2E52C7 (*4)(*6)
BRC3E52C7 (*4)(*6)
BRP7A54 (*5)

(*1) Included languages are: English, German, French, Italian, Spanish, Portuguese, and Dutch.

(*2) Included languages are: English, Czech, Croatian, Hungarian, Slovenian, Romanian, and Bulgarian.

(*3) Included languages are: English, Russian, Greek, Turkish, Polish, Albanian, and Slovak.

(*4) Included languages are:

Language pack 1: English, German, French, Dutch, Spanish, Italian, and Portuguese.

With PC cable EKPCAB3 in combination with the Updater PC software, you can additionally change the language to:

Language pack 2: English, Bulgarian, Croatian, Czech, Hungarian, Romanian, and Slovenian.

Language pack 3: English, Greek, Polish, Russian, Serbian, Slovak, and Turkish.

(*5) Only possible in combination with BRC2/3E52C7 or BRC1E53A/B/C7.

(*6) Language pack 3 of controller BRC1E53C7 is different from that of controller BRC2/3E52C7.

4TW25859-1H

4 Dimensional drawings

4 - 1 Dimensional Drawings

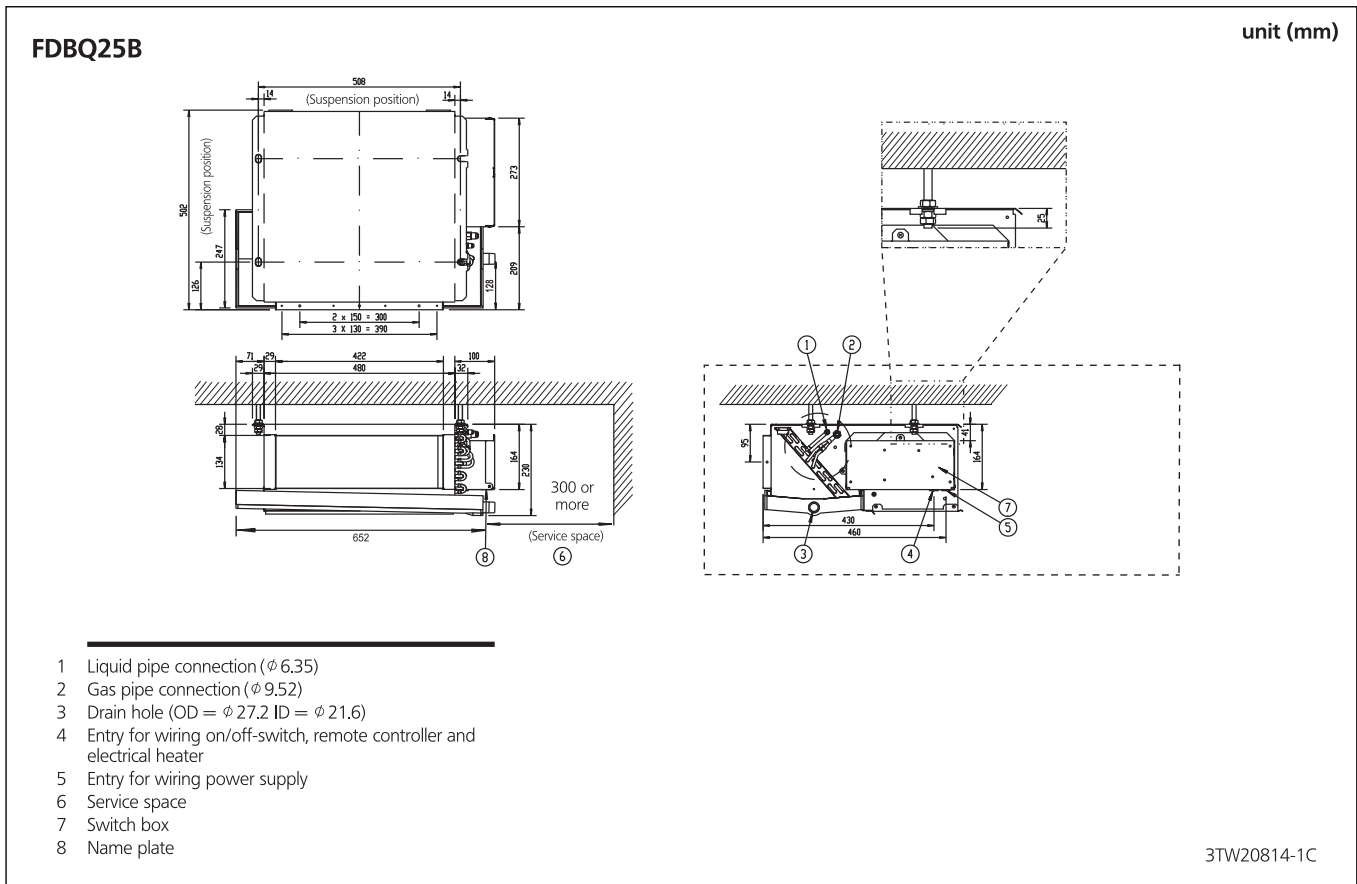

5 Piping diagrams

5 - 1 Piping Diagrams

5

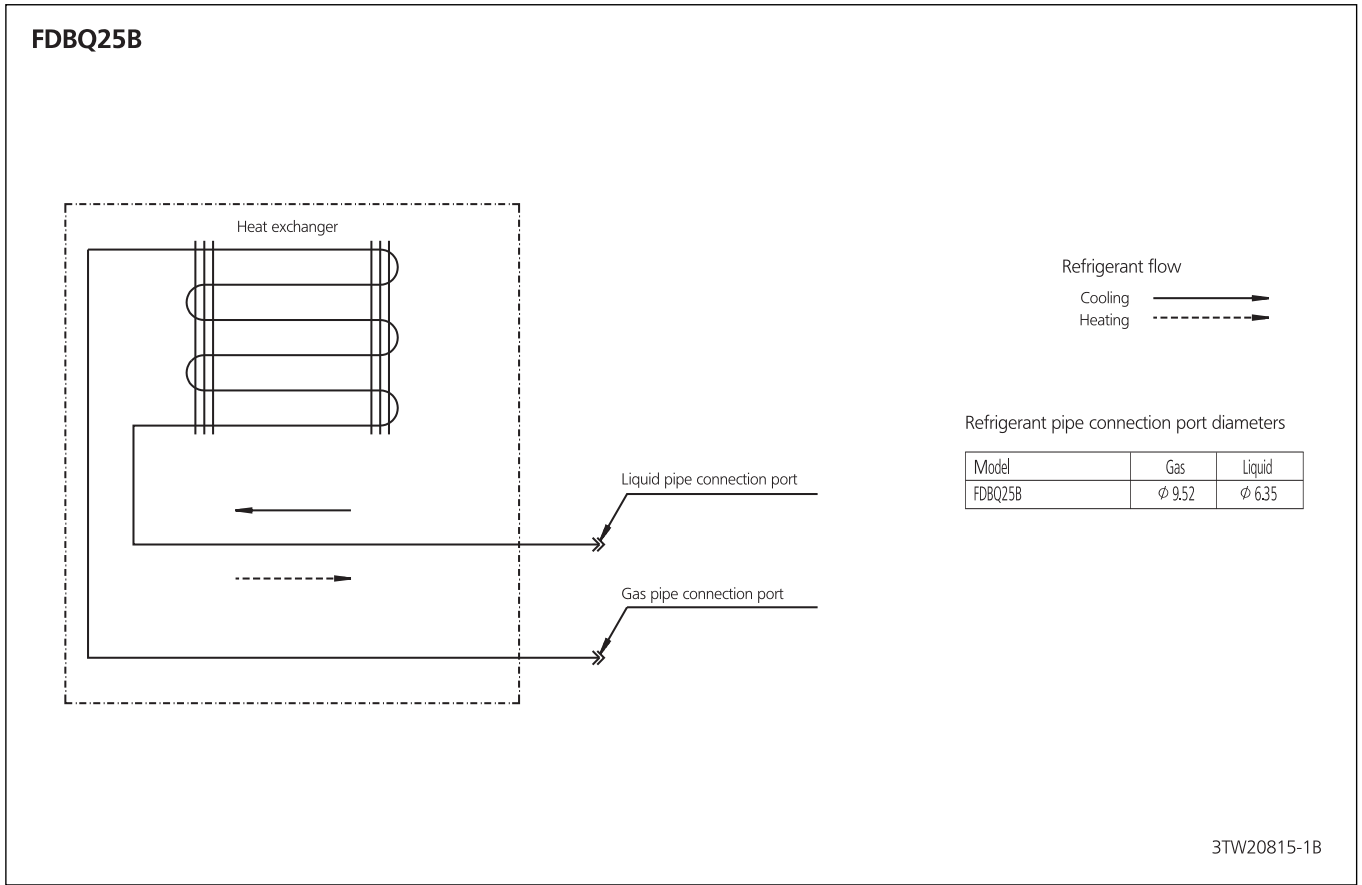

6

6 Wiring diagrams

6 - 1 Wiring Diagrams - Single Phase

FDBQ25B

A1P	Printed circuit board
T1R	Power supply transformer (transformer 220-240V/21.8V)
C1R	Capacitor (fan)
F1U	Fuse (5A, 250V)
F1T	Thermal fuse (152°C) (M1F embedded)
HAP	Light emitting diode (service monitor green)
M1F	Motor (fan)
R1T	Thermistor (Air)
R2T	Thermistor (Liquid)
R3T	Thermistor (Coil)
RyF1-4	Magnetic relay (fan)
SS1	Selector switch (emergency)
X1M	Terminal strip
X2M	Terminal strip
RC	Signal receiver circuit
TC	Signal transmission circuit
Adapter for wiring	
RyH	Magnetic relay
Q1L	Thermal protector
Connector for optional parts	
X60A, X61A	Connector (interface adapter for SKY AIR / US series)
X33A	Connector (adapter for wiring)
X35A	Connector (group control adapter)
X40A	Connector (remote ON/OFF forced OFF)
Field supply	
K1R	Magnetic relay
EH	Electrical heater

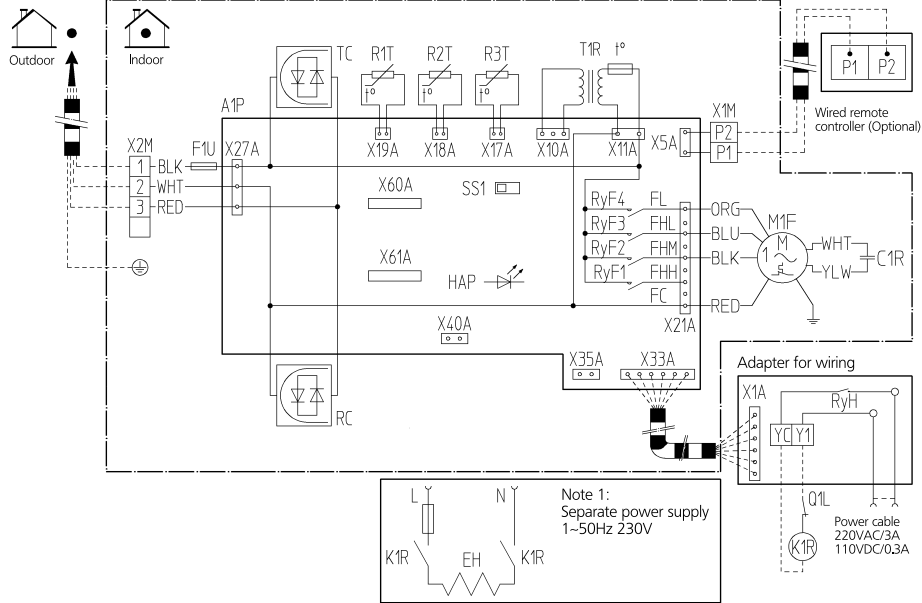

Notes

- 1 When using the central remote control, see manual for connection to the unit.
- 2 The remote controller model varies according to the combination system. See technical materials and catalogues, etc. before connecting.

- : Field wiring
- : Terminal
- : Connector
- : Wire clamp
- ⊕ : Protective earth (screw)

- Colours**
- BLK : Black
 - ORG : Orange
 - WHT : White
 - BLU : Blue
 - RED : Red

2TW25856-1B

7 Sound data

7 - 1 Sound Pressure Spectrum

7

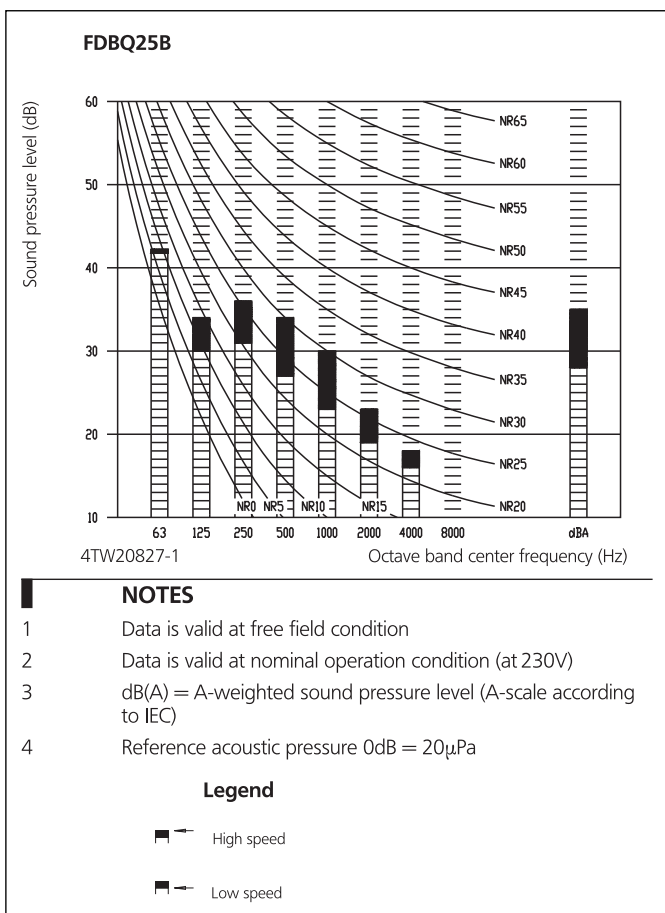

8 Fan characteristics

8 - 1 Fan Characteristics

FDBQ25B

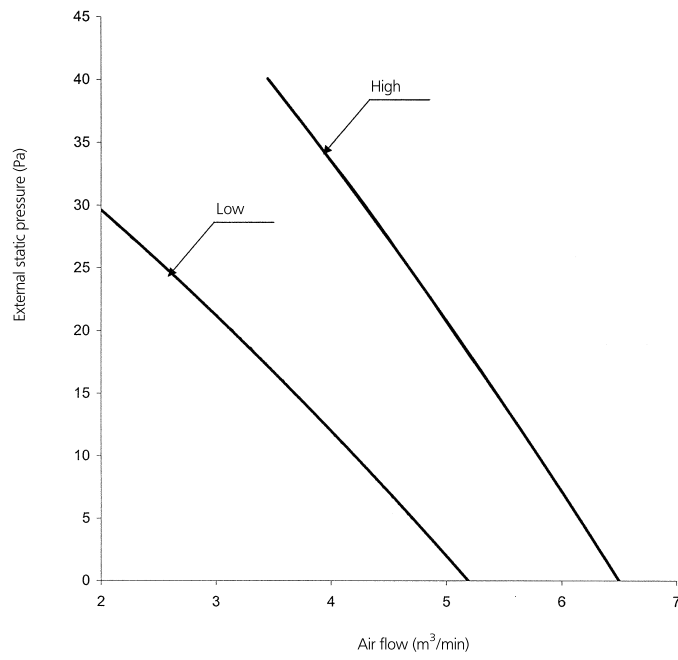

Note: The wired remote control can be used to switch between 'high' and 'low'

4TW25858-1

9 Installation

9 - 1 Installation Method

9

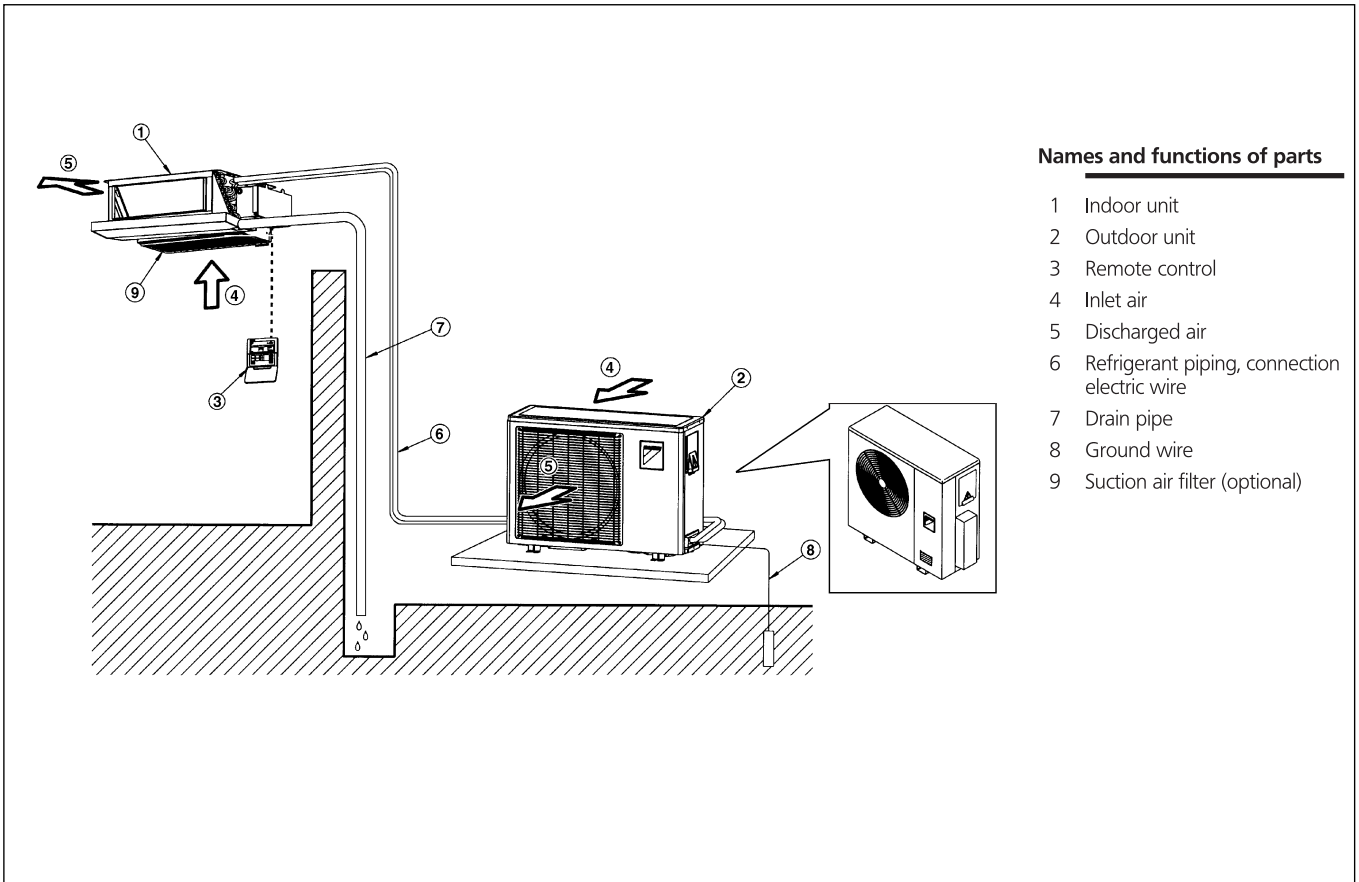

Daikin Europe N.V. Naamloze Vennootschap - Zandvoordestraat 300, B-8400 Oostende - Belgium - www.daikin.eu - BE 0412 120 336 - RPR Oostende

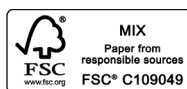
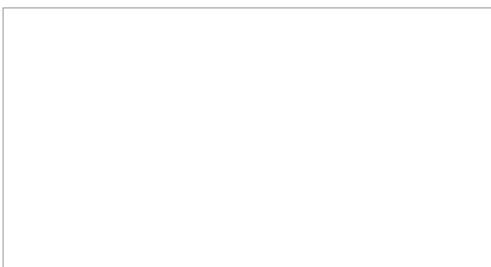

EEDEN17 02/17



Daikin Europe N.V. participates in the Eurovent Certification programme for Liquid Chilling Packages (LCP), Air handling units (AHU), Fan coil units (FCU) and variable refrigerant flow systems (VRF) Check ongoing validity of certificate online: www.eurovent-certification.com or using: www.certiflash.com



The present leaflet is drawn up by way of information only and does not constitute an offer binding upon Daikin Europe N.V.. Daikin Europe N.V. has compiled the content of this leaflet to the best of its knowledge. No express or implied warranty is given for the completeness, accuracy, reliability or fitness for particular purpose of its content and the products and services presented therein. Specifications are subject to change without prior notice. Daikin Europe N.V. explicitly rejects any liability for any direct or indirect damage, in the broadest sense, arising from or related to the use and/or interpretation of this leaflet. All content is copyrighted by Daikin Europe N.V.