



technical data



RR-B7

**Pair/Twin/Triple/Double Twin
Application**

air conditioning systems

Split Sky Air

Split - Sky Air



ISO14001 assures an effective environmental management system in order to help protect human health and the environment from the potential impact of our activities, products and services and to assist in maintaining and improving the quality of the environment



Daikin units comply with the European regulations that guarantee the safety of the product.



Daikin Europe N.V. is approved by LRQA for its Quality Management System in accordance with the ISO9001 standard. ISO9001 pertains to quality assurance regarding design, development, manufacturing as well as to services related to the product.



Daikin Europe N.V. participates in the Eurovent Certification Programme for Air Conditioners (AC), Liquid Chilling Packages (LCP) and Fan Coil Units (FC); the certified data of certified models are listed in the Eurovent Directory.

Specifications are subject to change without prior notice.

DAIKIN EUROPE N.V.

Zandvoordestraat 300
B - 8400 Ostend Belgium
www.daikineurope.com

TABLE OF CONTENTS

RR-B7

1	Features	2
2	Specifications	3
	Technical Specifications	3
	Electrical Specifications	5
	Electrical data	6
	Safety device settings	9
3	Options	10
4	Capacity tables	11
	Combination table	11
	Cooling capacity tables	12
	Cooling capacity tables simultaneous operation	18
5	Dimensional drawing & centre of gravity	19
	Dimensional drawing	19
	Centre of gravity	21
6	Piping diagram	23
7	Wiring diagram	25
	Wiring diagram	25
	External connection diagram	27
8	Sound data	28
	Sound pressure spectrum	28
	Sound power spectrum	29
9	Operation range	30

1 Features

1

- Outdoor units for pair, twin, triple, double twin application
- Daikin outdoor units are neat and sturdy and can be mounted easily on a roof or terrace or simply placed against an outside wall.
- Outdoor units are fitted with a scroll compressor, renowned for low noise and high energy efficiency.
- The piping connections can be accessed from underneath, front, side or rear.
- The service valves are hidden inside the casing.
- A special acryl precoated fin for anti-corrosion treatment on the heat exchanger ensures greater resistance against severe weather conditions



2 Specifications

2-1 TECHNICAL SPECIFICATIONS				RR71B7V3B	RR71B7W1B	RR100B7V3B	RR100B7W1B	RR125B7W1B	
Casing	Colour			Daikin White					
	Material			Painted galvanized steel plate					
Dimensions	Packing	Height	mm	900	900	1300	1300	1300	
		Width	mm	980	980	980	980	980	
		Depth	mm	420	420	420	420	420	
	Unit	Height	mm	770	770	1170	1170	1170	
		Width	mm	900	900	900	900	900	
		Depth	mm	320	320	320	320	320	
Weight	Machine Weight		kg	83	81	102	99	106	
	Gross Weight		kg	87	85	107	104	111	
Heat Exchanger	Dimensions	Length	mm	857	857	857	857	857	
		Nr of Rows			2	2	2	2	2
		Fin Pitch	mm	2.00	2.00	2.00	2.00	2.00	
		Nr of Passes			6	6	10	10	10
		Face Area	m ³	0.641	0.641	0.980	0.980	0.980	
		Nr of Stages			34	34	52	52	52
	Tube type		Hi-XSS cooling tube						
	Fin	Type	Non-symmetric waffle louvre						
		Treatment	Anti-corrosion treatment (PE)						
	Fan	Type			Direct Drive Propeller				
Discharge direction			Horizontal						
Quantity			1	1	1	1	2		
Air Flow Rate (nominal)		Cooling	m ³ /min	48.0	48.0	55.0	55.0	89.0	
Motor		Quantity		1	1	1	1	1	
		Model		P47L11S					
	Position						Lower		
Motor	Speed (nominal at 230V)	Steps	3	3	3	3	3		
Fan	Motor	Output	W	65	65	65	65	85	
		Drive			direct drive				
	Position						Upper		
Motor	Speed (nominal at 230V)	Steps					3		
Fan	Motor	Output	W					65	
		Drive						direct drive	
Compressor	Quantity			1	1	1	1	1	
	Motor	Model		JT90G-V1N	JT90G-YE	JT125G-V1N	JT125G-YE	JT160G-YE	
		Type			Hermetically sealed scroll compressor				
		Motor Output	W	2200	2200	3000	3000	3750	
		Starting Method			Direct				
	Crankcase Heater	W	33	33	33	33	33		
Operation Range	Cooling	Min	°CDB	-15.0	-15.0	-15.0	-15.0	-15.0	
		Max	°CDB	46.0	46.0	46.0	46.0	46.0	
Sound Level (nominal)	Cooling	Sound Power	dBA	63.0	63.0	66.0	66.0	67.0	
		Sound Pressure	dBA	50.0	50.0	53.0	53.0	53.0	
Refrigerant	Type			R-410A					
	Charge	kg		2.70	2.70	3.70	3.70	3.70	
	Control			Expansion valve (electronic type)					
	Nr of Circuits			1	1	1	1	1	
Refrigerant Oil	Type			Daphne FVC68D					
	Charged Volume		l	1.5	1.5	1.5	1.5	1.5	

2-1 TECHNICAL SPECIFICATIONS			RR71B7V3B	RR71B7W1B	RR100B7V3B	RR100B7W1B	RR125B7W1B
Piping connections	Liquid (OD)	Quantity	1	1	1	1	1
		Type	Flare connection				
		Diameter (OD) mm	9.52	9.52	9.52	9.52	9.52
	Gas	Quantity	1	1	1	1	1
		Type	Flare connection				
		Diameter (OD) mm	15.9	15.9	15.9	15.9	15.9
	Drain	Quantity	3	3	3	3	3
		Type	Hole				
		Diameter (OD) mm	26	26	26	26	26
	Piping Length	Minimum	m	5	5	5	5
		Maximum	m	70	70	70	70
		Equivalent	m	90	90	90	90
		Chargeless	m	30	30	30	30
	Installation height difference	Maximum	m	30.0	30.0	30.0	30.0
		Max. internunit level difference	m	0.5	0.5	0.5	0.5
Heat Insulation		Both liquid and gas pipes					
Defrost Method		Reversed cycle					
Defrost Control		Sensor for outdoor heat exchanger temperature					
Capacity Control Method		None					
Safety Devices		Reverse phase protector					
		PC board fuse					
		Overcurrent relay (compressor)					
		Low pressure switch					
		High pressure switch					
		Fan motor thermal protector					
Standard Accessories	Item		Declaration of conformity				
	Quantity		1	1	1	1	1
	Item		Installation manual				
Quantity		1	1	1	1	1	

2 Specifications

2-2 ELECTRICAL SPECIFICATIONS			RR71B7V3B	RR71B7W1B	RR100B7V3B	RR100B7W1B	RR125B7W1B
Power Supply	Name		V3	W1	V3	W1	W1
	Phase		1	3N	1	3N	3N
	Frequency	Hz	50	50	50	50	50
	Voltage	V	230	400	230	400	400
Current	Recommended fuses	A	32	16	40	16	20
Voltage range	Minimum	V	207	360	207	360	360
	Maximum	V	253	440	253	440	440
Wiring connections	For Power Supply	Quantity	1	1	1	1	1
		Remark	3 wires (earth wire included)	5 wires (earth wire included)	3 wires (earth wire included)	5 wires (earth wire included)	5 wires (earth wire included)
	For connection with indoor	Quantity	1	1	1	1	1
		Remark	4 wires (earth wire included)				
Power Supply Intake			Outdoor unit only				

NOTES

- 1 Sound pressure level is a relative value, depending on the distance and acoustic environment. For more details, please refer to sound level drawings of this chapter.
- 2 The sound power level is an absolute value indicating the power which a sound source generates.
- 3 Sound values are measured in a semi-anechoic room.
- 4 Heating capacity is only applicable for combination with heat pump outdoor unit.
- 5 In case of drain piping for outdoor unit, drain piping kit (option) is needed.
- 6 Nominal cooling capacities are based on : indoor temperature : 27°CDB, 19°CWB, outdoor temperature : 35°CDB, equivalent refrigerant piping : 7.5m, level difference : 0m.
- 7 Nominal heating capacities are based on : indoor temperature : 20°CDB, outdoor temperature : 7°CDB, 6°CWB, equivalent refrigerant piping : 7.5m, level difference : 0m.

2 Specifications

2 - 3 Electrical data

2 Electrical data

Unit combination		Power supply					Comp.		OFM		IFM	
Indoor unit	Outdoor unit	Hz-volts	Voltage range	MCA	TOCA	MFA	MSC	RLA	kW	FLA	kW	FLA
FCQ71	RR71B7V3B	50-230	Max. 50Hz-264V Min. 50Hz-198V	16.6	23.3	32	75.5	12.2	0.065	0.6	0.045	0.7
FUQ71	RR71B7V3B	50-230		16.6	23.2	32	75.5	12.3	0.065	0.6	0.045	0.6
FHQ71	RR71B7V3B	50-230		16.8	23.2	32	75.5	12.5	0.065	0.6	0.062	0.6
FAQ71	RR71B7V3B	50-230		16.1	22.9	32	75.5	12.2	0.065	0.6	0.043	0.3
FBQ71	RR71B7V3B	50-230		17.4	23.5	32	75.5	12.7	0.065	0.6	0.125	0.9
FCQ71	RR71B7W1B	50-400/230	Max. 50Hz-440/253V Min. 50Hz-360/197V	7.4	11.3	16	41.1	4.8	0.065	0.6	0.045	0.7
FUQ71	RR71B7W1B	50-400/230		7.3	11.2	16	41.1	4.9	0.065	0.6	0.045	0.6
FHQ71	RR71B7W1B	50-400/230		7.5	11.2	16	41.1	5.0	0.065	0.6	0.062	0.6
FAQ71	RR71B7W1B	50-400/230		6.8	10.9	16	41.1	4.7	0.065	0.6	0.043	0.3
FBQ71	RR71B7W1B	50-400/230		8.1	11.5	16	41.1	5.3	0.065	0.6	0.125	0.9

SYMBOLS

MCA	: Min. Circuit Amps
TOCA	: Total Over Current Amps
MFA	: Max. Fuse Amps (See note 7)
LRA	: Locked Rotor Amps
RLA	: Rated Load Amps
OFM	: Outdoor Fan Motor
IFM	: Indoor Fan Motor
FLA	: Full Load Amps
kW	: Fan Motor Rated Output

NOTES

- 1 RLA is based on the following conditions:
Indoor temperature 27°CDB/19.5°CWB
Outdoor temperature 35°CDB
- 2 TOCA means the total value of each OC set
- 3 Voltage range
Units are suitable for use on electrical systems where voltage supplied to unit terminals is not below or above listed operation range limits
- 4 Maximum allowable voltage unbalance between phases is 2%
- 5 MCA/MFA
 $MCA = 1.25 \times RLA + \text{all FLA}$
 $MFA \leq 2.25 \times RLA + \text{all FLA}$
(next lower standard fuse rating, min. 16A)
- 6 Select wire size based on the larger value of MCA or TOCA
- 7 Instead of fuse, use circuit breaker
- 8 For more details concerning conditional connections, see <http://www.daikineurope.com/extranet>, select "Daikin Documentation" and select "conditional connection", "the requested product type" and "English" from the drop down lists, click the search button.
Finally, click on the document title of your choice.

3TW26379-9A

2 Specifications

2 - 3 Electrical data

Electrical data

Unit combination		Power supply					Compressor		OFM		IFM			
Indoor unit	Outdoor unit	Hz-Volts	Voltage range			MCA	TOCA	MFA	LRA	RLA	kW	FLA	kW	FLA
FCQ100	RR100B7V3B	50-230	Max. 50Hz - 264V Min. 50Hz - 198V	23.8	34.8	40	98.5	17.6	0.090	0.8	0.090	1.0		
FUQ100	RR100B7V3B	50-230		23.3	34.8	40	98.5	17.2	0.090	0.8	0.090	1.0		
FHQ100	RR100B7V3B	50-230		23.0	34.5	40	98.5	17.2	0.090	0.8	0.130	0.7		
FAQ100	RR100B7V3B	50-230		23.0	34.2	40	98.5	17.4	0.090	0.8	0.049	0.4		
FBQ100	RR100B7V3B	50-230		23.2	34.8	40	98.5	17.1	0.090	0.8	0.135	1.0		
FCQ100	RR100B7W1B	50-400/230	Max. 50Hz - 440/253V Min. 50Hz - 360/197V	9.2	11.8	16	48.2	5.9	0.090	0.8	0.090	1.0		
FUQ100	RR100B7W1B	50-400/230		8.9	11.8	16	48.2	5.7	0.090	0.8	0.090	1.0		
FHQ100	RR100B7W1B	50-400/230		8.6	11.5	16	48.2	5.7	0.090	0.8	0.130	0.7		
FAQ100	RR100B7W1B	50-400/230		8.3	11.2	16	48.2	5.7	0.090	0.8	0.049	0.4		
FBQ100	RR100B7W1B	50-400/230		8.9	11.8	16	48.2	5.7	0.090	0.8	0.135	1.0		

SYMBOLS

MCA: Min. Circuit Amps
 TOCA: Total Over-current Amps
 MFA: Max. Fuse Amps (see note 7)
 LRA: Locked rotor Amps
 RLA: Rated Load Amps
 OFM: Outdoor Fan Motor
 IFM: Indoor Fan Motor
 FLA: Full Load Amps
 KW: Fan Motor Rated Output

NOTES

- 1 RLA based on the following conditions:
 Indoor temp. 27°CDB/19.5°CWB
 Outdoor temp. 35°CDB
- 2 TOCA means the total value of each OC set.
- 3 Voltage range: units are suitable for use on electrical systems where the voltage supplied to the unit terminals is not below or above the listed range limits.
- 4 Maximum allowable voltage unbalance between phases is 2%.
- 5 MCA/MFA
 $MCA = 1.25 \times RLA + \text{all FLA}$
 $MFA \leq 2.25 \times RLA + \text{all FLA}$
 (next lower standard fuse rating Min. 16A)
- 6 Select wire size based on the larger value of MCA or TOCA.
- 7 Instead of fuse, use circuit breaker.
- 8 For more details concerning conditional connections, see <http://www.daikineurope.com/extranet>, select "Daikin Documentation" and select "conditional connection", "the requested product type" and "English" from the drop down lists, click the search button. Finally, click on the document title of your choice.

3TW26399-9

2 Specifications

2 - 3 Electrical data

2

Electrical data

Unit combination		Power supply					Compressor		OFM		IFM	
Indoor unit	Outdoor unit	Hz-Volts	Voltage range	MCA	TOCA	MFA	LRA	RLA	kW	FLA	kW	FLA
FCQ125	RR125B7W1B	50-400/230	Max. 50Hz - 440/253V Min. 50Hz - 360/197V	11.9	15.3	20	63	7.7	0.065 + 0.085	0.6 + 0.7	0.09	1.0
FUQ125	RR125B7W1B	50-400/230		11.7	15.3	20	63	7.5	0.065 + 0.085	0.6 + 0.7	0.09	1.0
FHQ125	RR125B7W1B	50-400/230		11.4	15.0	20	63	7.5	0.065 + 0.085	0.6 + 0.7	0.13	0.7
FBQ125	RR125B7W1B	50-400/230		12.2	15.7	20	63	7.6	0.065 + 0.085	0.6 + 0.7	0.225	1.4
FDQ125	RR125B7W1B	50-400/230		14.9	18.5	20	63	7.5	0.065 + 0.085	0.6 + 0.7	0.5	4.2

SYMBOLS

MCA: Min. Circuit Amps
 TOCA: Total Over-current Amps
 MFA: Max. Fuse Amps (see note 7)
 LRA: Locked rotor Amps
 RLA: Rated Load Amps
 OFM: Outdoor Fan Motor
 IFM: Indoor Fan Motor
 FLA: Full Load Amps
 KW: Fan Motor Rated Output

NOTES

- 1 RLA based on the following conditions:
 Indoor temp. 27°CDB/19.5°CWB
 Outdoor temp. 35°CDB
- 2 TOCA means the total value of each OC set.
- 3 Voltage range: units are suitable for use on electrical systems where the voltage supplied to the unit terminals is not below or above the listed range limits.
- 4 Maximum allowable voltage unbalance between phases is 2%.
- 5 MCA/MFA
 $MCA = 1.25 \times RLA + \text{all FLA}$
 $MFA \leq 2.25 \times RLA + \text{all FLA}$
 (next lower standard fuse rating Min. 16A)
- 6 Select wire size based on the larger value of MCA or TOCA.
- 7 Instead of fuse, use circuit breaker.
- 8 For more details concerning conditional connections, see <http://www.daikineurope.com/extranet>, select "Daikin Documentation" and select "conditional connection", "the requested product type" and "English" from the drop down lists, click the search button. Finally, click on the document title of your choice.

3TW26419-9

2 Specifications

2 - 4 Safety device settings

R(Q)(R)71-125B7

2

Safety device Model	RQ71B7V3B	RQ100B7V3B		RR71B7V3B	RR100B7V3B	
	RQ71B7W1B	RQ100B7W1B	RQ125B7W1B	RR71B7W1B	RR100B7W1B	RR125B7W1B
Fan motor thermal protector	Off $135 \pm 5^{\circ}\text{C}$					
	On $95 \pm 15^{\circ}\text{C}$					
HPS	Off $4.15 +0 / -0.10 \text{ Mpa}$					
	On $3.2 +0.15 / -0.15 \text{ Mpa}$					
LPS	Off $0.03 +0.02 / -0.02 \text{ Mpa}$					
	On $0.05 +0.03 / -0.03 \text{ Mpa}$					
Max discharge temperature	By thermistor and software control					
Overcurrent relay	By overcurrent sensor and software control					

4TW26321-2B

3 Options

3

Available option for RQ71-125B7(V3,W1)B and RR71-125B7(V3,W1)B

Name of option		Kit name					
		RQ71B7	RQ100B7	RQ125B7	RR71B7	RR100B7	RR125B7
Central drain plug		KKPJ5F180					
Refrigerant branch piping	Twin	KHRQ22M20TA7					
	Triple	-	KHRQ127H7	-	KHRQ127H7		

3TW26329-1

4 Capacity tables

4 - 1 Combination table

Possible combinations and standard capacity for twin and triple operation

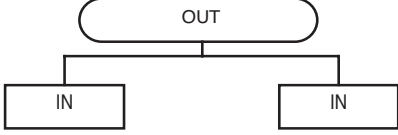
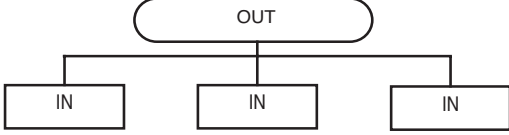
Outdoor models	Possible indoor combination						
	Simultaneous operation						
	Twin			Triple			
							
RQ71B7V3/W1 RR71B7V3/W1	35-35 (KHRQ22M20TA7)						
RQ100B7V3/W1 RR100B7V3/W1	50-50 (KHRQ22M20TA7)	50-60 (KHRQ22M20TA7)	35-71 (KHRQ22M20TA7)	35-35-35 (KHRQ127H7)			
RQ125B7W1 RR125B7W1	60-60 (KHRQ22M20TA7)	50-71 (KHRQ22M20TA7)		50-50-50 (KHRQ127H7)			

- Possible indoor types:
FCQ 35-71
FFQ 35-60
FUQ 71
FHQ 35-71
FAQ 71
FBQ 35-71
- Individual indoor capacities are not given because the combinations are for simultaneous operation (= indoor units installed in same room).
- When different indoor models are used in combination, designate the remote controller that is equipped with the most functions as the main unit.
- Between brackets are the required Refnet kits mentioned, that are necessary to install the combination.
- For unit specification of the outdoor units and the indoor units refer to the unit specifications mentioned for pair systems.
- Nominal cooling capacities are based on the following conditions: indoor air temperature: 27°CDB, 19°CWB, outdoor temperature: 35°CDB.
Nominal heating capacities are based on the following conditions: indoor air temperature: 20°CDB, outdoor temperature 7°CDB, 6°CWB.

4 Capacity tables

4 - 2 Cooling capacity tables

4

FAQ71-100BUV1B + RR71-100B7V3B / RR71-100B7W1B

Cooling capacity

Outdoor	Indoor		Outdoor temperature (°CDB)																	
	EWB (°C)	EDB (°C)	20			25			32			35			40			46		
			TC	SHC	PI	TC	SHC	PI	TC	SHC	PI	TC	SHC	PI	TC	SHC	PI	TC	SHC	PI
71	12.0	18.0	6.2	4.9	1.81	6.1	4.8	1.97	5.7	4.7	2.20	5.5	4.6	2.36	5.3	4.5	2.60	4.8	4.1	2.83
	14.0	20.0	6.6	4.9	1.84	6.5	4.8	2.00	6.0	4.7	2.24	5.9	4.6	2.40	5.5	4.5	2.64	5.2	4.1	2.88
	16.0	22.0	7.2	5.0	1.88	7.0	4.9	2.04	6.5	4.8	2.28	6.3	4.7	2.45	6.0	4.6	2.69	5.4	4.2	2.93
	18.0	25.0	7.7	5.2	1.92	7.5	5.0	2.09	7.2	4.9	2.34	6.8	4.8	2.50	6.4	4.6	2.76	5.9	4.4	3.01
	19.0	27.0	8.0	5.3	1.94	7.7	5.2	2.11	7.3	5.0	2.36	7.1	4.8	2.53	6.6	4.7	2.78	6.1	4.5	3.04
	19.5	27.0	8.0	5.3	1.95	7.9	5.2	2.12	7.4	5.0	2.37	7.2	4.8	2.54	6.7	4.7	2.79	6.2	4.5	3.05
	22.0	30.0	8.7	5.4	1.98	8.5	5.3	2.16	8.0	5.2	2.42	7.9	4.9	2.59	7.4	4.8	2.85	6.7	4.5	3.11
24.0	32.0	9.4	5.4	2.00	9.1	5.3	2.18	8.6	5.2	2.44	8.4	5.0	2.61	8.0	4.8	2.88	7.3	4.5	3.14	
100	12.0	18.0	8.4	7.2	2.49	8.3	7.1	2.75	8.1	6.9	3.11	7.8	6.8	3.29	7.5	6.4	3.64	6.8	6.1	4.08
	14.0	20.0	8.9	7.2	2.53	8.8	7.1	2.80	8.7	6.9	3.16	8.4	6.8	3.34	7.8	6.4	3.71	7.4	6.1	4.16
	16.0	22.0	10.1	7.3	2.57	9.8	7.2	2.85	9.1	7.0	3.22	8.9	6.9	3.40	8.5	6.5	3.77	7.7	6.2	4.23
	18.0	25.0	10.8	7.6	2.64	10.5	7.5	2.92	9.8	7.1	3.30	9.6	7.0	3.48	9.0	6.8	3.86	8.3	6.3	4.33
	19.0	27.0	11.1	7.7	2.66	10.8	7.6	2.95	10.1	7.2	3.33	10.0	7.1	3.52	9.4	6.9	3.90	8.6	6.4	4.38
	19.5	27.0	11.2	7.7	2.67	11.0	7.6	2.96	10.3	7.2	3.34	10.1	7.1	3.53	9.5	6.9	3.91	8.7	6.4	4.39
	22.0	30.0	12.2	7.8	2.73	11.8	7.7	3.02	11.2	7.3	3.41	11.0	7.2	3.60	10.4	7.1	3.99	9.5	6.7	4.48
24.0	32.0	13.0	7.9	2.75	12.7	7.8	3.05	11.9	7.5	3.44	11.6	7.3	3.64	11.1	7.2	4.03	10.2	6.8	4.52	

SYMBOLS

FR: Air flow rate [m3/min.]
 BF: Bypass factor
 EWB: Entering wet bulb temp. [°CWB]
 EDB: Entering dry bulb temp. [°CDB]
 DB*: Dry bulb temp. [°CDB]
 TC: Total capacity cooling [kW]
 SHC: Sensible heat capacity [kW]
 PI: Power input (Comp. + indoor + outdoor fan motor) [kW]

CAUTION

TC and SHC are given in kW.
 V1/V3: 230V [50 Hz]
 W1: 400V [50Hz]

NOTES

- Ratings shown are net capacities. Influence on fan motor heat is included.
- | |
|--|
| |
|--|

 shows nominal capacities.
- SHC is based on each EWB and EDB.
 SHC* = SHC correction for other dry bulb.

$$= 0.29 \times 60 \times \text{AFR} [\text{m}^3/\text{min.}] \times (1-\text{BF}) \times (\text{DB}^*-\text{EDB})/860$$
 Add SHC* to SHC if SHC > TC, then TC = SHC.
- Direct interpolation is permissible. Do not extrapolate.
- Capacities are based on the following conditions.
 Corresponding refrigerant piping length: 7.5m
 Level difference: 0m
- Air flow rate and BF are tabulated below.

Model		FAQ
71	AFR	19
	BF	0.08
100	AFR	23
	BF	0.1

- Add the following corrections to power input of each model.

Model		FAQ
71	V3	0.12
	W1	0
100	V3	0.04
	W1	0

3TW26372-5

4 Capacity tables

4 - 2 Cooling capacity tables

FUQ71-125BUV1B + RR71-100B7V3B / RR71-125B7W1B

Cooling capacity table

Outdoor	Indoor		Outdoor temp. (°CDB)																	
	EWB (°C)	EDB (°C)	20			25			32			35			40			46		
			TC	SHC	PI	TC	SHC	PI	TC	SHC	PI	TC	SHC	PI	TC	SHC	PI	TC	SHC	PI
71	12.0	18.0	6.2	4.9	1.90	6.1	4.8	2.06	5.7	4.7	2.31	5.5	4.6	2.47	5.3	4.5	2.72	4.8	4.1	2.97
	14.0	20.0	6.6	4.9	1.93	6.5	4.8	2.10	6.0	4.7	2.35	5.9	4.6	2.52	5.5	4.5	2.77	5.2	4.1	3.02
	16.0	22.0	7.2	5.0	1.96	7.0	4.9	2.13	6.5	4.8	2.39	6.3	4.7	2.56	6.0	4.6	2.82	5.4	4.2	3.07
	18.0	25.0	7.7	5.2	2.01	7.5	5.0	2.19	7.2	4.9	2.45	6.8	4.8	2.62	6.4	4.6	2.89	5.9	4.4	3.15
	19.0	27.0	8.0	5.3	2.03	7.7	5.2	2.21	7.3	5.0	2.47	7.1	4.8	2.65	6.6	4.7	2.92	6.1	4.5	3.18
	19.5	27.0	8.0	5.3	2.04	7.9	5.2	2.22	7.4	5.0	2.48	7.2	4.8	2.66	6.7	4.7	2.92	6.2	4.5	3.19
	22.0	30.0	8.7	5.4	2.08	8.5	5.3	2.26	8.0	5.2	2.53	7.9	4.9	2.71	7.4	4.8	2.98	6.7	4.5	3.25
24.0	32.0	9.4	5.4	2.10	9.1	5.3	2.28	8.6	5.2	2.56	8.4	5.0	2.74	8.0	4.8	3.01	7.3	4.5	3.29	
100	12.0	18.0	8.4	7.2	2.67	8.3	7.1	2.96	8.1	6.9	3.34	7.8	6.8	3.53	7.5	6.4	3.91	6.8	6.1	4.39
	14.0	20.0	8.9	7.2	2.72	8.8	7.1	3.01	8.7	6.9	3.40	8.4	6.8	3.59	7.8	6.4	3.98	7.4	6.1	4.46
	16.0	22.0	10.1	7.3	2.77	9.8	7.2	3.06	9.1	7.0	3.46	8.9	6.9	3.65	8.5	6.5	4.05	7.7	6.2	4.54
	18.0	25.0	10.8	7.6	2.83	10.5	7.5	3.14	9.8	7.1	3.54	9.6	7.0	3.74	9.0	6.8	4.15	8.3	6.3	4.65
	19.0	27.0	11.1	7.7	2.86	10.8	7.6	3.17	10.1	7.2	3.58	10.0	7.1	3.78	9.4	6.9	4.19	8.6	6.4	4.70
	19.5	27.0	11.2	7.7	2.87	11.0	7.6	3.18	10.3	7.2	3.59	10.1	7.1	3.79	9.5	6.9	4.20	8.7	6.4	4.72
	22.0	30.0	12.2	7.8	2.93	11.8	7.7	3.24	11.2	7.3	3.66	11.0	7.2	3.87	10.4	7.1	4.29	9.5	6.7	4.81
24.0	32.0	13.0	7.9	2.96	12.7	7.8	3.27	11.9	7.5	3.69	11.6	7.3	3.91	11.1	7.2	4.33	10.2	6.8	4.86	
125	12.0	18.0	11.1	9.5	3.43	10.8	9.2	3.62	10.0	8.7	3.98	9.7	8.6	4.27	9.2	8.4	4.73	8.5	7.9	5.19
	14.0	20.0	11.8	9.5	3.49	11.4	9.2	3.68	10.7	8.7	4.06	10.4	8.6	4.34	9.8	8.4	4.82	9.1	7.9	5.28
	16.0	22.0	12.7	9.6	3.56	12.1	9.3	3.75	11.4	8.8	4.13	11.1	8.7	4.42	10.4	8.5	4.90	9.6	8.0	5.38
	18.0	25.0	13.3	9.9	3.64	13.0	9.5	3.84	12.1	9.1	4.23	11.8	9.0	4.52	11.2	8.7	5.02	10.3	8.3	5.51
	19.0	27.0	13.6	10.0	3.68	13.3	9.5	3.88	12.7	9.2	4.27	12.2	9.0	4.57	11.5	8.8	5.07	10.7	8.4	5.56
	19.5	27.0	13.8	10.0	3.69	13.5	9.5	3.89	12.8	9.2	4.28	12.4	9.1	4.59	11.7	8.8	5.09	10.9	8.4	5.58
	22.0	30.0	15.1	10.1	3.76	14.6	9.8	3.97	13.7	9.4	4.37	13.4	9.3	4.68	12.9	9.1	5.19	11.9	8.6	5.69
24.0	32.0	15.9	10.2	3.80	15.5	9.9	4.01	14.6	9.5	4.41	14.3	9.4	4.72	13.6	9.2	5.24	12.8	8.9	5.75	

3TW26372-4A

SYMBOLS

AFR:	Air flow rate	(m ³ /min)
BF:	Bypass factor	
EWB:	Entering wet bulb temp.	(°CWB)
EDB:	Entering dry bulb temp.	(°CDB)
DB*:	Dry bulb temp.	(°CDB)
TC:	Total cooling/heating capacity	(kW)
SHC:	Sensible heating capacity	(kW)
PI:	Power input	(kW)
	(comp.+indoor+outdoor fan motor)	

Caution:

TC and SHC are shown by kW
 V1/V3: 230 V [50 Hz]
 W1: 400 V [50 Hz]

NOTES

- Ratings shown are net capacities. Influence of fan motor heat is included.
- Shows nominal capacities
- SHC is based on each EWB and EDB
 $SHC^* = SHC \text{ correction for other dry bulb}$
 $SHC^* = 0.29 \times 60 \times AFR \text{ (m}^3\text{/min.)} \times (1-BF) \times (DB^*-EDB)/860$
 Add SHC* to SHC if SHC > TC, then TC equal SHC
- Direct interpolation is permissible. Do not extrapolate.
- Capacities are based on following conditions:
 Corresponding refrigerant piping length : 7.5 m
 Level difference : 0 m
- Air flow rate and BF are tabulated below.

Model		FUQ
71	AFR	19
	BF	0.07
100	AFR	29
	BF	0.07
125	AFR	45
	BF	0.25

- Add the following corrections to power input of each model.

Model	Supply	FUQ
71	V3	0.05
	W1	0
100	V3	0.05
	W1	0
125	W1	0

4 Capacity tables

4 - 2 Cooling capacity tables

4

FBQ71-125B7V3B + RR71-100B7V3B / RR71-125B7W1B

Cooling capacity table

Outdoor	Indoor		Outdoor temp. (°CDB)																	
	EWB	EDB	20			25			32			35			40			46		
	(°C)	(°C)	TC	SHC	PI	TC	SHC	PI	TC	SHC	PI	TC	SHC	PI	TC	SHC	PI	TC	SHC	PI
71	12.0	18.0	6.2	4.8	1.92	6.1	4.7	2.08	5.7	4.6	2.33	5.5	4.5	2.50	5.3	4.4	2.75	4.8	4.0	3.00
	14.0	20.0	6.6	4.8	1.95	6.5	4.7	2.12	6.0	4.6	2.38	5.9	4.5	2.55	5.5	4.4	2.80	5.2	4.0	3.06
	16.0	22.0	7.2	4.9	1.99	7.0	4.8	2.16	6.5	4.7	2.42	6.3	4.6	2.59	6.0	4.5	2.85	5.4	4.1	3.11
	18.0	25.0	7.7	5.1	2.03	7.5	4.9	2.21	7.2	4.8	2.48	6.8	4.7	2.65	6.4	4.5	2.92	5.9	4.3	3.18
	19.0	27.0	8.0	5.2	2.05	7.7	5.1	2.23	7.3	4.9	2.50	7.1	4.7	2.68	6.6	4.6	2.95	6.1	4.4	3.22
	19.5	27.0	8.0	5.2	2.06	7.9	5.1	2.24	7.4	4.9	2.51	7.2	4.7	2.69	6.7	4.6	2.96	6.2	4.4	3.23
	22.0	30.0	8.7	5.3	2.10	8.5	5.2	2.29	8.0	5.1	2.56	7.9	4.8	2.74	7.4	4.7	3.02	6.7	4.4	3.29
	24.0	32.0	9.4	5.3	2.12	9.1	5.2	2.31	8.6	5.1	2.58	8.4	4.9	2.77	8.0	4.7	3.05	7.3	4.4	3.32
100	12.0	18.0	8.4	7.0	2.54	8.3	6.9	2.82	8.1	6.7	3.18	7.8	6.6	3.36	7.5	6.2	3.72	6.8	5.9	4.18
	14.0	20.0	8.9	7.0	2.59	8.8	6.9	2.87	8.7	6.7	3.24	8.4	6.6	3.42	7.8	6.2	3.79	7.4	5.9	4.25
	16.0	22.0	10.1	7.1	2.63	9.8	7.0	2.92	9.1	6.8	3.29	8.9	6.7	3.48	8.5	6.3	3.86	7.7	6.0	4.33
	18.0	25.0	10.8	7.4	2.70	10.5	7.3	2.99	9.8	6.9	3.37	9.6	6.8	3.56	9.0	6.6	3.95	8.3	6.1	4.43
	19.0	27.0	11.1	7.5	2.72	10.8	7.4	3.02	10.1	7.0	3.41	10.0	6.9	3.60	9.4	6.7	3.99	8.6	6.2	4.48
	19.5	27.0	11.2	7.5	2.73	11.0	7.4	3.03	10.3	7.0	3.42	10.1	6.9	3.61	9.5	6.7	4.00	8.7	6.2	4.49
	22.0	30.0	12.2	7.6	2.79	11.8	7.5	3.09	11.2	7.1	3.48	11.0	7.0	3.68	10.4	6.9	4.08	9.5	6.5	4.58
	24.0	32.0	13.0	7.7	2.82	12.7	7.6	3.12	11.9	7.3	3.52	11.6	7.1	3.72	11.1	7.0	4.12	10.2	6.6	4.62
125	12.0	18.0	11.1	9.1	3.51	10.8	8.8	3.70	10.0	8.3	4.07	9.7	8.2	4.36	9.2	8.0	4.84	8.5	7.5	5.30
	14.0	20.0	11.8	9.1	3.57	11.4	8.8	3.77	10.7	8.3	4.14	10.4	8.2	4.44	9.8	8.0	4.92	9.1	7.5	5.40
	16.0	22.0	12.7	9.2	3.63	12.1	8.9	3.83	11.4	8.4	4.22	11.1	8.3	4.51	10.4	8.1	5.01	9.6	7.6	5.49
	18.0	25.0	13.3	9.5	3.72	13.0	9.1	3.92	12.1	8.7	4.32	11.8	8.6	4.62	11.2	8.3	5.13	10.3	7.9	5.63
	19.0	27.0	13.6	9.6	3.76	13.3	9.1	3.96	12.7	8.8	4.36	12.2	8.6	4.67	11.5	8.4	5.18	10.7	8.0	5.68
	19.5	27.0	13.8	9.6	3.77	13.5	9.1	3.98	12.8	8.8	4.38	12.4	8.7	4.69	11.7	8.4	5.20	10.9	8.0	5.70
	22.0	30.0	15.1	9.7	3.85	14.6	9.4	4.06	13.7	9.0	4.46	13.4	8.9	4.78	12.9	8.7	5.30	11.9	8.2	5.82
	24.0	32.0	15.9	9.8	3.88	15.5	9.5	4.10	14.6	9.1	4.51	14.3	9.0	4.83	13.6	8.8	5.35	12.8	8.5	5.87

3TW26372-2A

SYMBOLS

AFR:	Air flow rate	(m ³ /min)
BF:	Bypass factor	
EWB:	Entering wet bulb temp.	(°CWB)
EDB:	Entering dry bulb temp.	(°CDB)
DB*:	Dry bulb temp.	(°CDB)
TC:	Total cooling/heating capacity	(kW)
SHC:	Sensible heating capacity	(kW)
PI:	Power input	(kW)
	(comp.+indoor+outdoor fan motor)	

Caution:

TC and SHC are shown by kW
 V3: 230 V [50 Hz]
 W1: 400 V [50 Hz]

NOTES

- Ratings shown are net capacities. Influence of fan motor heat is included.
- Shows nominal capacities
- SHC is based on each EWB and EDB
 $SHC^* = SHC$ correction for other dry bulb
 $SHC^* = 0.29 \times 60 \times AFR (m^3/min.) \times (1-BF) \times (DB^*-EDB)/860$
 Add SHC* to SHC if SHC > TC, then TC equal SHC
- Direct interpolation is permissible. Do not extrapolate.
- Capacities are based on following conditions:
 Corresponding refrigerant piping length : 7.5 m
 Level difference : 0 m
- Air flow rate and BF are tabulated below.

Model		FBQ
71	AFR	19
	BF	0.11
100	AFR	27
	BF	0.2
125	AFR	35
	BF	0.14

- Add the following corrections to power input of each model.

Model	Supply	FBQ
71	V3	0.11
	W1	0
100	V3	0.19
	W1	0
125	W1	0

4 Capacity tables

4 - 2 Cooling capacity tables

FCQ71-125B7V3B + RR71-100B7V3B / RR71-100B7W1B

Cooling capacity

Outdoor	Indoor		Outdoor temperature (°CDB)																	
	EWB (°C)	EDB (°C)	20			25			32			35			40			46		
			TC	SHC	PI	TC	SHC	PI	TC	SHC	PI	TC	SHC	PI	TC	SHC	PI	TC	SHC	PI
71	12,0	18,0	6,2	4,8	1,90	6,1	4,7	2,07	5,7	4,6	2,32	5,5	4,5	2,48	5,3	4,4	2,73	4,8	4,0	2,98
	14,0	20,0	6,6	4,8	1,94	6,5	4,7	2,11	6,0	4,6	2,36	5,9	4,5	2,53	5,5	4,4	2,78	5,2	4,0	3,03
	16,0	22,0	7,2	4,9	1,97	7,0	4,8	2,14	6,5	4,7	2,40	6,3	4,6	2,57	6,0	4,5	2,83	5,4	4,1	3,09
	18,0	25,0	7,7	5,1	2,02	7,5	4,9	2,19	7,2	4,8	2,46	6,8	4,7	2,63	6,4	4,5	2,90	5,9	4,3	3,16
	19,0	27,0	8,0	5,2	2,04	7,7	5,1	2,22	7,3	4,9	2,48	7,1	4,7	2,66	6,6	4,6	2,93	6,1	4,4	3,19
	19,5	27,0	8,0	5,2	2,05	7,9	5,1	2,22	7,4	4,9	2,49	7,2	4,7	2,67	6,7	4,6	2,94	6,2	4,4	3,20
	22,0	30,0	8,7	5,3	2,09	8,5	5,2	2,27	8,0	5,1	2,54	7,9	4,8	2,72	7,4	4,7	2,99	6,7	4,4	3,27
	24,0	32,0	9,4	5,3	2,11	9,1	5,2	2,29	8,6	5,1	2,57	8,4	4,9	2,75	8,0	4,7	3,02	7,3	4,4	3,30
100	12,0	18,0	8,4	7,0	2,51	8,3	6,9	2,78	8,1	6,7	3,14	7,8	6,6	3,32	7,5	6,2	3,68	6,8	5,9	4,13
	14,0	20,0	8,9	7,0	2,56	8,8	6,9	2,83	8,7	6,7	3,20	8,4	6,6	3,38	7,8	6,2	3,75	7,4	5,9	4,20
	16,0	22,0	10,1	7,1	2,60	9,8	7,0	2,88	9,1	6,8	3,26	8,9	6,7	3,44	8,5	6,3	3,81	7,7	6,0	4,28
	18,0	25,0	10,8	7,4	2,67	10,5	7,3	2,95	9,8	6,9	3,33	9,6	6,8	3,52	9,0	6,6	3,91	8,3	6,1	4,38
	19,0	27,0	11,1	7,5	2,69	10,8	7,4	2,98	10,1	7,0	3,37	10,0	6,9	3,56	9,4	6,7	3,94	8,6	6,2	4,43
	19,5	27,0	11,2	7,5	2,70	11,0	7,4	2,99	10,3	7,0	3,38	10,1	6,9	3,57	9,5	6,7	3,96	8,7	6,2	4,44
	22,0	30,0	12,2	7,6	2,76	11,8	7,5	3,05	11,2	7,1	3,45	11,0	7,0	3,64	10,4	6,9	4,04	9,5	6,5	4,53
	24,0	32,0	13,0	7,7	2,78	12,7	7,6	3,08	11,9	7,3	3,48	11,6	7,1	3,68	11,1	7,0	4,08	10,2	6,6	4,57
125	12,0	18,0	11,4	9,3	3,50	11,1	9,0	3,69	10,3	8,5	4,06	10,0	8,4	4,35	9,5	8,2	4,83	8,8	7,7	5,29
	14,0	20,0	12,1	9,3	3,56	11,7	9,0	3,76	11,0	8,5	4,14	10,7	8,4	4,43	10,1	8,2	4,91	9,4	7,7	5,39
	16,0	22,0	13,0	9,4	3,63	12,4	9,1	3,82	11,7	8,6	4,21	11,4	8,5	4,50	10,7	8,3	5,00	9,9	7,8	5,48
	18,0	25,0	13,6	9,7	3,71	13,3	9,3	3,92	12,4	8,9	4,31	12,1	8,8	4,61	11,5	8,5	5,12	10,6	8,1	5,61
	19,0	27,0	13,9	9,8	3,75	13,6	9,3	3,95	13,0	9,0	4,35	12,5	8,8	4,66	11,8	8,6	5,17	11,0	8,2	5,67
	19,5	27,0	14,1	9,8	3,76	13,8	9,3	3,97	13,1	9,0	4,37	12,7	8,9	4,68	12,0	8,6	5,19	11,2	8,2	5,69
	22,0	30,0	15,4	9,9	3,84	14,9	9,6	4,05	14,0	9,2	4,46	13,7	9,1	4,77	13,2	8,9	5,29	12,2	8,4	5,80
	24,0	32,0	16,2	10,0	3,88	15,8	9,7	4,09	14,9	9,3	4,50	14,6	9,2	4,82	13,9	9,0	5,34	13,1	8,7	5,86

SYMBOLS

FR: Air flow rate [m3/min.]
 BF: Bypass factor
 EWB: Entering wet bulb temp. [°CWB]
 EDB: Entering dry bulb temp. [°CDB]
 DB*: Dry bulb temp. [°CDB]
 TC: Total capacity cooling [kW]
 SHC: Sensible heat capacity [kW]
 PI: Power input (Comp. + indoor + outdoor fan motor) [kW]

CAUTION

TC and SHC are given in kW.
 V1/V3: 230V [50 Hz]
 W1: 400V [50Hz]

NOTES

- Ratings shown are net capacities. Influence on fan motor heat is included.
- shows nominal capacities.
- SHC is based on each EWB and EDB.
 $SHC^* = SHC \text{ correction for other dry bulb.}$
 $= 0,29 \times 60 \times AFR [m3/min.] \times (1-BF) \times (DB^*-EDB)/860$
 Add SHC* to SHC if SHC > TC, then TC = SHC.
- Direct interpolation is permissible. Do not extrapolate.
- Capacities are based on the following conditions.
 Corresponding refrigerant piping length: 7,5m
 Level difference: 0m
- Air flow rate and BF are tabulated below.

Model		FCQ
71	AFR	18
	BF	0,1
100	AFR	28
	BF	0,16
125	AFR	32
	BF	0,07

- Add the following corrections to power input of each model.

Model		FCQ
71	V3	0,06
	W1	0
100	V3	0,27
	W1	0
125	W1	0

3TW26372-1

4 Capacity tables

4 - 2 Cooling capacity tables

4

FHQ71-125BUV1B + RR71-100B7V3B / RR71-100B7W1B

Cooling capacity

Outdoor	Indoor		Outdoor temperature (°CDB)																	
	EWB (°C)	EDB (°C)	20			25			32			35			40			46		
			TC	SHC	PI	TC	SHC	PI	TC	SHC	PI	TC	SHC	PI	TC	SHC	PI	TC	SHC	PI
71	12,0	18,0	6,2	4,8	1,90	6,1	4,7	2,06	5,7	4,6	2,31	5,5	4,5	2,47	5,3	4,4	2,72	4,8	4,0	2,97
	14,0	20,0	6,6	4,8	1,93	6,5	4,7	2,10	6,0	4,6	2,35	5,9	4,5	2,52	5,5	4,4	2,77	5,2	4,0	3,02
	16,0	22,0	7,2	4,9	1,96	7,0	4,8	2,13	6,5	4,7	2,39	6,3	4,6	2,56	6,0	4,5	2,82	5,4	4,1	3,07
	18,0	25,0	7,7	5,1	2,01	7,5	4,9	2,19	7,2	4,8	2,45	6,8	4,7	2,62	6,4	4,5	2,89	5,9	4,3	3,15
	19,0	27,0	8,0	5,2	2,03	7,7	5,1	2,21	7,3	4,9	2,47	7,1	4,7	2,65	6,6	4,6	2,92	6,1	4,4	3,18
	19,5	27,0	8,0	5,2	2,04	7,9	5,1	2,22	7,4	4,9	2,48	7,2	4,7	2,66	6,7	4,6	2,92	6,2	4,4	3,19
	22,0	30,0	8,7	5,3	2,08	8,5	5,2	2,26	8,0	5,1	2,53	7,9	4,8	2,71	7,4	4,7	2,98	6,7	4,4	3,25
24,0	32,0	9,4	5,3	2,10	9,1	5,2	2,28	8,6	5,1	2,56	8,4	4,9	2,74	8,0	4,7	3,01	7,3	4,4	3,29	
100	12,0	18,0	8,2	6,8	2,60	8,1	6,7	2,88	7,9	6,5	3,25	7,6	6,4	3,43	7,3	6,0	3,81	6,6	5,7	4,27
	14,0	20,0	8,7	6,8	2,65	8,6	6,7	2,93	8,5	6,5	3,31	8,2	6,4	3,50	7,6	6,0	3,87	7,2	5,7	4,35
	16,0	22,0	9,9	6,9	2,69	9,6	6,8	2,98	8,9	6,6	3,37	8,7	6,5	3,56	8,3	6,1	3,94	7,5	5,8	4,42
	18,0	25,0	10,6	7,2	2,76	10,3	7,1	3,05	9,6	6,7	3,45	9,4	6,6	3,64	8,8	6,4	4,04	8,1	5,9	4,53
	19,0	27,0	10,9	7,3	2,78	10,6	7,2	3,08	9,9	6,8	3,48	9,8	6,7	3,68	9,2	6,5	4,08	8,4	6,0	4,58
	19,5	27,0	11,0	7,3	2,79	10,8	7,2	3,09	10,1	6,8	3,49	9,9	6,7	3,69	9,3	6,5	4,09	8,5	6,0	4,59
	22,0	30,0	12,0	7,4	2,85	11,6	7,3	3,16	11,0	6,9	3,56	10,8	6,8	3,77	10,2	6,7	4,17	9,3	6,3	4,68
24,0	32,0	12,8	7,5	2,88	12,5	7,4	3,19	11,7	7,1	3,60	11,4	6,9	3,80	10,9	6,8	4,21	10,0	6,4	4,73	
125	12,0	18,0	11,1	9,1	3,39	10,8	8,8	3,57	10,0	8,3	3,93	9,7	8,2	4,21	9,2	8,0	4,67	8,5	7,5	5,12
	14,0	20,0	11,8	9,1	3,45	11,4	8,8	3,64	10,7	8,3	4,00	10,4	8,2	4,28	9,8	8,0	4,75	9,1	7,5	5,21
	16,0	22,0	12,7	9,2	3,51	12,1	8,9	3,70	11,4	8,4	4,07	11,1	8,3	4,36	10,4	8,1	4,84	9,6	7,6	5,31
	18,0	25,0	13,3	9,5	3,59	13,0	9,1	3,79	12,1	8,7	4,17	11,8	8,6	4,46	11,2	8,3	4,95	10,3	7,9	5,43
	19,0	27,0	13,6	9,6	3,63	13,3	9,1	3,83	12,7	8,8	4,21	12,2	8,6	4,51	11,5	8,4	5,00	10,7	8,0	5,49
	19,5	27,0	13,8	9,6	3,64	13,5	9,1	3,84	12,8	8,8	4,23	12,4	8,7	4,53	11,7	8,4	5,02	10,9	8,0	5,51
	22,0	30,0	15,1	9,7	3,71	14,6	9,4	3,92	13,7	9,0	4,31	13,4	8,9	4,62	12,9	8,7	5,12	11,9	8,2	5,62
24,0	32,0	15,9	9,8	3,75	15,5	9,5	3,96	14,6	9,1	4,35	14,3	9,0	4,66	13,6	8,8	5,17	12,8	8,5	5,67	

SYMBOLS

FR: Air flow rate [m3/min.]
 BF: Bypass factor
 EWB: Entering wet bulb temp. [°CWB]
 EDB: Entering dry bulb temp. [°CDB]
 DB*: Dry bulb temp. [°CDB]
 TC: Total capacity cooling [kW]
 SHC: Sensible heat capacity [kW]
 PI: Power input (Comp. + indoor + outdoor fan motor) [kW]

CAUTION

TC and SHC are given in kW.
 V1/V3: 230V [50 Hz]
 W1: 400V [50Hz]

NOTES

- Ratings shown are net capacities. Influence on fan motor heat is included.
- shows nominal capacities.
- SHC is based on each EWB and EDB.
 $SHC^* = SHC \text{ correction for other dry bulb.}$
 $= 0,29 \times 60 \times AFR [m3/min.] \times (1-BF) \times (DB^*-EDB)/860$
 Add SHC* to SHC if SHC > TC, then TC = SHC.
- Direct interpolation is permissible. Do not extrapolate.
- Capacities are based on the following conditions.
 Corresponding refrigerant piping length: 7,5m
 Level difference: 0m
- Air flow rate and BF are tabulated below.

Model		FHQ
71	AFR	17
	BF	0,1
100	AFR	24
	BF	0,14
125	AFR	30
	BF	0,13

- Add the following corrections to power input of each model.

Model		FHQ
71	V3	0,05
	W1	0
100	V3	0,07
	W1	0
125	W1	0

3TW26372-3

4 Capacity tables

4 - 2 Cooling capacity tables

FDQ71-125BUV1B + RR71-100B7V3B / RR71-100B7W1B

Cooling capacity

Outdoor	Indoor		Outdoor temperature (°CDB)																	
	EWB (°C)	EDB (°C)	20			25			32			35			40			46		
			TC	SHC	PI	TC	SHC	PI	TC	SHC	PI	TC	SHC	PI	TC	SHC	PI	TC	SHC	PI
125	12.0	18.0	11.4	10.7	3.60	11.1	10.4	3.79	10.3	9.9	4.18	10.0	9.8	4.47	9.5	9.6	4.96	8.8	9.1	5.44
	14.0	20.0	12.1	10.7	3.66	11.7	10.4	3.86	11.0	9.9	4.25	10.7	9.8	4.55	10.1	9.6	5.05	9.4	9.1	5.54
	16.0	22.0	13.0	10.8	3.73	12.4	10.5	3.93	11.7	10.0	4.33	11.4	9.9	4.63	10.7	9.7	5.14	9.9	9.2	5.64
	18.0	25.0	13.6	11.1	3.82	13.3	10.7	4.02	12.4	10.3	4.43	12.1	10.2	4.74	11.5	9.9	5.26	10.6	9.5	5.77
	19.0	27.0	13.9	11.2	3.86	13.6	10.7	4.07	13.0	10.4	4.47	12.5	10.2	4.79	11.8	10.0	5.32	11.0	9.6	5.83
	19.5	27.0	14.1	11.2	3.87	13.8	10.7	4.08	13.1	10.4	4.49	12.7	10.3	4.81	12.0	10.0	5.33	11.2	9.8	5.85
	22.0	30.0	15.4	11.3	3.95	14.9	11.0	4.16	14.0	10.6	4.58	13.7	10.5	4.90	13.2	10.3	5.44	12.2	9.8	5.97
	24.0	32.0	16.2	11.4	3.98	15.8	11.1	4.20	14.9	10.7	4.62	14.6	10.6	4.95	13.9	10.4	5.49	13.1	10.1	6.02

SYMBOLS

- FR: Air flow rate [m3/min.]
- BF: Bypass factor
- EWB: Entering wet bulb temp. [°CWB]
- EDB: Entering dry bulb temp. [°CDB]
- DB*: Dry bulb temp. [°CDB]
- TC: Total capacity cooling [kW]
- SHC: Sensible heat capacity [kW]
- PI: Power input (Comp. + indoor + outdoor fan motor) [kW]

CAUTION

- TC and SHC are given in kW.
- V1/V3: 230V [50 Hz]
- W1: 400V [50Hz]

NOTES

- 1 Ratings shown are net capacities. Influence on fan motor heat is included.
- 2 shows nominal capacities.
- 3 SHC is based on each EWB and EDB.
 $SHC^* = SHC \text{ correction for other dry bulb.}$
 $= 0.29 \times 60 \times AFR [m3/min.] \times (1-BF) \times (DB^*-EDB)/860$
 Add SHC* to SHC if SHC > TC, then TC = SHC.
- 4 Direct interpolation is permissible. Do not extrapolate.
- 5 Capacities are based on the following conditions.
 Corresponding refrigerant piping length: 7.5m
 Level difference: 0m
- 6 Air flow rate and BF are tabulated below.

Model		FDQ
125	AFR	45
	BF	0.25

3TW26372-6

4 Capacity tables

4 - 3 Cooling capacity tables simultaneous operation

4

Simultaneous operation RQ71-100-125B7 and RR71-100-125B7

Cooling capacity

Outdoor	Indoor		RQ												RR											
	EWB (°C)	EDB (°C)	Outdoor temperature (°CDB)												Outdoor temperature (°CDB)											
			20		25		32		35		40		46		20		25		32		35		40		46	
TC	PI	TC	PI	TC	PI	TC	PI	TC	PI	TC	PI	TC	PI	TC	PI	TC	PI	TC	PI	TC	PI	TC	PI	TC	PI	
71	12.0	18.0	6.2	1.80	6.1	1.95	5.7	2.19	5.5	2.34	5.3	2.58	4.9	2.81	6.2	1.80	6.1	1.95	5.7	2.19	5.5	2.34	5.3	2.58	4.9	2.81
	14.0	20.0	6.6	1.83	6.5	1.99	6.0	2.23	5.9	2.38	5.5	2.62	5.3	2.86	6.6	1.83	6.5	1.99	6.0	2.23	5.9	2.38	5.5	2.62	5.3	2.86
	16.0	22.0	7.2	1.86	7.0	2.02	6.5	2.26	6.3	2.43	6.0	2.67	5.5	2.91	7.2	1.86	7.0	2.02	6.5	2.26	6.3	2.43	6.0	2.67	5.5	2.91
	18.0	25.0	7.7	1.91	7.5	2.07	7.2	2.32	6.8	2.48	6.4	2.73	6.0	2.98	7.7	1.91	7.5	2.07	7.2	2.32	6.8	2.48	6.4	2.73	6.0	2.98
	19.0	27.0	8.0	1.92	7.7	2.09	7.3	2.34	7.1	2.51	6.6	2.76	6.2	3.01	8.0	1.92	7.7	2.09	7.3	2.34	7.1	2.51	6.6	2.76	6.2	3.01
	19.5	27.0	8.0	1.93	7.9	2.10	7.4	2.35	7.2	2.52	6.7	2.77	6.3	3.02	8.0	1.93	7.9	2.10	7.4	2.35	7.2	2.52	6.7	2.77	6.3	3.02
	22.0	30.0	8.7	1.97	8.5	2.14	8.0	2.40	7.9	2.57	7.4	2.83	6.8	3.08	8.7	1.97	8.5	2.14	8.0	2.40	7.9	2.57	7.4	2.83	6.8	3.08
24.0	32.0	9.4	1.99	9.1	2.16	8.6	2.42	8.4	2.59	8.0	2.85	7.4	3.11	9.4	1.99	9.1	2.16	8.6	2.42	8.4	2.59	8.0	2.85	7.4	3.11	
100	12.0	18.0	8.4	2.53	8.3	2.80	8.1	3.16	7.8	3.34	7.5	3.70	6.8	4.15	8.4	2.53	8.3	2.80	8.1	3.16	7.8	3.34	7.5	3.70	6.8	4.15
	14.0	20.0	8.9	2.57	8.8	2.85	8.7	3.22	8.4	3.40	7.8	3.77	7.4	4.23	8.9	2.57	8.8	2.85	8.7	3.22	8.4	3.40	7.8	3.77	7.4	4.23
	16.0	22.0	10.1	2.62	9.8	2.90	9.1	3.27	8.9	3.46	8.5	3.83	7.7	4.30	10.1	2.62	9.8	2.90	9.1	3.27	8.9	3.46	8.5	3.83	7.7	4.30
	18.0	25.0	10.8	2.68	10.5	2.97	9.8	3.35	9.6	3.54	9.0	3.93	8.3	4.41	10.8	2.68	10.5	2.97	9.8	3.35	9.6	3.54	9.0	3.93	8.3	4.41
	19.0	27.0	11.1	2.71	10.8	3.00	10.1	3.39	10.0	3.58	9.4	3.97	8.6	4.45	11.1	2.71	10.8	3.00	10.1	3.39	10.0	3.58	9.4	3.97	8.6	4.45
	19.5	27.0	11.2	2.72	11.0	3.01	10.3	3.40	10.1	3.59	9.5	3.98	8.7	4.47	11.2	2.72	11.0	3.01	10.3	3.40	10.1	3.59	9.5	3.98	8.7	4.47
	22.0	30.0	12.2	2.77	11.8	3.07	11.2	3.47	11.0	3.66	10.4	4.06	9.5	4.55	12.2	2.77	11.8	3.07	11.2	3.47	11.0	3.66	10.4	4.06	9.5	4.55
24.0	32.0	13.0	2.80	12.7	3.10	11.9	3.50	11.6	3.70	11.1	4.10	10.2	4.60	13.0	2.80	12.7	3.10	11.9	3.50	11.6	3.70	11.1	4.10	10.2	4.60	
125	12.0	18.0	11.1	3.37	10.8	3.55	10.0	3.91	9.7	4.18	9.2	4.64	8.5	5.09	11.1	3.37	10.8	3.55	10.0	3.91	9.7	4.18	9.2	4.64	8.5	5.09
	14.0	20.0	11.8	3.43	11.4	3.61	10.7	3.98	10.4	4.26	9.8	4.72	9.1	5.18	11.8	3.43	11.4	3.61	10.7	3.98	10.4	4.26	9.8	4.72	9.1	5.18
	16.0	22.0	12.7	3.49	12.1	3.68	11.4	4.05	11.1	4.33	10.4	4.81	9.6	5.27	12.7	3.49	12.1	3.68	11.4	4.05	11.1	4.33	10.4	4.81	9.6	5.27
	18.0	25.0	13.3	3.57	13.0	3.76	12.1	4.14	11.8	4.44	11.2	4.92	10.3	5.40	13.3	3.57	13.0	3.76	12.1	4.14	11.8	4.44	11.2	4.92	10.3	5.40
	19.0	27.0	13.6	3.61	13.3	3.80	12.7	4.19	12.2	4.48	11.5	4.97	10.7	5.45	13.6	3.61	13.3	3.80	12.7	4.19	12.2	4.48	11.5	4.97	10.7	5.45
	19.5	27.0	13.8	3.62	13.5	3.81	12.8	4.20	12.4	4.49	11.7	4.99	10.9	5.47	13.8	3.62	13.5	3.81	12.8	4.20	12.4	4.49	11.7	4.99	10.9	5.47
	22.0	30.0	15.1	3.69	14.6	3.89	13.7	4.28	13.4	4.58	12.9	5.09	11.9	5.58	15.1	3.69	14.6	3.89	13.7	4.28	13.4	4.58	12.9	5.09	11.9	5.58
24.0	32.0	15.9	3.73	15.5	3.93	14.6	4.32	14.3	4.63	13.6	5.14	12.8	5.63	15.9	3.73	15.5	3.93	14.6	4.32	14.3	4.63	13.6	5.14	12.8	5.63	

SYMBOLS

EWB: Entering wet bulb temp. [°CWB]
 EDB: Entering dry bulb temp. [°CDB]
 TC: Total capacity heating [kW]
 PI o: Power input of outdoor unit [kW]
 PI corr1: Correction factor for PI depending on voltage of outdoor [kW]
 PI corr2: Correction factor for PI depending used indoor units [kW]
 PI: Total power input [kW]
 $PI = PI o + PI corr1 + \sum PI corr2$
 e.g. RQ100B7V3B + FBQ71B7V3B + FHQ35B7V1B
 $PI = 3.58 + 0.27 + 0.21 + 0.14 = 4.2 \text{ kW}$

NOTES

- Ratings shown are net capacities which include a deduction for indoor fan motor heat.
- | |
|--|
| |
|--|

 shows nominal capacities.
- Capacities are based on the following conditions.
Corresponding refrigerant piping length: 7.5m
Level difference: 0m
- Direct interpolation is permissible. Do not extrapolate.
- Add the following correction to the power input for the different outdoor units (PI corr1).

Outdoor model	Power supply	
	V3	W1
RQ71	0.12	0
RQ100	0.27	0
RR71	0.12	0
RR100	0.27	0

- Add the following correction to the power input for each connected indoor unit (PI corr2).

Indoor model	Indoor types					
	FBQ	FHQ	FFQ	FCQ	FAQ	FUQ
35	0.12	0.14	0.08	0.14	-	-
50	0.16	0.14	0.09	0.14	-	-
60	0.21	0.14	0.11	0.16	-	-
71	0.21	0.14	-	0.16	0.069	0.16

- The total capacity does not change with different combination of indoor units.

5 Dimensional drawing & centre of gravity

5 - 1 Dimensional drawing

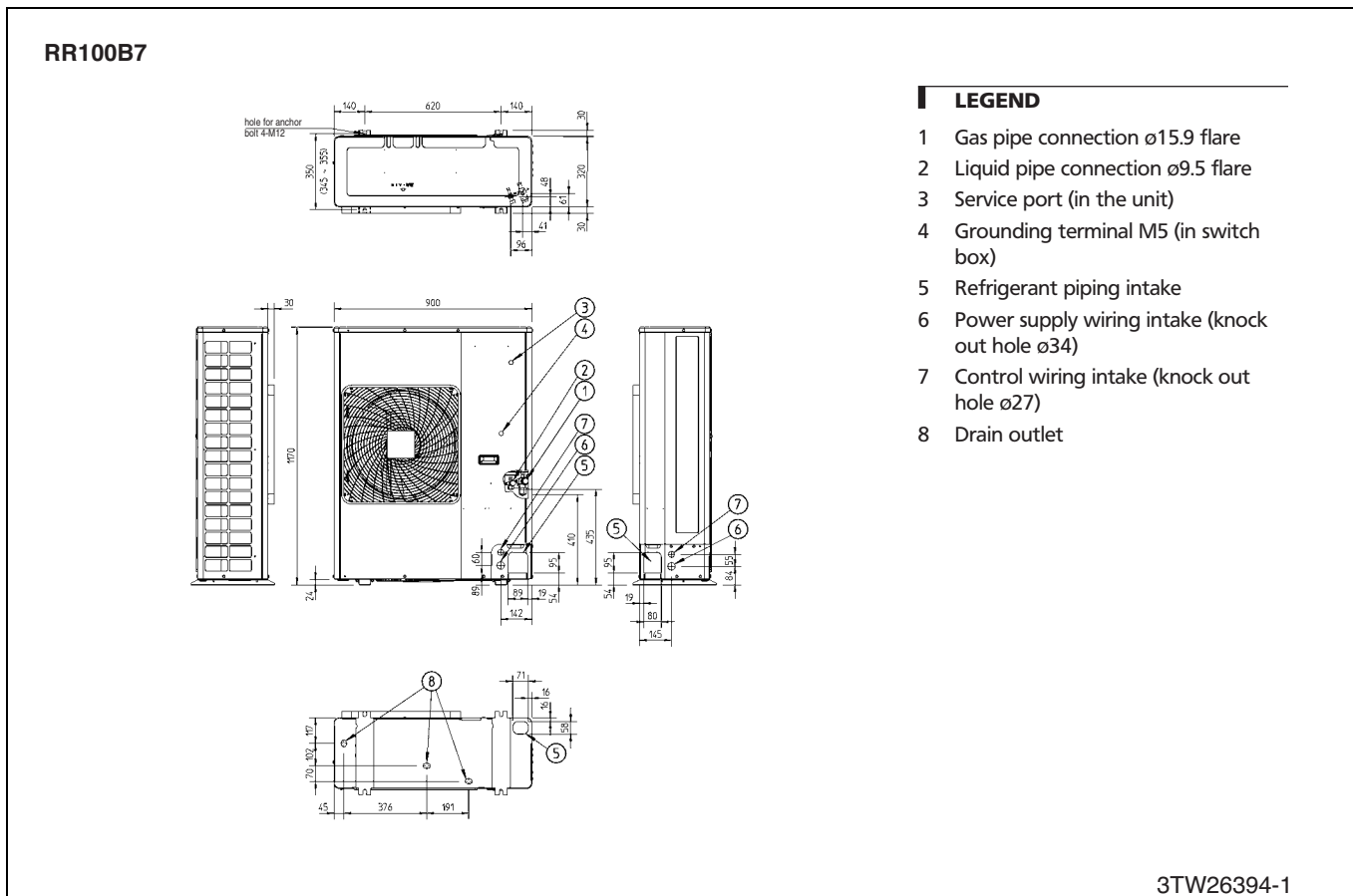
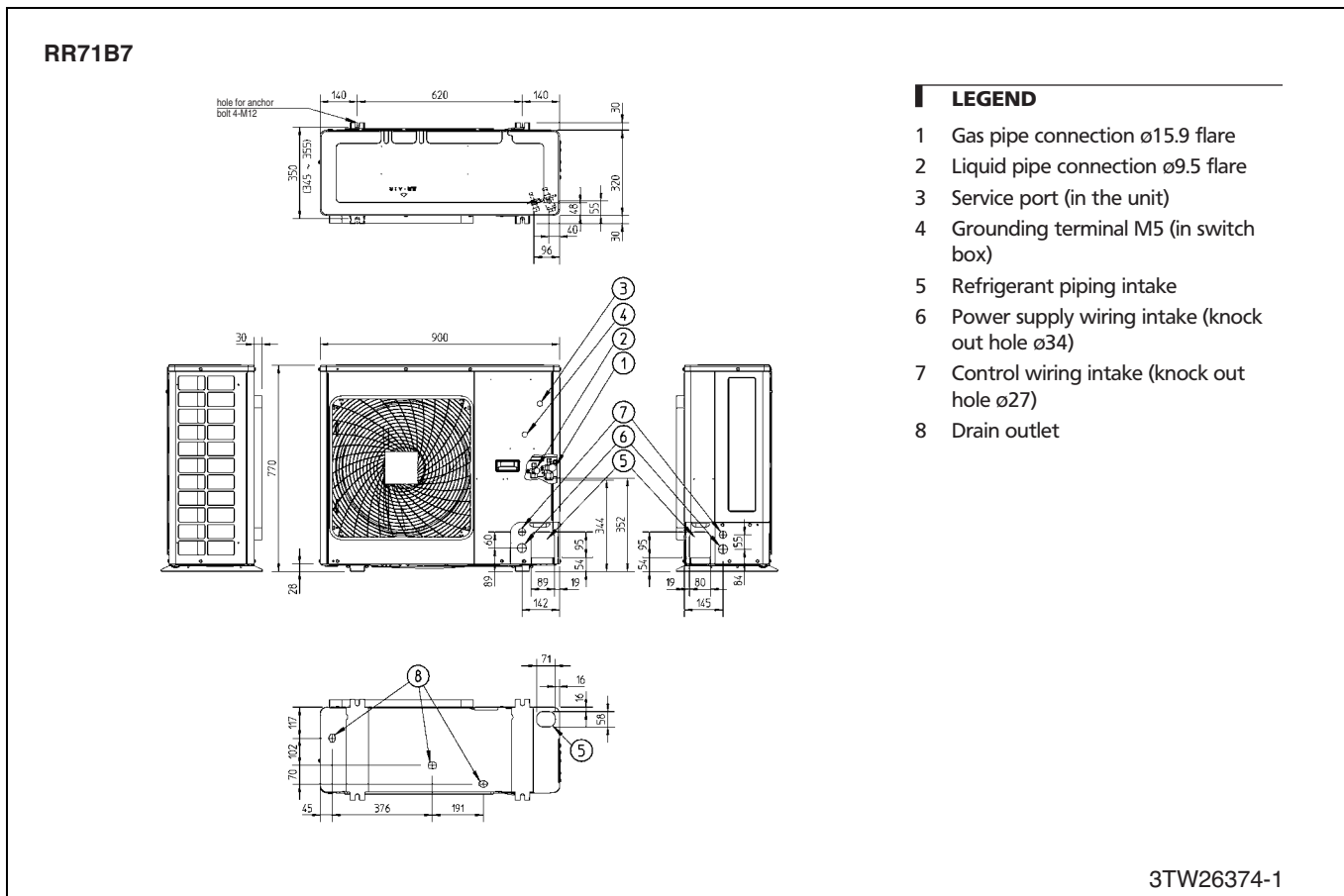

5 Dimensional drawing & centre of gravity

5 - 1 Dimensional drawing

5

RR125B7

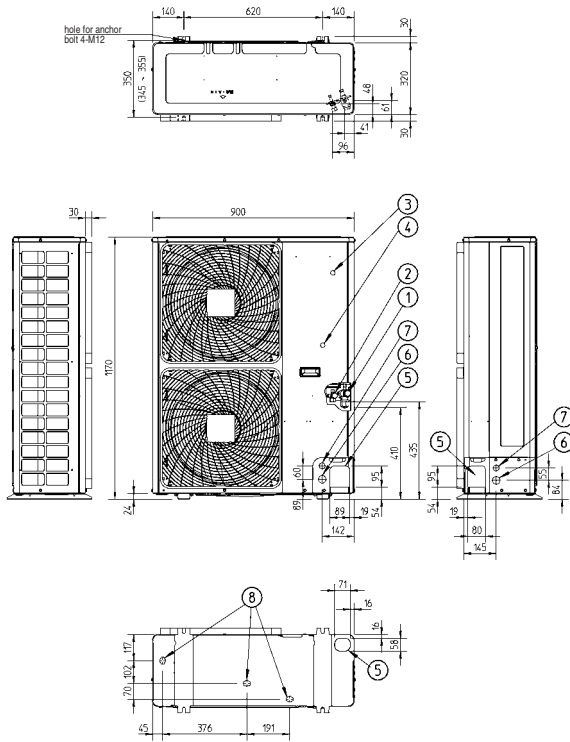

LEGEND

- 1 Gas pipe connection $\phi 15.9$ flare
- 2 Liquid pipe connection $\phi 9.5$ flare
- 3 Service port (in the unit)
- 4 Grounding terminal M5 (in switch box)
- 5 Refrigerant piping intake
- 6 Power supply wiring intake (knock out hole $\phi 34$)
- 7 Control wiring intake (knock out hole $\phi 27$)
- 8 Drain outlet

3TW26414-1

5 Dimensional drawing & centre of gravity

5 - 2 Centre of gravity

R(Q)(R)71B7

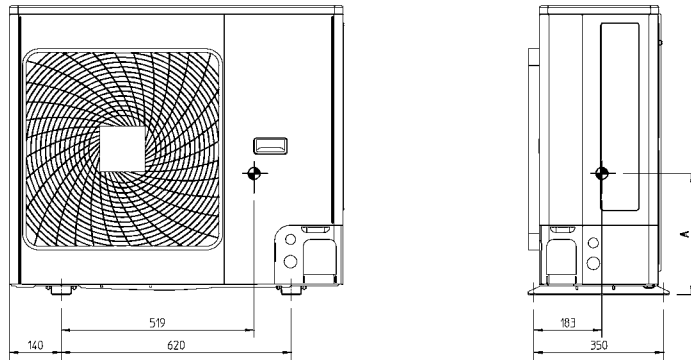

3TW26329-5B

R(Q)(R)100B7

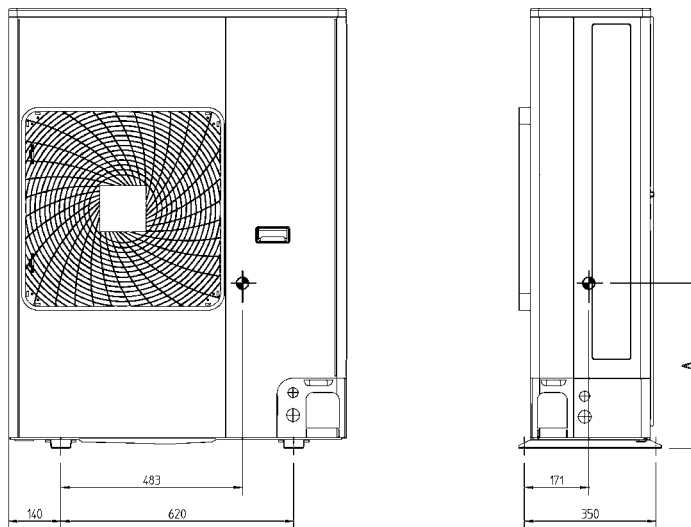

3TW26349-5B

5 Dimensional drawing & centre of gravity

5 - 2 Centre of gravity

5

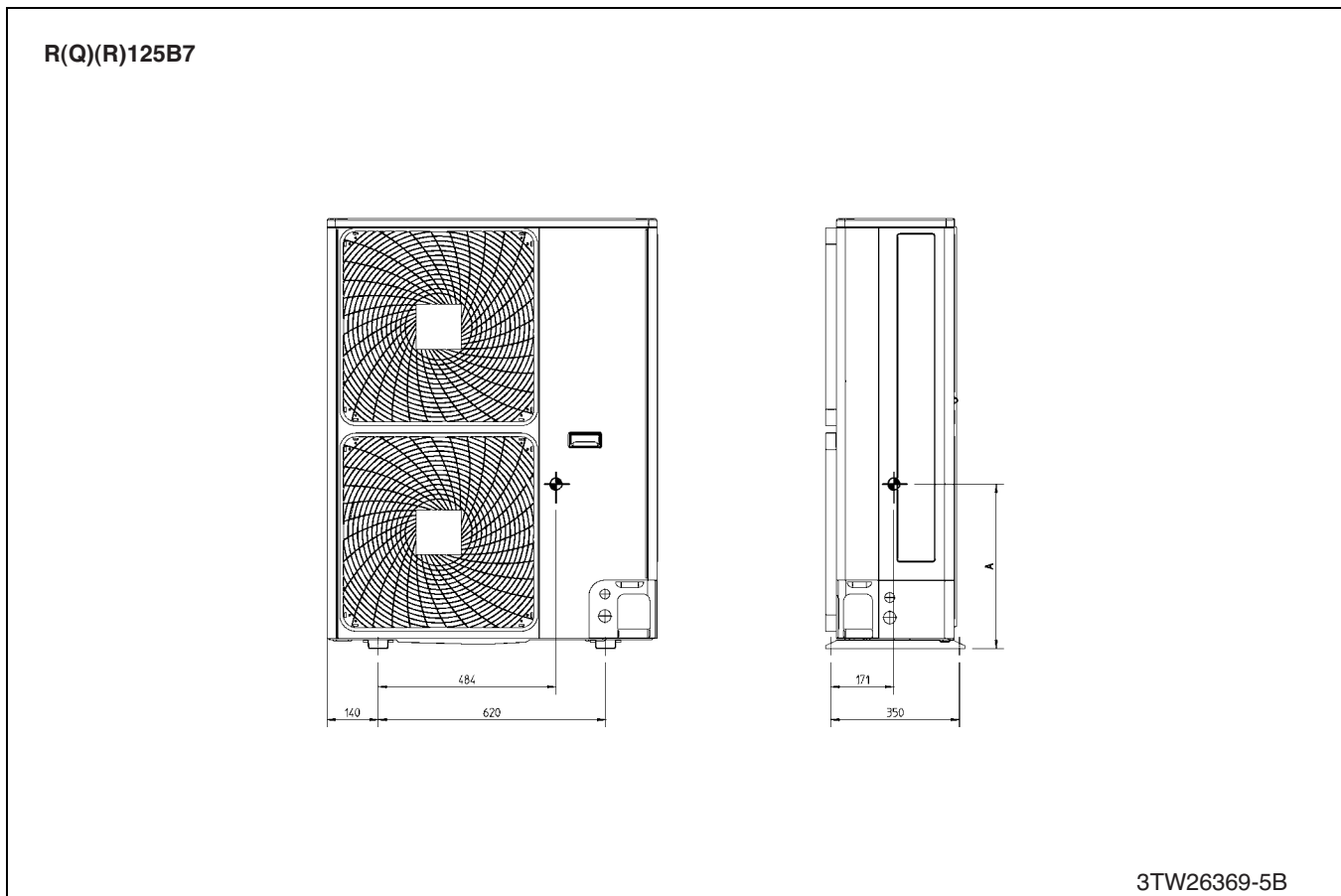

6 Piping diagram

RR71-125B7 (pair)

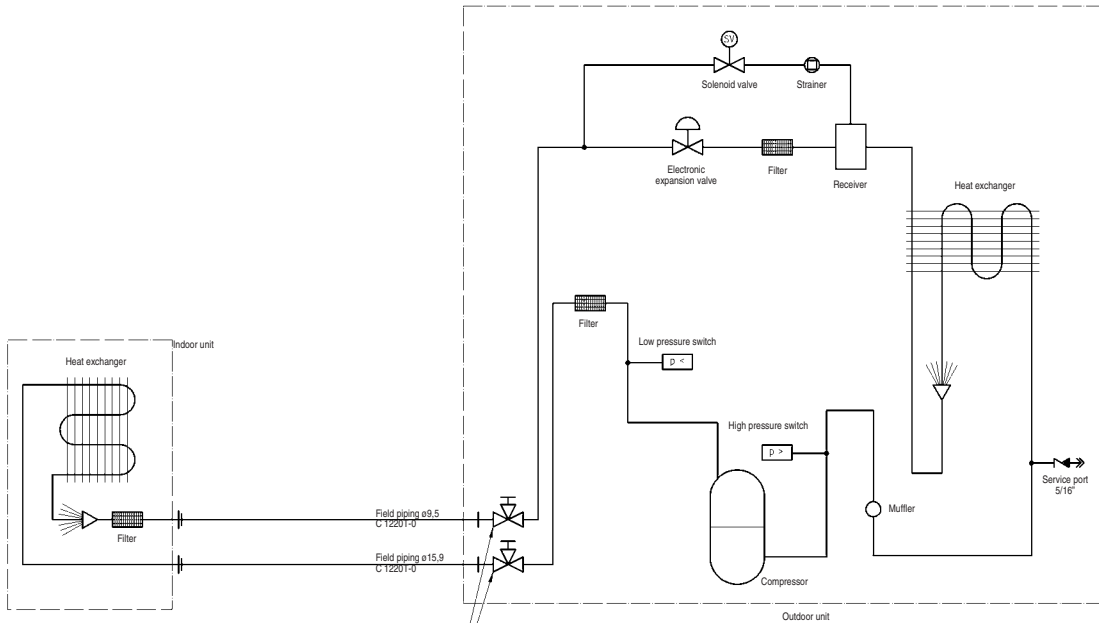

NOTE

- 1 The pipes between the branch and the indoor units should have the same size as the indoor connections.

Check valve
 Flexible connection
 Flare connection
 Screw connection
 Flange connection
 Pinched pipe
 Spinned pipe

3TW26375-1

RR71-125B7 (twin)

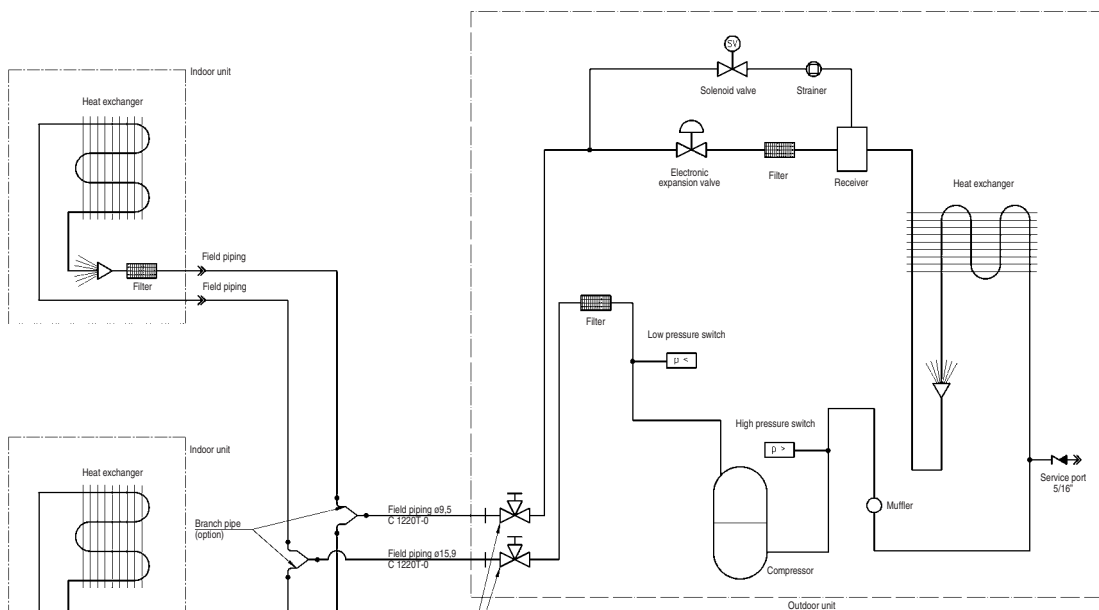

NOTE

- 1 The pipes between the branch and the indoor units should have the same size as the indoor connections.

Check valve
 Flexible connection
 Flare connection
 Screw connection
 Flange connection
 Pinched pipe
 Spinned pipe

3TW26375-2

6 Piping diagram

6

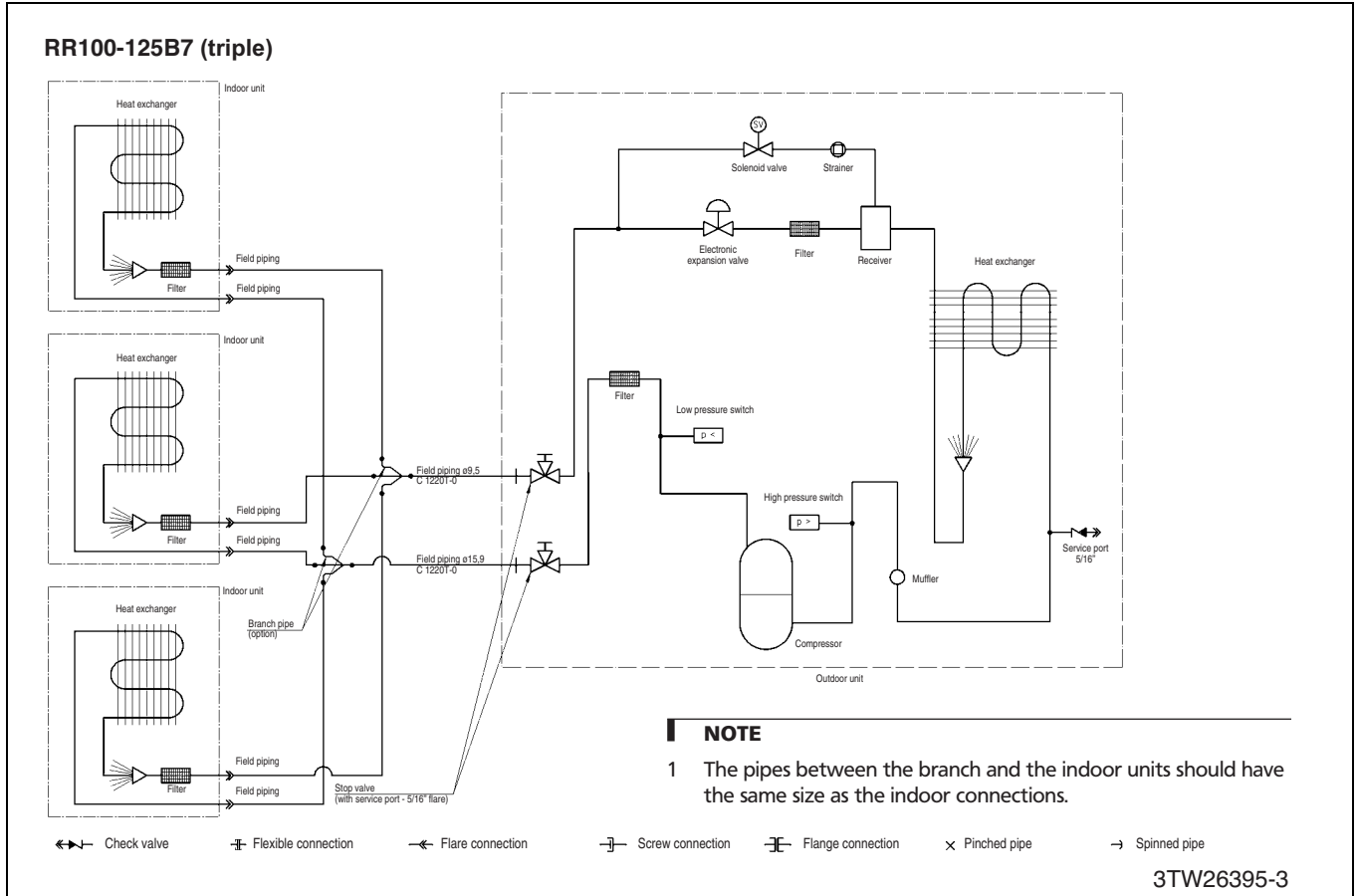

7 Wiring diagram

7 - 1 Wiring diagram

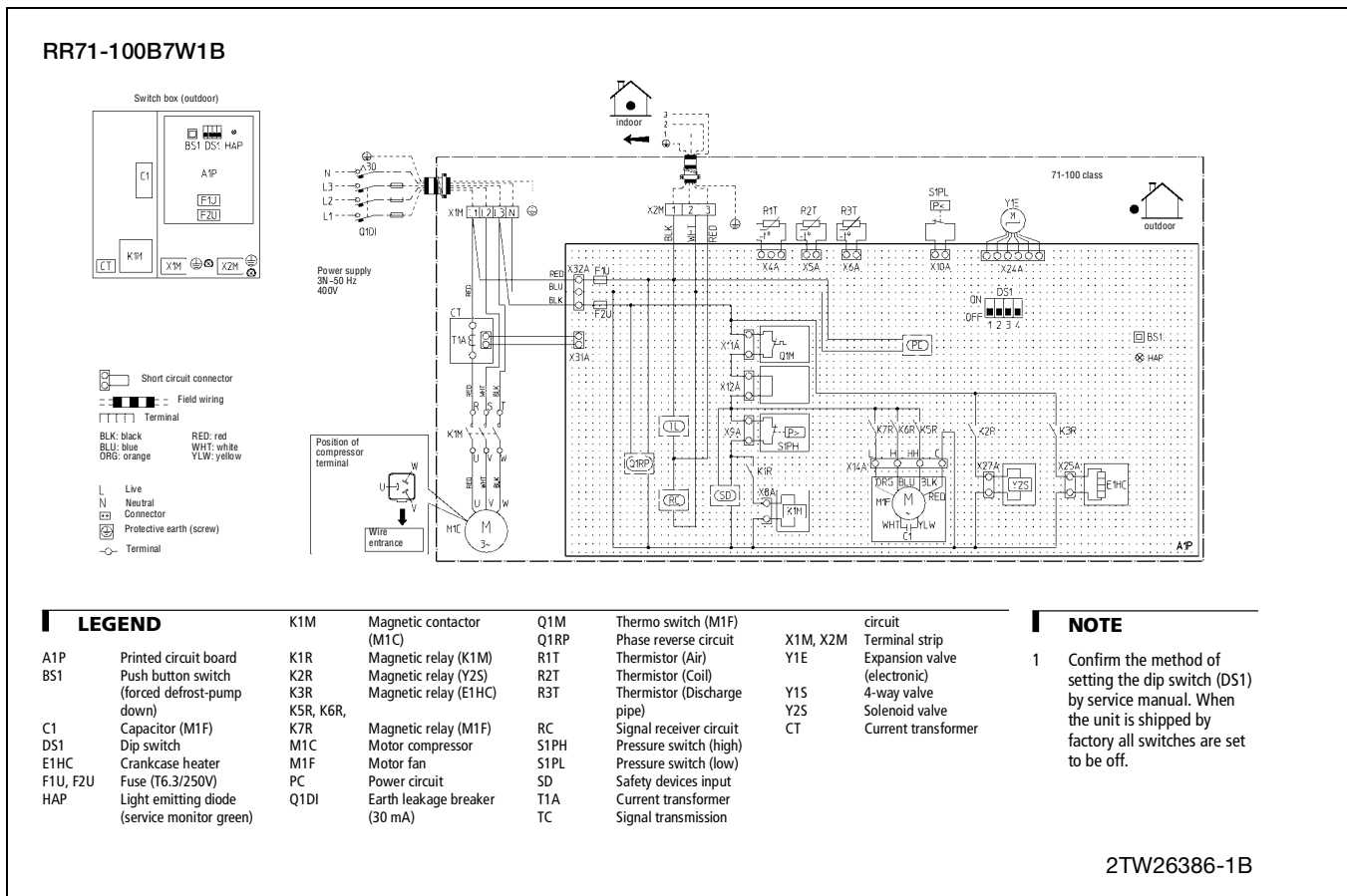
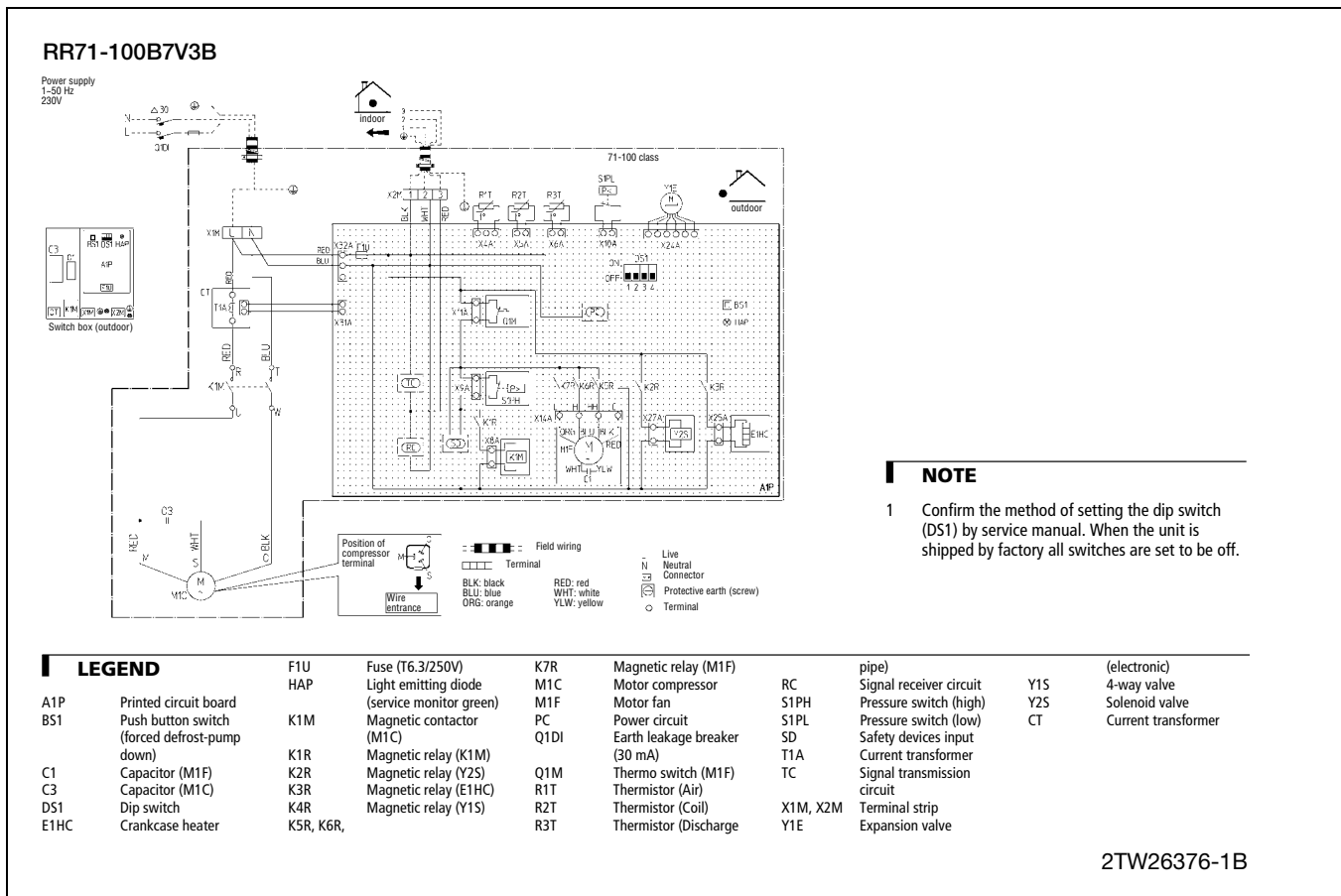

7 Wiring diagram

7 - 1 Wiring diagram

7

RR125B7W1B

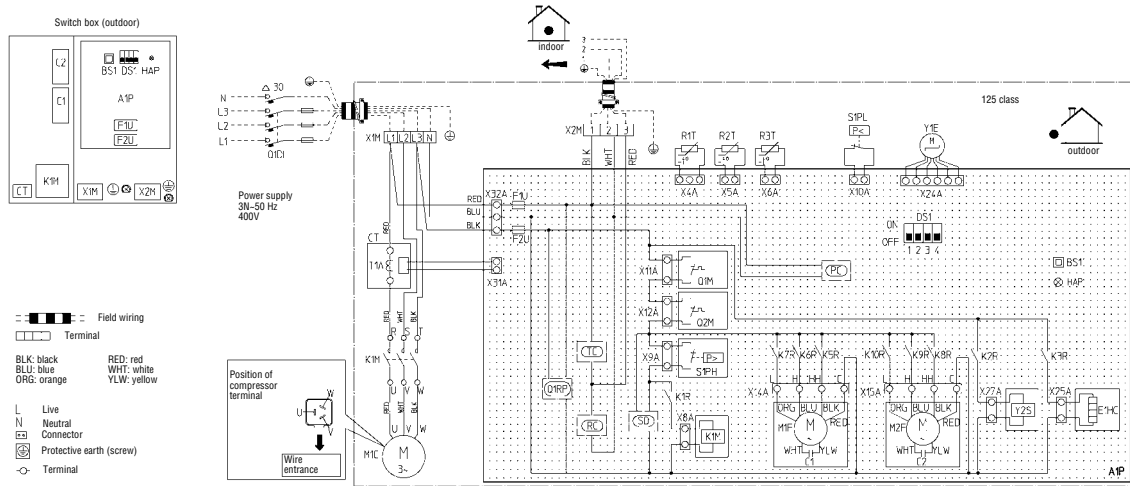

LEGEND

A1P	Printed circuit board	K1M	(service monitor green) Magnetic contactor (M1C)	M1F, M2F	Motor fan	S1PL	Pressure switch (low)
BS1	Push button switch (forced defrost-pump down)	K1R	Magnetic relay (K1M)	PC	Power circuit	SD	Safety devices input
C1	Capacitor (M1F)	K2R	Magnetic relay (Y2S)	Q1DI	Earth leakage breaker (30 mA)	T1A	Current transformer
C2	Capacitor (M2F)	K3R	Magnetic relay (E1HC)	Q1M	Thermo switch (M1F)	TC	Signal transmission circuit
DS1	Dip switch	K4R	Magnetic relay (Y1S)	Q1RP	Phase reverse circuit	X1M, X2M	Terminal strip
E1HC	Crankcase heater	K5R, K6R, K7R	Magnetic relay (M1F)	R1T	Thermistor (Air)	Y1E	Expansion valve (electronic)
F1U, F2U	Fuse (T6.3/250V)	K8R, K9R, K10R	Magnetic relay (M2F)	R2T	Thermistor (Coil)	Y1S	4-way valve
HAP	Light emitting diode	M1C	Motor compressor	R3T	Thermistor (Discharge pipe)	Y2S	Solenoid valve
				RC	Signal receiver circuit	CT	Current transformer
				S1PH	Pressure switch (high)		

NOTE

- 1 Confirm the method of setting the dip switch (DS1) by service manual. When the unit is shipped by factory all switches are set to be off.

2TW26416-1B

7 Wiring diagram

7 - 2 External connection diagram

R(Q)(R)71-125B7

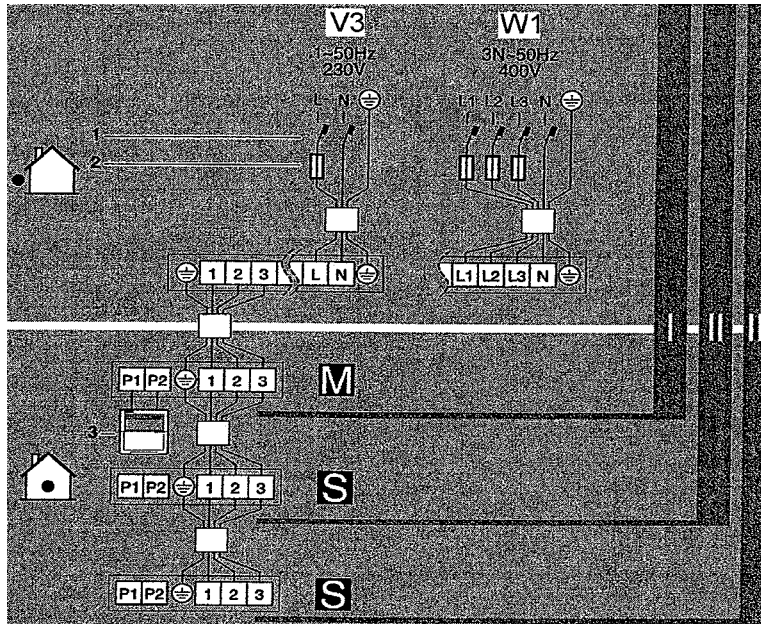

- I Pair
- II Twin
- III Triple
- M Master

- S Slave
- 1 Earth leak detector
- 2 Fuse
- 3 Remote controller

4TW26329-7

8 Sound data

8 - 1 Sound pressure spectrum

8

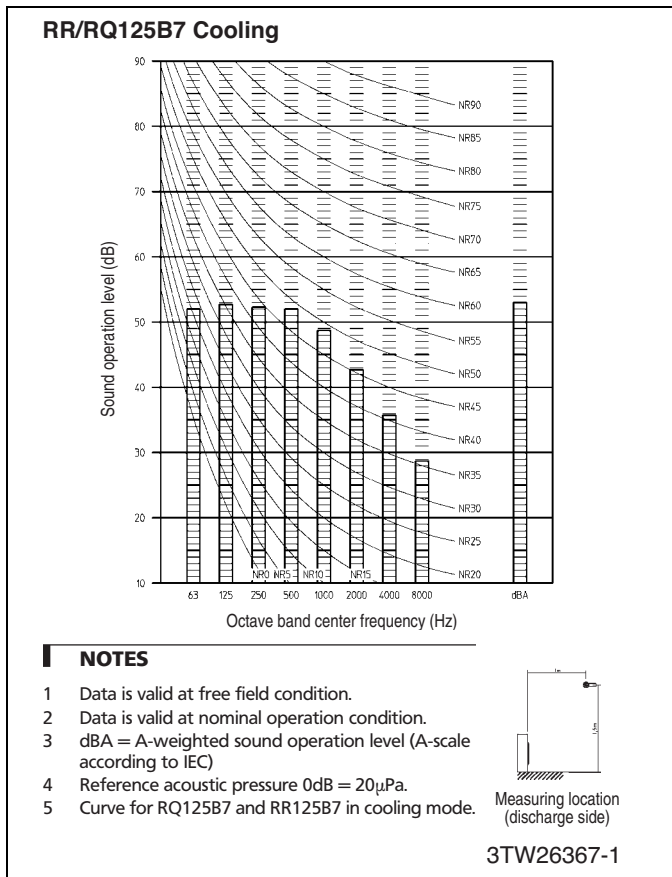
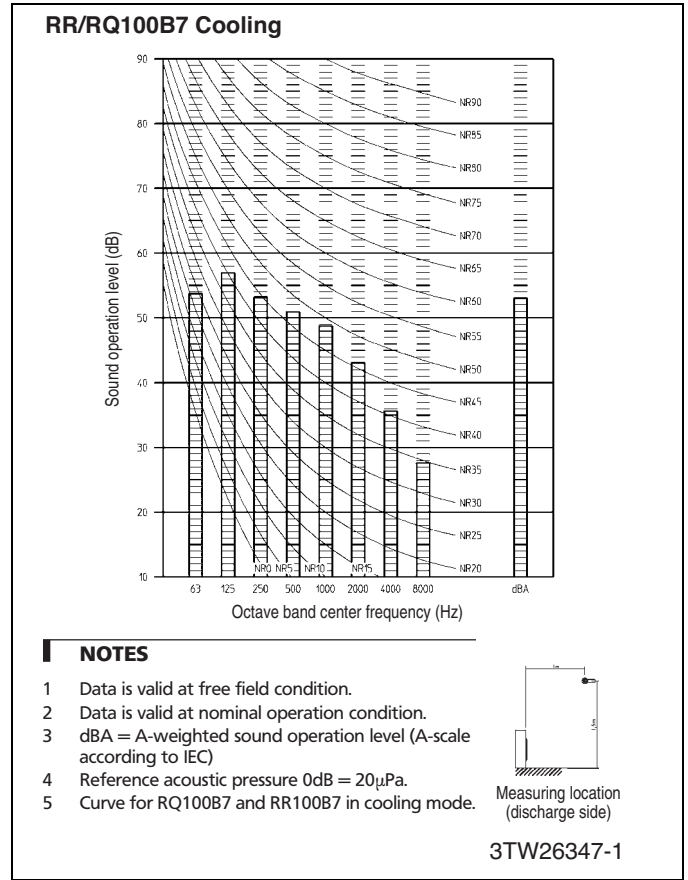
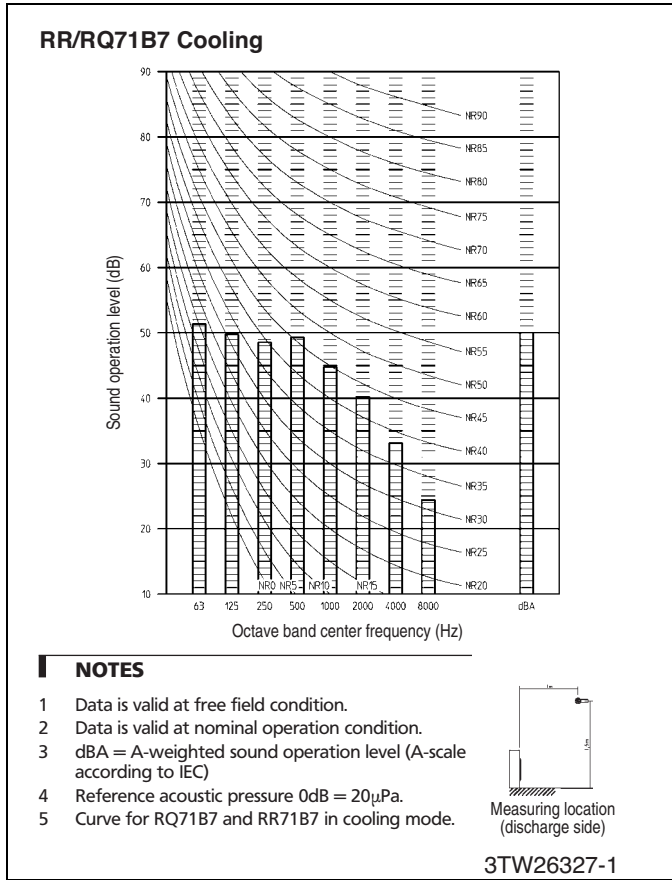

8 Sound data

8 - 2 Sound power spectrum

RR/RQ71B7 Cooling

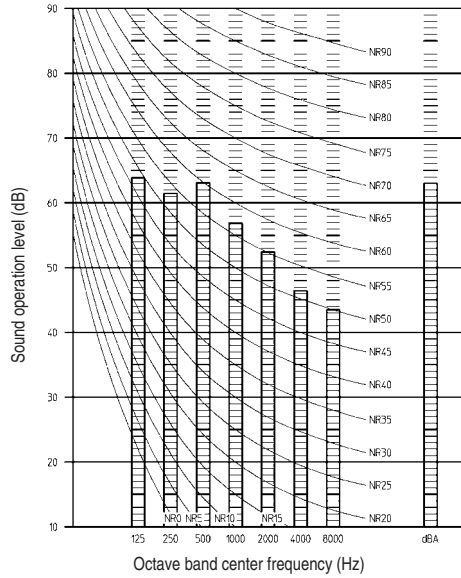

NOTE

- 1 Data is valid at free field condition.
- 2 Data is valid at nominal operation condition.
- 3 dBA = A-weighted sound operation level (A-scale according to IEC)
- 4 Reference acoustic pressure 0dB = 20μPa.
- 5 Curve for RQ100B7 and RR100B7 in cooling mode.

3TW26327-3

RR/RQ100B7 Cooling

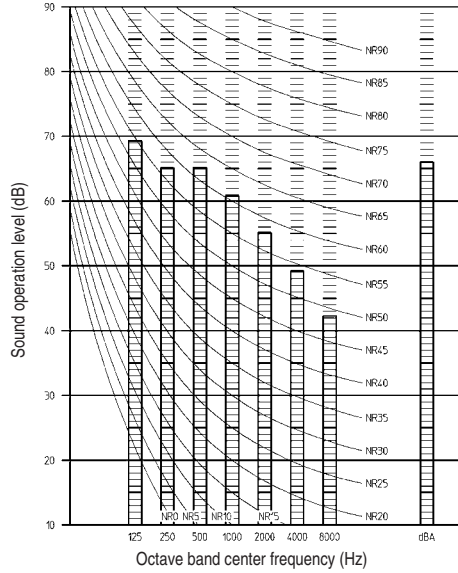

NOTE

- 1 Data is valid at free field condition.
- 2 Data is valid at nominal operation condition.
- 3 dBA = A-weighted sound operation level (A-scale according to IEC)
- 4 Reference acoustic pressure 0dB = 20μPa.
- 5 Curve for RQ100B7 and RR100B7 in cooling mode.

3TW26347-3

RR/RQ125B7 Cooling

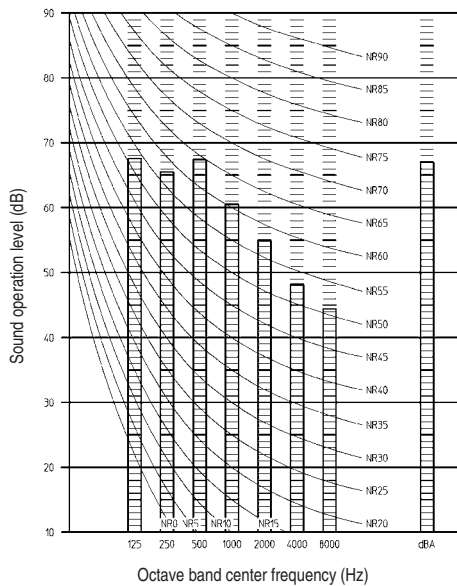

NOTE

- 1 Data is valid at free field condition.
- 2 Data is valid at nominal operation condition.
- 3 dBA = A-weighted sound operation level (A-scale according to IEC)
- 4 Reference acoustic pressure 0dB = 20μPa.
- 5 Curve for RQ125B7 and RR125B7 in cooling mode.

3TW26367-3

9 Operation range

9

RR71-125B7

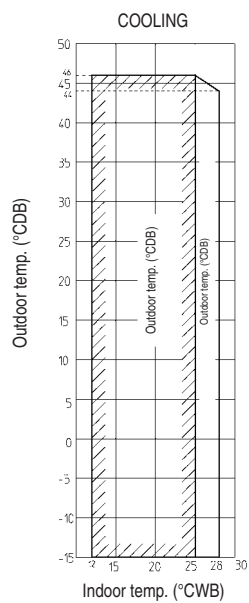

NOTES

- 1 Model names:
RR71B7V3B
RR71B7W1B
RR100B7V3B
RR100B7W1B
RR125B7W1B
- 2 Depending on operation and installation conditions, the indoor unit can change over to freeze-up operation (indoor de-icing).
- 3 To reduce the freeze-up operation (indoor de-icing) frequency it is recommended to install the outdoor unit in a location not exposed to wind.

3TW26373-1