



Air Conditioning Technical Data



EEDEN14-100

RZQG-L8/7V1

TABLE OF CONTENTS

RZQG-L8/7V1

1	Features	2
2	Specifications	3
	Nominal Capacity And Nominal Input	3
	Nominal Capacity And Nominal Input	3
	Nominal Capacity And Nominal Input	3
	Nominal Capacity And Nominal Input	4
	Nominal Capacity And Nominal Input	4
	Nominal Capacity And Nominal Input	5
	Nominal Capacity And Nominal Input	5
	Nominal Capacity And Nominal Input	6
	Technical Specifications	6
	Electrical Specifications	7
3	Electrical data	9
4	Options	12
5	Combination table	13
6	Capacity tables	14
	Cooling Capacity Tables	14
	Heating Capacity Tables	18
	Capacity Correction Factor	22
7	Dimensional drawings	23
8	Centre of gravity	24
9	Piping diagrams	25
	Piping Diagrams	25
	Piping Diagram Twin Application	26
	Piping Diagram Triple Application	27
	Piping Diagram Double Twin Application	28
10	Wiring diagrams	29
	Wiring Diagrams - Single Phase	29
11	Sound data	30
	Sound Power Spectrum	30
	Sound Pressure Spectrum - Cooling	31
	Sound Pressure Spectrum - Heating	32
	Sound Pressure Spectrum Quiet Mode	33
12	Installation	34
	Installation Method	34
13	Operation range	36

1 Features

- Seasonal smart series already comply with EU's 2014 Eco-Design requirements
- Top efficiency: - new compressor that offers substantial efficiency improvements - new control logic that optimises efficiency at the most frequently encountered operating conditions and that optimises the auxiliary modes (when the unit is not active) - newly designed heat exchangers that optimise the refrigerant flow at the most frequent operating conditions (temperature and load) - via improved nominal performances
- The perfect balance in efficiency and comfort thanks to Variable Refrigerant Temperature: top seasonal efficiency throughout most of the year and quick reaction speed on the hottest days.
- Suits computer room applications (EDP)
- Re-use of existing R-22 or R-407C technology
- Extended operation range down to -20°C in heating
- Maximum piping length up to 75m, minimum piping length is 5m.
- Daikin outdoor units are neat, sturdy and can easily be mounted on a roof or terrace or simply placed against an outside wall
- Seasonal efficiency, optimized for all seasons.
- Seasonal efficiency gives an indication on how efficient an air conditioner operates over an entire heating or cooling season.
- Compatibility with D-BACS



Inverter

2 Specifications

2-1 Nominal Capacity And Nominal Input			FCQHG71F/RZQG71L8V1	FCQHG100F/ RZQG100L8V1	FCQHG125F/ RZQG125L8V1	FCQHG140F/ RZQG140L7V1		
Cooling capacity	Nom.	kW	6.8	9.5	12.0	13.4		
Heating capacity	Nom.	kW	7.5	10.8	13.5	15.5		
Power input	Cooling	Nom.	kW	1.66	2.15	3.00	4.00	
	Heating	Nom.	kW	1.56	2.16	3.07	3.77	
Seasonal efficiency (according to EN14825)	Cooling	Energy label		A++			-	
		Pdesign	kW	6.80	9.50	12.00	-	
		SEER		7.00			6.61	-
		Annual energy consumption	kWh	340	475	635	-	
	Heating (Average climate)	Energy label		A+	A++		-	
		Pdesign	kW	7.60	11.30	12.66	-	
		SCOP		4.54	4.80	4.63	-	
		Annual energy consumption	kWh	2,343	3,296	3,829	-	
Nominal efficiency (cooling at 35°/27° nominal load, heating at 7°/20° nominal load)	EER		4.09	4.42	4.00	3.35		
	COP		4.80	4.99	4.40	4.12		
	Annual energy consumption		kWh	830	1,075	1,500	2,000	
	Energy label	Cooling	A			-		
		Heating	A			-		

Notes

(1) EER/COP according to Eurovent 2012, for use outside EU only

2-2 Nominal Capacity And Nominal Input			FCQG71F/RZQG71L8V1	FCQG100F/ RZQG100L8V1	FCQG125F/ RZQG125L8V1	FCQG140F/ RZQG140L7V1		
Cooling capacity	Nom.	kW	6.8	9.5	12.0	13.4		
Heating capacity	Nom.	kW	7.5	10.8	13.5	15.5		
Power input	Cooling	Nom.	kW	2.01	2.45	3.22	4.17	
	Heating	Nom.	kW	1.89	2.60	3.72	4.30	
Seasonal efficiency (according to EN14825)	Cooling	Energy label		A++			A+	-
		Pdesign	kW	6.80	9.50	12.00	-	
		SEER		6.80			6.00	-
		Annual energy consumption	kWh	350	489	700	-	
	Heating (Average climate)	Energy label		A+	A++	A+	-	
		Pdesign	kW	6.33	11.30	12.66	-	
		SCOP		4.20	4.61	4.10	-	
		Annual energy consumption	kWh	2,110	3,432	4,323	-	
Nominal efficiency (cooling at 35°/27° nominal load, heating at 7°/20° nominal load)	EER		3.39	3.87	3.73	3.21		
	COP		3.97	4.15	3.63	3.61		
	Annual energy consumption		kWh	1,005	1,225	1,610	2,085	
	Energy label	Cooling	A			-		
		Heating	A			-		

Notes

(1) EER/COP according to Eurovent 2012, for use outside EU only

2-3 Nominal Capacity And Nominal Input			FDQ125C/RZQG125L8V1				
Cooling capacity	Nom.	kW	12.0				
Heating capacity	Nom.	kW	13.5				
Power input	Cooling	Nom.	kW				3.20
	Heating	Nom.	kW				3.53

2 Specifications

2

2-3 Nominal Capacity And Nominal Input			FDQ125C/RZQG125L8V1	
Seasonal efficiency (according to EN14825)	Cooling	Energy label		A+
		Pdesign	kW	12.00
		SEER		5.81
		Annual energy consumption	kWh	723
	Heating (Average climate)	Energy label		A+
		Pdesign	kW	12.71
		SCOP		4.21
		Annual energy consumption	kWh	4,227
Nominal efficiency (cooling at 35°/27° nominal load, heating at 7°/20° nominal load)	EER			3.75
	COP			3.83
	Annual energy consumption		kWh	1,600
	Energy label	Cooling		A
		Heating		A

Notes

(1) EER/COP according to Eurovent 2012, for use outside EU only

2-4 Nominal Capacity And Nominal Input			FAQ71C/RZQG71L8V1		FAQ100C/RZQG100L8V1	
Cooling capacity	Nom.	kW	6.8		9.5	
Heating capacity	Nom.	kW	7.5		10.8	
Power input	Cooling	Nom.	kW	2.00		2.63
	Heating	Nom.	kW	2.03		3.00
Seasonal efficiency (according to EN14825)	Cooling	Energy label		A++		
		Pdesign	kW	6.80		9.50
		SEER		6.51		6.11
		Annual energy consumption	kWh	366		544
	Heating (Average climate)	Energy label		A+		
		Pdesign	kW	6.33		10.20
		SCOP		4.02		4.01
		Annual energy consumption	kWh	2,204		3,561
Nominal efficiency (cooling at 35°/27° nominal load, heating at 7°/20° nominal load)	EER			3.40		3.62
	COP			3.70		3.61
	Annual energy consumption		kWh	1,000		1,315
	Energy label	Cooling		A		
		Heating		A		

Notes

(1) EER/COP according to Eurovent 2012, for use outside EU only

2-5 Nominal Capacity And Nominal Input			FBQ71C8/RZQG71L8V1	FBQ100C8/RZQG100L8V1	FBQ125C8/RZQG125L8V1	FBQ140C8/RZQG140L7V1	
Cooling capacity	Nom.	kW	6.8	9.5	12.0	13.4	
Heating capacity	Nom.	kW	7.5	10.8	13.5	15.5	
Power input	Cooling	Nom.	kW	1.94	2.44	3.15	4.02
	Heating	Nom.	kW	2.05	2.57	3.53	4.30
Seasonal efficiency (according to EN14825)	Cooling	Energy label		A++	A+		-
		Pdesign	kW	6.80	9.50	12.00	-
		SEER		6.11	5.80	5.81	-
		Annual energy consumption	kWh	390	573	723	-
	Heating (Average climate)	Energy label		A+	A++	A+	-
		Pdesign	kW	6.00	11.30	12.71	-
		SCOP		4.01	4.61	4.21	-
		Annual energy consumption	kWh	2,095	3,432	4,227	-

4

2 Specifications

2-5 Nominal Capacity And Nominal Input			FBQ71C8/RZQG71L8V1	FBQ100C8/ RZQG100L8V1	FBQ125C8/ RZQG125L8V1	FBQ140C8/ RZQG140L7V1	
Nominal efficiency (cooling at 35°/27° nominal load, heating at 7°/20° nominal load)	EER		3.50	3.89	3.81	3.33	
	COP		3.65	4.21	3.83	3.61	
	Annual energy consumption		kWh	970	1,220	1,575	2,010
	Energy label	Cooling		A			-
Heating		A			-		

Notes

(1) EER/COP according to Eurovent 2012, for use outside EU only

2-6 Nominal Capacity And Nominal Input			FVQ71C/RZQG71L8V1	FVQ100C/RZQG100L8V1	FVQ125C/RZQG125L8V1	FVQ140C/RZQG140L7V1			
Cooling capacity	Nom.	kW	6.8	9.5	12.0	13.4			
Heating capacity	Nom.	kW	7.5	10.8	13.5	15.5			
Power input	Cooling	Nom.	kW	2.02	2.49	3.74	4.17		
	Heating	Nom.	kW	2.06	2.61	3.65	4.30		
Seasonal efficiency (according to EN14825)	Cooling	Energy label		A++		A+		-	
		Pdesign	kW	6.80	9.50	12.00	-		
		SEER		6.31				5.61	-
		Annual energy consumption		kWh	377	593	749	-	
	Heating (Average climate)	Energy label		A+		A		-	
		Pdesign	kW	6.33	11.30		-		
		SCOP		4.05		4.20	3.87	-	
		Annual energy consumption		kWh	2,188	3,767	4,088	-	
Nominal efficiency (cooling at 35°/27° nominal load, heating at 7°/20° nominal load)	EER		3.37	3.81	3.21				
	COP		3.64	4.14	3.70	3.61			
	Annual energy consumption		kWh	1,010	1,245	1,870	2,085		
	Energy label	Cooling		A			-		
Heating		A			-				

Notes

(1) EER/COP according to Eurovent 2012, for use outside EU only

2-7 Nominal Capacity And Nominal Input			FHQ71C/RZQG71L8V1	FHQ100C/RZQG100L8V1	FHQ125C/RZQG125L8V1	FHQ140C/RZQG140L7V1				
Cooling capacity	Nom.	kW	6.8	9.5	12.0	13.4				
Heating capacity	Nom.	kW	7.5	10.8	13.5	15.5				
Power input	Cooling	Nom.	kW	1.78	2.49	3.58	4.05			
	Heating	Nom.	kW	1.82	2.60	3.48	4.27			
Seasonal efficiency (according to EN14825)	Cooling	Energy label		A++		A+		-		
		Pdesign	kW	6.80	9.50	12.00	-			
		SEER		6.95				6.11	6.01	-
		Annual energy consumption		kWh	342	544	699	-		
	Heating (Average climate)	Energy label		A+		A++		A+		-
		Pdesign	kW	7.60	11.30	14.13	-			
		SCOP		4.32		4.61	4.23	-		
		Annual energy consumption		kWh	2,463	3,432	4,677	-		
Nominal efficiency (cooling at 35°/27° nominal load, heating at 7°/20° nominal load)	EER		3.82	3.81	3.35	3.31				
	COP		4.13	4.15	3.89	3.63				
	Annual energy consumption		kWh	890	1,245	1,790	2,025			
	Energy label	Cooling		A			-			
Heating		A			-					

Notes

(1) EER/COP according to Eurovent 2012, for use outside EU only

2 Specifications

2

2-8 Nominal Capacity And Nominal Input				FUQ71C/RZQG71L8V1	FUQ100C/RZQG100L8V1	FUQ125C/RZQG125L8V1
Cooling capacity	Nom.		kW	6.8	9.5	12.0
Heating capacity	Nom.		kW	7.5	10.8	13.5
Power input	Cooling	Nom.	kW	1.68	2.46	3.54
	Heating	Nom.	kW	1.84	2.73	3.95
Seasonal efficiency (according to EN14825)	Cooling	Energy label		A++		A+
		Pdesign	kW	6.80	9.50	12.00
		SEER		6.50	6.11	5.61
		Annual energy consumption	kWh	366	544	749
	Heating (Average climate)	Energy label		A+		
		Pdesign	kW	7.60	11.30	14.13
		SCOP		4.20	4.50	4.44
		Annual energy consumption	kWh	2,533	3,516	4,456
Nominal efficiency (cooling at 35°/27° nominal load, heating at 7°/20° nominal load)	EER			4.05	3.86	3.39
	COP			4.08	3.95	3.42
	Annual energy consumption		kWh	840	1,230	1,770
	Energy label	Cooling		A		
		Heating		A		B

Notes

(1) EER/COP according to Eurovent 2012, for use outside EU only

2-9 Technical Specifications				RZQG71L8V1	RZQG100L8V1	RZQG125L8V1	RZQG140L7V1	
Capacity control	Method			Inverter controlled				
Casing	Colour			Ivory white				
	Material			Painted galvanized steel plate				
Dimensions	Unit	Height	mm	990	1,430			
		Width	mm	940				
		Depth	mm	320				
	Packed unit	Height	mm	1,170	1,610			
		Width	mm	1,015				
		Depth	mm	422				
Weight	Unit		kg	78	102			
	Packed unit		kg	88	115			
Heat exchanger	Fin	Type		WF fin				
		Treatment		Anti-corrosion treatment (PE)				
Compressor	Quantity			1				
	Type			Hermetically sealed swing compressor				
	Starting method			Inverter driven				
Fan	Type			Propeller fan				
	Discharge direction			Horizontal				
	Quantity			1	2			
	Air flow rate	Cooling	Nom.	m ³ /min	59	70	84	
			Super low	m ³ /min cfm	-			
		Heating	Nom.	m ³ /min	49	62		
Super low			m ³ /min cfm	-				
Fan motor	Quantity			1	2			
	Model			Brushless DC motor				
	Output			W				
	Drive			Direct drive				
	Speed	Cooling	Super low	rpm	-			
			Heating	Super low	rpm	-		

2 Specifications

2-9 Technical Specifications				RZQG71L8V1	RZQG100L8V1	RZQG125L8V1	RZQG140L7V1
Sound power level	Cooling		dBA	64	66	67	69
	Heating		dBA	-			
Sound pressure level	Cooling	Nom.	dBA	48	50	51	52
	Heating	Nom.	dBA	50	52	53	
	Night quiet mode	Level 1	dBA	43	45		
Operation range	Cooling	Ambient	Min.	°CDB -15			
			Max.	°CDB 50			
	Heating	Ambient	Min.	°CWB -20			
			Max.	°CWB 15.5			
Refrigerant	Type			R-410A			
	Charge		kg	2.9	4.0		
	Control			Expansion valve (electronic type)			
	GWP			1,975			
	Circuits	Quantity		1			
Refrigerant oil	Type			FVC50K			
	Charged volume		l	0.9	1.35		
Piping connections	Liquid	Quantity		1			
		Type		Flare connection			
		OD	mm	9.52			
	Gas	Quantity		1			
		Type		Flare connection			
		OD	mm	15.9			
	Drain	Quantity		5			
		Type		Hole			
		ID	mm	-			
		OD	mm	26			
	Piping length	OU - IU	Min.	m 5			
			Max.	m 50		m 75	
		System	Equivalent	m 70		m 90	
			Chargeless	m 30			
	Additional refrigerant charge			kg/m See installation manual			
Level difference	IU - OU	Max.	m 30.0				
	IU - IU	Max.	m 0.5				
Heat insulation			Both liquid and gas pipes				
Defrost method			Reversed cycle				
Defrost control			Sensor for outdoor heat exchanger temperature				
Safety devices	Item	01	High pressure switch				
		02	Fan driver overload protector				
		03	Fuse				

2-10 Electrical Specifications				RZQG71L8V1	RZQG100L8V1	RZQG125L8V1	RZQG140L7V1
Power supply	Name			V1			
	Phase			1~			
	Frequency		Hz	50			
	Voltage		V	220-240			
	Voltage range	Min.	%	10			
		Max.	%	10			
Current	Zmax	List	Complies to EN61000-3-11				
	Recommended fuses		A	25	40		
Current - 50Hz	Maximum fuse amps (MFA)		A	20	32		
Current - 60Hz	Maximum fuse amps (MFA)		A	-			
Wiring connections	For power supply	Remark		See installation manual outdoor unit			
	For connection with indoor	Remark		See installation manual outdoor unit			
Power supply intake			Outdoor unit only				

2 Specifications

Notes

- (1) PED: assembly = category I : excluded from scope of PED due to article 1, item 3.6 of 97/23/EC
- (2) Equipment complying with EN/IEC 61000-3-12: European/international technical standard setting the limits for harmonic currents produced by equipment connected to public low-voltage system with input current $> 16\text{A}$ and $\leq 75\text{A}$ per phase
- (3) See separate drawing for electrical data
- (4) 3 with re-charging

3 Electrical data

3 - 1 Electrical Data

RZQG71-100L8V1

Indoor	Outdoor	Hz-Power supply	Voltage range	MCA	TOCA	MFA	Comp		OFM		IFM				
							MSC	RLA	kW	FLA	kW	FLA			
FCQHG71FVEB	RZQG71L8V1	50Hz~220-240V	Min. 198V Max. 264V	18,2	—	20	—	15,6	0,094	0,4	0,091	0,5			
FCQG35FVEB				x2	18,4	—	20	—	15,6	0,094	0,4	0,044x2	0,3x2		
FCQG71FVEB					18,1	—	20	—	15,6	0,094	0,4	0,054	0,4		
FFQ35B9V1B				x2	18,6	—	20	—	15,6	0,094	0,4	0,055x2	0,4x2		
FBQ35C8VEB				x2	20,6	—	25	—	15,6	0,094	0,4	0,140x2	1,2x2		
FBQ71C8VEB					19,0	—	20	—	15,6	0,094	0,4	0,350	1,1		
FHQ35BWV1B				x2	19,1	—	20	—	15,6	0,094	0,4	0,062x2	0,6x2		
FHQG71CVEB					18,6	—	20	—	15,6	0,094	0,4	0,091	0,8		
FUQ71BWV1B					18,4	—	20	—	15,6	0,094	0,4	0,180	0,6		
FAQ71CVEB					18,1	—	20	—	15,6	0,094	0,4	0,048	0,4		
FVQ71CVEB					18,4	—	20	—	15,6	0,094	0,4	0,117	0,6		
FHQ35CAVEB				x2	19,1	—	20	—	15,6	0,094	0,4	0,060 x 2	0,6 x 2		
FHQ71CAVEB					18,6	—	20	—	15,6	0,094	0,4	0,091	0,8		
FUQ71CVEB					18,7	—	20	—	15,6	0,094	0,4	0,046	0,9		
FCQHG100FVEB				RZQG100L8V1	50Hz~220-240V	Min. 198V Max. 264V	29,1	—	32	—	24,2	0,094+0,094	0,4+0,4	0,221	1,3
FCQG35FVEB							x3	28,6	—	32	—	24,2	0,094+0,094	0,4+0,4	0,044x3
FCQG50FVEB	x2	28,3	—				32	—	24,2	0,094+0,094	0,4+0,4	0,039x2	0,3x2		
FCQG100FVEB		28,4	—				32	—	24,2	0,094+0,094	0,4+0,4	0,117	0,7		
FFQ35B9V1B	x3	29,0	—				32	—	24,2	0,094+0,094	0,4+0,4	0,055x3	0,4x3		
FFQ50B9V1B	x2	29,3	—				32	—	24,2	0,094+0,094	0,4+0,4	0,055x2	0,7x2		
FBQ35C8VEB	x3	32,0	—				40	—	24,2	0,094+0,094	0,4+0,4	0,140x3	1,2x3		
FBQ50C8VEB	x2	30,5	—				32	—	24,2	0,094+0,094	0,4+0,4	0,140x2	1,2x2		
FBQ100C8VEB		29,5	—				32	—	24,2	0,094+0,094	0,4+0,4	0,350	1,6		
FHQ35BWV1B	x3	29,8	—				32	—	24,2	0,094+0,094	0,4+0,4	0,062x3	0,6x3		
FHQ50BWV1B	x2	29,0	—				32	—	24,2	0,094+0,094	0,4+0,4	0,062x2	0,6x2		
FHQG100CVEB		29,0	—				32	—	24,2	0,094+0,094	0,4+0,4	0,150	1,2		
FUQ100BWV1B		28,8	—				32	—	24,2	0,094+0,094	0,4+0,4	0,289	1,0		
FAQ100CVEB		28,0	—				32	—	24,2	0,094+0,094	0,4+0,4	0,064	0,4		
FVQ100CVEB		29,0	—				32	—	24,2	0,094+0,094	0,4+0,4	0,238	1,2		
FHQ35CAVEB	x3	29,8	—				32	—	24,2	0,094+0,094	0,4+0,4	0,060 x 3	0,6 x 3		
FHQ50CAVEB	x2	29,0	—	32	—	24,2	0,094+0,094	0,4+0,4	0,060 x 2	0,6 x 2					
FHQ100CAVEB		29,1	—	32	—	24,2	0,094+0,094	0,4+0,4	0,150	1,3					
FUQ100CVEB		29,1	—	32	—	24,2	0,094+0,094	0,4+0,4	0,106	1,3					

SYMBOLS

MCA	: Min. Circuit Amps. (A)
TOCA	: Total Over-Current Amps. (A)
MFA	: Max. Fuse Amps. (See note 7) (A)
MSC	: Max. current during the starting compressor. (A)
RLA	: Rated Load Amps. (A)
OFM	: Outdoor Fan Motor. (A)
IFM	: Indoor Fan Motor.
FLA	: Full Load Amps.
kW	: Fan Motor Rated Output. (kW)

NOTES

- 1 RLA is based on the following conditions:
Power supply: 50Hz 230V
Cooling
Indoor temperature 27.0°CDB/19.0°CWB
Outdoor temperature 35.0°CDB
Heating
Indoor temperature 20.0°CDB
Outdoor temperature 7.0°CDB / 6.0°CWB
- 2 TOCA means the total value of each OC set.
- 3 Voltage range
Units are suitable for use on electrical systems where voltage supplied to unit terminals is not below or above listed range limits.
- 4 Maximum allowable voltage variation between phases is 2%.
- 5 MCA represents maximum input current. MFA represents capacity which may accept MCA. (next lower standard fuse rating, min.15A)
- 6 Select wire size based on the larger value of MCA or TOCA.
- 7 MFA is used to select the circuit breaker and the ground fault circuit interrupter. (earth leakage circuit breaker)

3D076356A

3 Electrical data

3 - 1 Electrical Data

RZQG125-140L8/7V1

Indoor	Outdoor	Hz Power supply	Voltage range	Comp					OFM		IFM				
				MCA	TOCA	MFA	MSC	RLA	kW	FLA	kW	FLA			
FCQHG125FVEB	RZQG125L8V1	50Hz~ 220-240V	Min. 198V Max. 264V	29,3	—	32	—	24,2	0.094+0.094	0.4+0.4	0,244	1,4			
FCQG35FVEB x4				29,0	—	32	—	24,2	0.094+0.094	0.4+0.4	0,044x4	0,3x4			
FCQG50FVEB x3				28,6	—	32	—	24,2	0.094+0.094	0.4+0.4	0,039x3	0,3x3			
FCQG60FVEB x2				28,3	—	32	—	24,2	0.094+0.094	0.4+0.4	0,044x2	0,3x2			
FCQG125FVEB				28,8	—	32	—	24,2	0.094+0.094	0.4+0.4	0,168	1,0			
FFQ35B9V1B x4				29,5	—	32	—	24,2	0.094+0.094	0.4+0.4	0,055x4	0,4x4			
FFQ50B9V1B x3				30,1	—	32	—	24,2	0.094+0.094	0.4+0.4	0,055x3	0,7x3			
FFQ60B9V1B x2				29,3	—	32	—	24,2	0.094+0.094	0.4+0.4	0,055x2	0,7x2			
FBQ35C8VEB x4				33,5	—	40	—	24,2	0.094+0.094	0.4+0.4	0,140x4	1,2x4			
FBQ50C8VEB x3				32,0	—	40	—	24,2	0.094+0.094	0.4+0.4	0,140x3	1,2x3			
FBQ60C8VEB x2				30,3	—	32	—	24,2	0.094+0.094	0.4+0.4	0,350x2	1,1x2			
FBQ125C8VEB				30,1	—	32	—	24,2	0.094+0.094	0.4+0.4	0,350	2,1			
FHQ35BWW1B x4				30,5	—	32	—	24,2	0.094+0.094	0.4+0.4	0,062x4	0,6x4			
FHQ50BWW1B x3				29,8	—	32	—	24,2	0.094+0.094	0.4+0.4	0,062x3	0,6x3			
FHQ60BWW1B x2				29,0	—	32	—	24,2	0.094+0.094	0.4+0.4	0,062x2	0,6x2			
FHQG125CVEB				29,5	—	32	—	24,2	0.094+0.094	0.4+0.4	0,150	1,6			
FUQ125BWW1B				28,8	—	32	—	24,2	0.094+0.094	0.4+0.4	0,289	1,0			
FDQ125C7VEB				30,1	—	32	—	24,2	0.094+0.094	0.4+0.4	0,350	2,1			
FVQ125CVEB				29,0	—	32	—	24,2	0.094+0.094	0.4+0.4	0,238	1,2			
FHQ35CAVEB x4				30,5	—	32	—	24,2	0.094+0.094	0.4+0.4	0,060 x 4	0,6 x 4			
FHQ50CAVEB x3				29,8	—	32	—	24,2	0.094+0.094	0.4+0.4	0,060 x 3	0,6 x 3			
FHQ60CAVEB x2				29,0	—	32	—	24,2	0.094+0.094	0.4+0.4	0,091 x 2	0,6 x 2			
FHQ125CAVEB				29,4	—	32	—	24,2	0.094+0.094	0.4+0.4	0,150	1,5			
FUQ125CVEB				29,3	—	32	—	24,2	0.094+0.094	0.4+0.4	0,106	1,4			
FCQHG71FVEB x2				RZQG140L7V1	50Hz~ 220-240V	Min. 198V Max. 264V	28,8	—	32	—	24,2	0.094+0.094	0.4+0.4	0,091x2	0,5x2
FCQHG140FVEB							29,3	—	32	—	24,2	0.094+0.094	0.4+0.4	0,244	1,4
FCQG35FVEB x4							29,0	—	32	—	24,2	0.094+0.094	0.4+0.4	0,044x4	0,3x4
FCQG50FVEB x3							28,6	—	32	—	24,2	0.094+0.094	0.4+0.4	0,039x3	0,3x3
FCQG71FVEB x2							28,5	—	32	—	24,2	0.094+0.094	0.4+0.4	0,054x2	0,4x2
FCQG140FVEB							28,8	—	32	—	24,2	0.094+0.094	0.4+0.4	0,168	1,0
FFQ35B9V1B x4							29,5	—	32	—	24,2	0.094+0.094	0.4+0.4	0,055x4	0,4x4
FFQ50B9V1B x3							30,1	—	32	—	24,2	0.094+0.094	0.4+0.4	0,055x3	0,7x3
FBQ35C8VEB x4	33,5	—	40				—	24,2	0.094+0.094	0.4+0.4	0,140x4	1,2x4			
FBQ50C8VEB x3	32,0	—	40				—	24,2	0.094+0.094	0.4+0.4	0,140x3	1,2x3			
FBQ71C8VEB x2	30,3	—	32				—	24,2	0.094+0.094	0.4+0.4	0,350x2	1,1x2			
FBQ140C8VEB	30,1	—	32				—	24,2	0.094+0.094	0.4+0.4	0,350	2,1			
FHQ35BWW1B x4	30,5	—	32				—	24,2	0.094+0.094	0.4+0.4	0,062x4	0,6x4			
FHQ50BWW1B x3	29,8	—	32				—	24,2	0.094+0.094	0.4+0.4	0,062x3	0,6x3			
FHQG71CVEB x2	29,5	—	32				—	24,2	0.094+0.094	0.4+0.4	0,091x2	0,8x2			
FHQG140CVEB	29,8	—	32				—	24,2	0.094+0.094	0.4+0.4	0,150	1,8			
FUQ71BWW1B x2	29,0	—	32				—	24,2	0.094+0.094	0.4+0.4	0,180x2	0,6x2			
FAQ71CVEB x2	28,5	—	32				—	24,2	0.094+0.094	0.4+0.4	0,048x2	0,4x2			
FVQ140CVEB	29,3	—	32				—	24,2	0.094+0.094	0.4+0.4	0,276	1,4			
FHQ35CAVEB x4	30,5	—	32				—	24,2	0.094+0.094	0.4+0.4	0,060 x 4	0,6 x 4			
FHQ50CAVEB x3	29,8	—	32				—	24,2	0.094+0.094	0.4+0.4	0,060 x 3	0,6 x 3			
FHQ71CAVEB x2	29,5	—	32				—	24,2	0.094+0.094	0.4+0.4	0,091 x 2	0,8 x 2			
FHQ140CAVEB	29,8	—	32				—	24,2	0.094+0.094	0.4+0.4	0,150	1,8			
FUQ71CVEB x2	29,8	—	32				—	24,2	0.094+0.094	0.4+0.4	0,046 x 2	0,9 x 2			

SYMBOLS

MCA	: Min. Circuit Amps. (A)
TOCA	: Total Over-Current Amps. (A)
MFA	: Max. Fuse Amps (See note 7) (A)
MSC	: Max. current during the starting compressor. (A)
RLA	: Rated Load Amps. (A)
OFM	: Outdoor Fan Motor. (A)
IFM	: Indoor Fan Motor.
FLA	: Full Load Amps.
kW	: Fan Motor Rated Output (kW)

NOTES

- RLA is based on the following conditions:
Power supply: 50Hz 230V
Cooling
Indoor temperature 27.0°CDB/19.0°CWB
Outdoor temperature 35.0°CDB
Heating
Indoor temperature 20.0°CDB
Outdoor temperature 7.0°CDB / 6.0°CWB
- TOCA means the total value of each OC set.
- Voltage range
Units are suitable for use on electrical systems where voltage supplied to unit terminals is not below or above listed range limits.
- Maximum allowable voltage variation between phases is 2%.
- MCA represents maximum input current. MFA represents capacity which may accept MCA.
(next lower standard fuse rating, min.15A)
- Select wire size based on the larger value of MCA or TOCA.
- MFA is used to select the circuit breaker and the ground fault circuit interrupter.
(earth leakage circuit breaker)

3D076356A

3 Electrical data

3 - 1 Electrical Data

RZQG-L8/7V1

	FBQ35C8	FBQ50C8	FBQ60C8	FBQ71C8	FBQ100C8	FBQ125C8	FBQ140C8
RZQG71L8V1	2 (77.1)			P (89.7)			
RZQG100L8V1	3 (97.3)	2 (77.1)			P (89.7)		
RZQG125L8V1	3/4 (116.2)	3 (97.3)	2 (138.1)			P (89.7)	
RZQG140L7V1	4 (116.2)	3 (97.3)		2 (138.1)			P (89.7)

P = Pair
 2 =Twin
 3 =Triple
 4 =Double twin

4D076495

NOTES

- In accordance with EN/IEC 61000-3-12⁽¹⁾, it may be necessary to consult the distribution network operator to ensure that the equipment is connected only to a supply with $S_{sc}^{(2)} \geq$ minimum Ssc value.

- ⁽¹⁾ European/international technical standard setting the limits for harmonic currents produced by equipment connected to public low-voltage system with input current > 16A and \leq 75A per phase.

⁽²⁾ Short-circuit power

4 Options

4 - 1 Options

4

RZQG-L8/7V1

Available options for RZQG models:

Name of option	Kit name			
	RZQG71L8V1	RZQG100L8V1	RZQG125L8V1	RZQG140L7V1
Bottom plate heater	EKBPH140L7: See note 1			
Refrigerant branch piping	Twin	KHRQ22M20TA (KHRQ58T): See note 2		
	Triple	-	KHRQ127H (KHRQ58H): See note 2	
	Double twin	-	-	KHRQ22M20TA (KHRQ58T): See note 2 (3x)
Demand adapter kit	KRP58M51			

3D076079

NOTES

- 1 For combination of RZQG71L8V1 and EKBPH140L7 it is required to use the demand adapter kit KRP58M51 in order to connect the bottom plate heater.
- 2 For RZQ(S)G71-140L8Y1 in combination with FCQG35-71F or FCQH71F use the refrigerant branch piping mentioned between brackets.

6 Capacity tables

6 - 1 Cooling Capacity Tables

6

RZQG71L8V1

Cooling

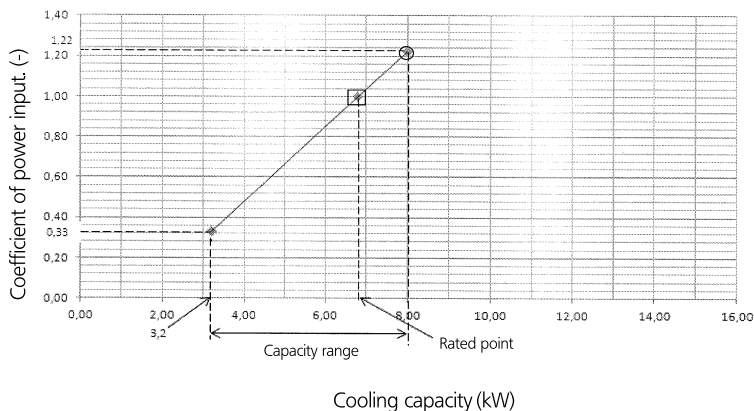

Cooling

Indoor		Outdoor temperature (°CDB)											
		25			30			35			40		
°CWB	°CDB	TC kW	SHC kW	CPI -	TC kW	SHC kW	CPI -	TC kW	SHC kW	CPI -	TC kW	SHC kW	CPI -
16.0	22	8.09	5.45	1.00	7.76	5.32	1.11	7.48	5.20	1.21	7.21	5.06	1.32
18.0	25	8.40	5.45	1.00	8.11	5.32	1.11	7.83	5.19	1.22	7.54	5.05	1.33
19.0	27	8.59	5.44	1.01	8.30	5.32	1.12	8.00	5.18	1.22	7.70	5.05	1.33
19.5	27	8.68	5.43	1.01	8.39	5.31	1.12	8.09	5.17	1.22	7.79	5.05	1.33
22.0	30	9.15	5.38	1.01	8.84	5.25	1.12	8.52	5.13	1.23	8.21	4.99	1.34
24.0	32	9.53	5.31	1.03	9.20	5.19	1.13	8.87	5.06	1.25	8.54	4.92	1.35

NOTES

- Ratings shown are net capacities which include a deduction for indoor fan motor heat.
- On the figure the mark with ○ show the max. at standard conditions.
On the figure the mark with □ show the rated capacity and rated coefficient of power input.
However the max. capacity is not guaranteed, except at standard condition.
- SHC is based on indoor EWB and EDB.
SHC for other dry bulb temp. = SHC + SHC*.
SHC* = SHC correction for other dry bulb.
= 0.02 x AFR (m³/min.) x (1-BF) x (DB*-EDB).
- Capacities are based on the following conditions:
Outdoor air: 85% RH.
However, the condition rated capacity in heating is 7° CDB / 6° CWB.
Corresponding refrigerant piping length: 5.0 m.
Level difference: 0 m.
- Coefficient of power input is the percentage when the rated value is defined as 1.00.
- The value contains less than 5% error according to indoor unit type.
- Heating performance include the drop of frost formation.
- Air flow rate and (BF) are given in table below:

(Pair)

	FCQG71F	FCQG71F	FBQ71C	FHQG71C	FUQ71BW	FAQ71C	PVQ71C	FHQ71CA	FUQ71C
AFR	21.2	21.5	18.0	20.5	19.0	18.0	18.0	20.5	23.0
(BF)	(0.2)	(0.14)	(0.08)	(0.13)	(0.07)	(0.16)	(0.16)	(0.13)	(0.24)

(Twin)

	FCQG35Fx2	FFQ35B9x2	FBQ35Cx2	FHQ35BvWx2	FHQ35CAx2
AFR	12.5x2	10x2	16x2	13x2	14x2
(BF)	(0.4x2)	(0.25x2)	(0.15x2)	(0.20x2)	(0.17x2)

- Rated power input of each model is given in tables below:

(Pair)

	FCQG71F	FCQG71F	FBQ71C	FHQG71C	FUQ71BW	FAQ71C	PVQ71C	FHQ71CA	FUQ71C
Cooling	1.66	2.01	1.94	1.78	1.68	2.00	2.02	1.78	1.67

(Twin)

	FCQG35Fx2	FFQ35B9x2	FBQ35Cx2	FHQ35BvWx2	FHQ35CAx2
Cooling	2.04	2.14	1.98	2.38	2.34

SYMBOLS

- AFR: Air flow rate (m³/min)
 BF: Bypass factor
 EWB: Entering wet bulb temp. (°CWB)
 EDB: Entering dry bulb temp. (°CDB)
 TC: Maximum Total cooling (heating) capacity (kW)
 SHC: Sensible heat capacity (kW)
 PI: Power input
 (comp.+indoor and outdoor fan motor)
 CPI: Coefficient of power input. (-)

Caution:
TC and SHC are shown by kW.

3D076748A

6 Capacity tables

6 - 1 Cooling Capacity Tables

RZQG100L8V1

Cooling

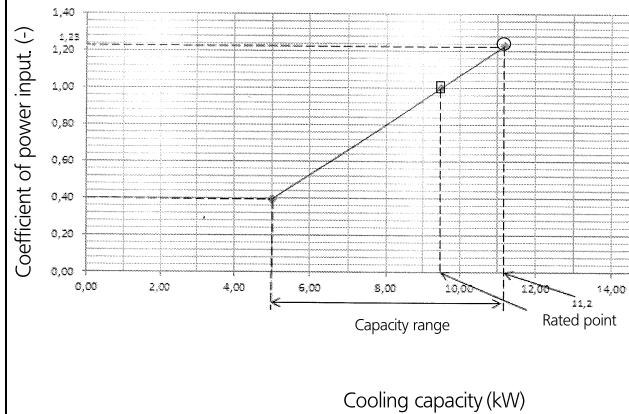

Cooling

Indoor		Outdoor temperature (°CDB)											
		25			30			35			40		
°CWB	°CDB	TC kW	SHC kW	CPI	TC kW	SHC kW	CPI	TC kW	SHC kW	CPI	TC kW	SHC kW	CPI
16.0	22	11.2	7.61	1.01	10.8	7.44	1.11	10.5	7.29	1.22	10.1	7.09	1.32
18.0	25	11.8	7.59	1.01	11.4	7.49	1.12	11.0	7.27	1.23	10.5	7.09	1.33
19.0	27	12.0	7.57	1.02	11.6	7.44	1.12	11.2	7.26	1.23	10.8	7.04	1.33
19.5	27	12.1	7.59	1.02	11.7	7.37	1.13	11.4	7.34	1.23	10.9	7.04	1.34
22.0	30	12.8	7.52	1.02	12.4	7.36	1.13	11.9	7.16	1.24	11.5	7.03	1.35
24.0	32	13.3	7.42	1.03	12.9	7.27	1.14	12.4	7.06	1.25	12.0	6.91	1.36

NOTES

- Ratings shown are net capacities which include a deduction for indoor fan motor heat.
- On the figure the mark with ○ show the max. at standard conditions.
On the figure the mark with □ show the rated capacity and rated coefficient of power input.
However the max. capacity is not guaranteed, except at standard condition.
- SHC is based on indoor EWB and EDB.
SHC for other dry bulb temp. = SHC + SHC*.
SHC* = SHC correction for other dry bulb.
= 0.02 x AFR (m³/min.) x (1-BF) x (DB* - EDB).
- Capacities are based on the following conditions:
Outdoor air: 85% RH.
However, the condition rated capacity in heating is 7° CDB / 6° CWB.
Corresponding refrigerant piping length: 5.0 m.
Level difference: 0 m.
- Coefficient of power input is the percentage when the rated value is defined as 1.00.
- The value contains less than 5% error according to indoor unit type.
- Heating performance include the drop of frost formation.
- Air flow rate and (BF) are given in table below:

(Pair)

	FCQH100F	FCQG100F	FBQ100C	FHQG100C	FUQ100BW	FAQ100C	FVQ100C	FHQ100CA	FUQ100C
AFR	32.3	32.0	32.0	20.0	29.0	26.0	28.0	28.0	31.0
(BF)	(0.17)	(0.17)	(0.13)	(0.09)	(0.07)	(0.10)	(0.20)	(0.09)	(0.20)

(Triple)

	FCQG35F3	FFQ35B9x3	FBQ35C3	FHQ35BWx3	FHQ35CAx3
AFR	12.5x3	10x3	16x3	13x3	14x3
(BF)	(0.4x3)	(0.25x3)	(0.15x3)	(0.20x3)	(0.17x3)

- Rated power input of each model is given in tables below:

(Pair)

	FCQH100F	FCQG100F	FBQ100C	FHQG100C	FUQ100BW	FAQ100C	FVQ100C	FHQ100CA	FUQ100C
Cooling	2.15	2.45	2.44	2.49	2.46	2.63	2.49	2.49	2.33

(Triple)

	FCQG35F3	FFQ35B9x3	FBQ35C3	FHQ35BWx3	FHQ35CAx3
Cooling	2.38	2.44	2.51	2.97	2.91

SYMBOLS

- AFR: Air flow rate (m³/min)
- BF: Bypass factor
- EWB: Entering wet bulb temp. (°CWB)
- EDB: Entering dry bulb temp. (°CDB)
- TC: Maximum Total cooling (heating) capacity (kW)
- SHC: Sensible heat capacity (kW)
- PI: Power input
(comp.+indoor and outdoor fan motor)
- CPI: Coefficient of power input. (-)

Caution:
TC and SHC are shown by kW.

(Twin)

	FCQG50F2	FFQ50B9x2	FBQ50C2	FHQ50BWx2	FHQ50CAx2
AFR	12.6x2	12x2	16x2	13x2	15x2
(BF)	(0.22x2)	(0.16x2)	(0.16x2)	(0.10x2)	(0.18x2)

(Twin)

	FCQG50F2	FFQ50B9x2	FBQ50C2	FHQ50BWx2	FHQ50CAx2
Cooling	2.32	2.44	2.51	2.97	2.93

3D076749A

6 Capacity tables

6 - 1 Cooling Capacity Tables

6

RZQG125L8V1

Cooling

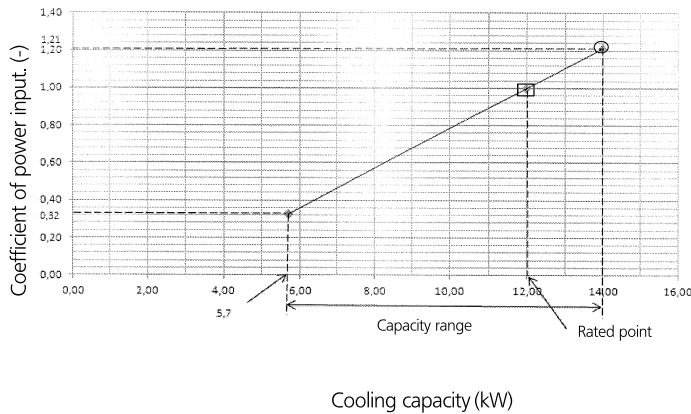

Cooling

Indoor		Outdoor temperature (°CDB)											
		25			30			35			40		
°CWB	°CDB	TC kW	SHC kW	CPI	TC kW	SHC kW	CPI	TC kW	SHC kW	CPI	TC kW	SHC kW	CPI
16.0	22	14.1	9.54	1.00	13.6	9.30	1.10	13.1	9.12	1.20	12.6	8.78	1.31
18.0	25	14.7	9.50	1.00	14.2	9.32	1.10	13.7	9.09	1.21	13.2	8.83	1.32
19.0	27	15.0	9.52	1.01	14.5	9.34	1.11	14.0	9.06	1.21	13.5	8.87	1.32
19.5	27	15.2	9.52	1.01	14.7	9.26	1.12	14.2	9.08	1.21	13.6	8.81	1.32
22.0	30	16.0	9.39	1.01	15.5	9.14	1.12	14.9	8.95	1.23	14.4	8.74	1.33
24.0	32	16.7	9.31	1.02	16.1	9.09	1.13	15.5	8.83	1.24	15.0	8.63	1.34

NOTES

- Ratings shown are net capacities which include a deduction for indoor fan motor heat.
- On the figure the mark with ○ show the max. at standard conditions. On the figure the mark with □ show the rated capacity and rated coefficient of power input. However the max. capacity is not guaranteed, except at standard condition.
- SHC is based on indoor EWB and EDB. SHC for other dry bulb temp. = SHC + SHC*. SHC* = SHC correction for other dry bulb. = 0.02 x AFR (m³/min.) x (1-BF) x (DB*-EDB).
- Capacities are based on the following conditions:
Outdoor air: 85% RH.
However, the condition rated capacity in heating is 7° CDB / 6° CWB.
Corresponding refrigerant piping length: 5.0 m.
Level difference: 0 m.
- Coefficient of power input is the percentage when the rated value is defined as 1.00.
- The value contains less than 5% error according to indoor unit type.
- Heating performance include the drop of frost formation.
- Air flow rate and (BF) are given in table below:

(Pair)

	FCQHG125F	FCQG125F	FBQ125C	FHQG125C	FUQ125BW	FDQ125C	FVQ125C	FHQ125CA	FUQ125C
AFR	33.5	33.0	39.0	31.0	32.0	39.0	28.0	31.0	32.5
(BF)	(0.19)	(0.21)	(0.16)	(0.134)	(0.07)	(0.16)	(0.16)	(0.14)	(0.19)

(Triple)

	FCQG50Fx3	FFQ50B9x3	FBQ50Cx3	FHQ50B9Wx3	FHQ50CAx3
AFR	12.6x3	12x3	16x3	13x3	15x3
(BF)	(0.22x3)	(0.16x3)	(0.16x3)	(0.10x3)	(0.18x3)

- Rated power input of each model is given in tables below:

(Pair)

	FCQHG125F	FCQG125F	FBQ125C	FHQG125C	FUQ125BW	FDQ125C	FVQ125C	FHQ125CA	FUQ125C
Cooling	3.00	3.22	3.15	3.58	3.54	3.20	3.74	3.58	3.44

(Triple)

	FCQG50Fx3	FFQ50B9x3	FBQ50Cx3	FHQ50B9Wx3	FHQ50CAx3
Cooling	3.17	3.41	3.28	3.72	3.66

SYMBOLS

- AFR: Air flow rate (m³/min)
 BF: Bypass factor
 EWB: Entering wet bulb temp. (°CWB)
 EDB: Entering dry bulb temp. (°CDB)
 TC: Maximum Total cooling (heating) capacity (kW)
 SHC: Sensible heat capacity (kW)
 PI: Power input (comp.+indoor and outdoor fan motor)
 CPI: Coefficient of power input. (-)

Caution:
TC and SHC are shown by kW.

(Twin)

	FCQG60Fx2	FFQ60B9x2	FBQ60Cx2	FHQ60B9Wx2	FHQ60CAx2
AFR	13.6x2	15x2	18x2	17x2	19.5x2
(BF)	(0.2x2)	(0.11x2)	(0.15x2)	(0.20x2)	(0.20x2)

(Double twin)

	FCQG35Fx4	FFQ35B9x4	FBQ35Cx4	FHQ35B9Wx4	FHQ35CAx4
AFR	12.5x4	10x4	16x4	13x4	14x4
(BF)	(0.4x4)	(0.25x4)	(0.15x4)	(0.20x4)	(0.17x4)

(Twin)

	FCQG60Fx2	FFQ60B9x2	FBQ60Cx2	FHQ60B9Wx2	FHQ60CAx2
Cooling	3.14	3.41	3.28	3.72	3.67

(Double twin)

	FCQG35Fx4	FFQ35B9x4	FBQ35Cx4	FHQ35B9Wx4	FHQ35CAx4
Cooling	3.23	3.41	3.28	3.72	3.64

3D07650A

6 Capacity tables

6 - 1 Cooling Capacity Tables

RZQG140L7V1

Cooling

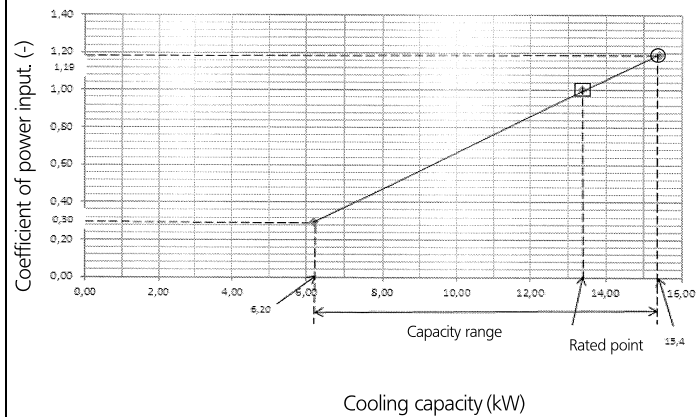

Cooling

Indoor		Outdoor temperature (°CDB)											
		25			30			35			40		
°CWB	°CDB	TC kW	SHC kW	CPI -	TC kW	SHC kW	CPI -	TC kW	SHC kW	CPI -	TC kW	SHC kW	CPI -
16.0	22	15.5	10.47	0.98	14.9	10.25	1.08	14.4	10.08	1.18	13.9	9.89	1.28
18.0	25	16.2	10.55	0.98	15.6	10.21	1.09	15.1	10.01	1.19	14.5	9.71	1.30
19.0	27	16.6	10.43	0.99	16.0	10.18	1.09	15.4	9.98	1.19	14.8	9.76	1.30
19.5	27	16.7	10.49	0.99	16.1	10.16	1.10	15.6	10.00	1.19	15.0	9.66	1.30
22.0	30	17.6	10.37	0.99	17.0	10.16	1.10	16.4	9.83	1.21	15.8	9.60	1.31
24.0	32	18.4	10.20	1.00	17.7	10.00	1.11	17.0	9.67	1.22	16.4	9.47	1.32

NOTES

- Ratings shown are net capacities which include a deduction for indoor fan motor heat.
- On the figure the mark with ○ show the max. at standard conditions.
On the figure the mark with □ show the rated capacity and rated coefficient of power input.
However the max. capacity is not guaranteed, except at standard condition.
- SHC is based on indoor EWB and EDB.
SHC for other dry bulb temp. = SHC + SHC*.
SHC* = SHC correction for other dry bulb.
= 0.02 x AFR (m³/min.) x (1-BF) x (DB* - EDB).
- Capacities are based on the following conditions:
Outdoor air: 85% RH.
However, the condition rated capacity in heating is 7° CDB / 6° CWB.
Corresponding refrigerant piping length: 5.0 m.
Level difference: 0 m.
- Coefficient of power input is the percentage when the rated value is defined as 1.00.
- The value contains less than 5% error according to indoor unit type.
- Heating performance include the drop of frost formation.
- Air flow rate and (BF) are given in table below:

SYMBOLS

- AFR: Air flow rate (m³/min)
- BF: Bypass factor
- EWB: Entering wet bulb temp. (°CWB)
- EDB: Entering dry bulb temp. (°CDB)
- TC: Maximum Total cooling (heating) capacity (kW)
- SHC: Sensible heat capacity (kW)
- PI: Power input
- (comp.+indoor and outdoor fan motor)
- CPI: Coefficient of power input. (-)

Caution:
TC and SHC are shown by kW.

(Pair)

	FCQG140F	FCQG140F	FBQ140C	FHQG140C	FVQ140C	FHQ140CA
AFR (BF)	33.5 (0.15)	33 (0.23)	39 (0.14)	34 (0.17)	30 (0.18)	34 (0.17)

(Twin)

	FCQH71Fx2	FCQG71Fx2	FBQ71Cx2	FHQG71Cx2	FAQ71Cx2	FUQ71BwX2	FHQ71CAx2	FUQ71Cx2
AFR (BF)	21.2x2 (0.2x2)	21.5x2 (0.14x2)	18x2 (0.08x2)	20.5x2 (0.13x2)	18x2 (0.16x2)	19x2 (0.07x2)	20.5x2 (0.13x2)	23x2 (0.24x2)

(Triple)

	FCQG50Fx3	FFQ50B9x3	FBQ50Cx3	FHQ50BwX3	FHQ50CAx3
AFR (BF)	12.6x3 (0.22x3)	12x3 (0.16x3)	16x3 (0.16x3)	13x3 (0.10x3)	15x3 (0.18x3)

(Double twin)

	FCQG35Fx4	FFQ35B9x4	FBQ35Cx4	FHQ35BwX4	FHQ35CAx4
AFR (BF)	12.5x4 (0.4x4)	10x4 (0.25x4)	16x4 (0.15x4)	13x4 (0.20x4)	14x4 (0.20x4)

9. Rated power input of each model is given in tables below:
(Pair)

	FCQG140F	FCQG140F	FBQ140C	FHQG140C	FVQ140C	FHQ140CA
Cooling	4.00	4.17	4.02	4.05	4.17	4.05

(Twin)

	FCQH71Fx2	FCQG71Fx2	FBQ71Cx2	FHQG71Cx2	FAQ71Cx2	FUQ71BwX2	FHQ71CAx2	FUQ71Cx2
Cooling	3.94	4.11	3.75	3.59	3.81	3.49	3.59	3.35

(Triple)

	FCQG50Fx3	FFQ50B9x3	FBQ50Cx3	FHQ50BwX3	FHQ50CAx3
Cooling	4.12	4.20	3.75	4.31	4.25

(Double twin)

	FCQG35Fx4	FFQ35B9x4	FBQ35Cx4	FHQ35BwX4	FHQ35CAx4
Cooling	4.18	4.20	3.75	4.31	4.23

3D076751A

6 Capacity tables

6 - 2 Heating Capacity Tables

6

RZQG71L8V1

Heating

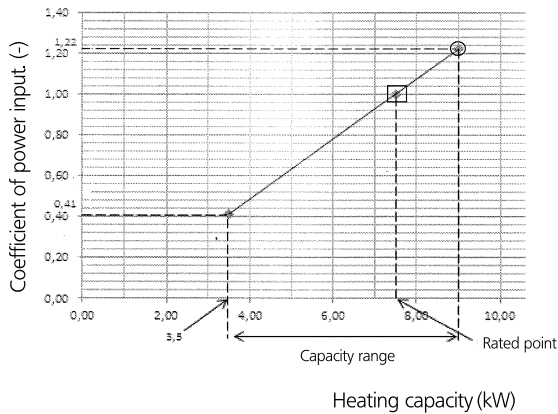

Heating

Indoor °CDB	Outdoor temperature (°CWB)											
	-15.0		-10.0		-5.0		0.0		6.0		10.0	
	TC kW	CPI	TC kW	CPI	TC kW	CPI	TC kW	CPI	TC kW	CPI	TC kW	CPI
16	6.44	0.93	7.09	0.99	7.55	1.02	7.79	1.06	9.00	1.12	9.71	1.19
18	6.43	0.98	7.08	1.03	7.54	1.07	7.78	1.10	9.00	1.17	9.71	1.24
20	6.42	1.01	7.07	1.07	7.53	1.12	7.77	1.14	9.00	1.22	9.71	1.28
21	6.42	1.03	7.07	1.09	7.53	1.13	7.77	1.16	9.00	1.24	9.71	1.31
22	6.42	1.05	7.06	1.11	7.52	1.15	7.76	1.19	9.00	1.27	9.71	1.33
24	6.41	1.09	7.05	1.15	7.51	1.20	7.75	1.23	9.00	1.32	9.67	1.38

NOTES

- Ratings shown are net capacities which include a deduction for indoor fan motor heat.
- On the figure the mark with ○ show the max. at standard conditions.
On the figure the mark with □ show the rated capacity and rated coefficient of power input.
However the max. capacity is not guaranteed, except at standard condition.
- SHC is based on indoor EWB and EDB.
SHC for other dry bulb temp. = SHC + SHC*.
SHC* = SHC correction for other dry bulb.
= 0.02 x AFR (m³/min.) x (1-BF) x (DB*-EDB).
- Capacities are based on the following conditions:
Outdoor air: 85% RH.
However, the condition rated capacity in heating is 7° CDB / 6° CWB.
Corresponding refrigerant piping length: 5.0 m.
Level difference: 0 m.
- Coefficient of power input is the percentage when the rated value is defined as 1.00.
- The value contains less than 5% error according to indoor unit type.
- Heating performance include the drop of frost formation.
- Air flow rate and (BF) are given in table below:

(Pair)

	FCQH71F	FCQG71F	FBQ71C	FHQ71C	FUQ71BW	FAQ71C	PVQ71C	FHQ71CA	FUQ71C
AFR	21.2	21.5	18.0	20.5	19.0	18.0	18.0	20.5	23.0
(BF)	(0.2)	(0.14)	(0.08)	(0.13)	(0.07)	(0.16)	(0.16)	(0.13)	(0.24)

(Twin)

	FCQG35Fx2	FFQ35B9x2	FBQ35Cx2	FHQ35BvWx2	FHQ35CAx2
AFR	12.5x2	10x2	16x2	13x2	14x2
(BF)	(0.4x2)	(0.25x2)	(0.15x2)	(0.20x2)	(0.17x2)

- Rated power input of each model is given in tables below:

(Pair)

	FCQH71F	FCQG71F	FBQ71C	FHQ71C	FUQ71BW	FAQ71C	PVQ71C	FHQ71CA	FUQ71C
Heating	1.56	1.89	2.05	1.82	1.84	2.03	2.06	1.82	1.68

(Twin)

	FCQG35Fx2	FFQ35B9x2	FBQ35Cx2	FHQ35BvWx2	FHQ35CAx2
Heating	1.92	2.61	2.16	2.78	2.70

SYMBOLS

- AFR: Air flow rate (m³/min)
 BF: Bypass factor
 EWB: Entering wet bulb temp. (°CWB)
 EDB: Entering dry bulb temp. (°CDB)
 TC: Maximum Total cooling (heating) capacity (kW)
 SHC: Sensible heat capacity (kW)
 PI: Power input
 (comp.+indoor and outdoor fan motor)
 CPI: Coefficient of power input. (-)

Caution:
TC and SHC are shown by kW.

3D076748A

6 Capacity tables

6 - 2 Heating Capacity Tables

RZQG100L8V1

Heating

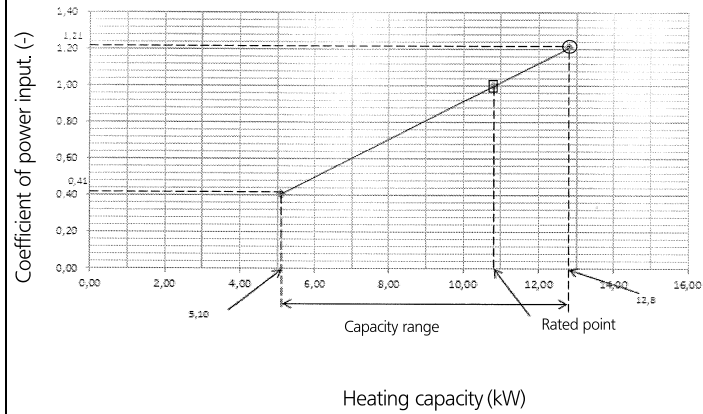

Heating

Indoor °CDB	Outdoor temperature (°CWB)											
	-15.0		-10.0		-5.0		0.0		6.0		10.0	
	TC kW	CPI	TC kW	CPI	TC kW	CPI	TC kW	CPI	TC kW	CPI	TC kW	CPI
16	8.58	0.92	9.45	0.98	10.1	1.02	10.4	1.05	12.8	1.11	13.8	1.18
18	8.57	0.97	9.44	1.02	10.0	1.06	10.3	1.09	12.8	1.16	13.8	1.23
20	8.56	1.00	9.43	1.06	10.0	1.11	10.3	1.13	12.8	1.21	13.8	1.27
21	8.56	1.02	9.42	1.08	10.0	1.12	10.3	1.15	12.8	1.23	13.8	1.30
22	8.55	1.04	9.42	1.10	10.0	1.14	10.3	1.18	12.8	1.26	13.8	1.32
24	8.54	1.08	9.41	1.14	10.0	1.19	10.3	1.22	12.8	1.31	13.8	1.37

NOTES

- Ratings shown are net capacities which include a deduction for indoor fan motor heat.
- On the figure the mark with ○ show the max. at standard conditions.
On the figure the mark with □ show the rated capacity and rated coefficient of power input.
However the max. capacity is not guaranteed, except at standard condition.
- SHC is based on indoor EWB and EDB.
SHC for other dry bulb temp. = SHC + SHC*.
SHC* = SHC correction for other dry bulb.
= 0.02 × AFR (m³/min.) × (1-BF) × (DB*-EDB).
- Capacities are based on the following conditions:
Outdoor air: 85% RH.
However, the condition rated capacity in heating is 7° CDB / 6° CWB.
Corresponding refrigerant piping length: 5.0 m.
Level difference: 0 m.
- Coefficient of power input is the percentage when the rated value is defined as 1.00.
- The value contains less than 5% error according to indoor unit type.
- Heating performance include the drop of frost formation.
- Air flow rate and (BF) are given in table below:

(Pair)

	FCQH100F	FCQG100F	FBQ100C	FHQG100C	FUQ100BW	FAQ100C	FVQ100C	FHQ100CA	FUQ100C
AFR	32.3	32.0	32.0	20.0	29.0	26.0	28.0	28.0	31.0
(BF)	(0.17)	(0.17)	(0.13)	(0.09)	(0.07)	(0.10)	(0.20)	(0.09)	(0.20)

(Triple)

	FCQG35F3	FFQ35B9x3	FBQ35C3	FHQ35BWx3	FHQ35CAx3
AFR	12.5x3	10x3	16x3	13x3	14x3
(BF)	(0.4x3)	(0.25x3)	(0.15x3)	(0.20x3)	(0.17x3)

- Rated power input of each model is given in tables below:

(Pair)

	FCQH100F	FCQG100F	FBQ100C	FHQG100C	FUQ100BW	FAQ100C	FVQ100C	FHQ100CA	FUQ100C
Heating	2.16	2.60	2.57	2.60	2.73	3.00	2.61	2.60	2.62

(Triple)

	FCQG35F3	FFQ35B9x3	FBQ35C3	FHQ35BWx3	FHQ35CAx3
Heating	2.51	2.79	2.86	3.32	3.20

SYMBOLS

- AFR: Air flow rate (m³/min)
 BF: Bypass factor
 EWB: Entering wet bulb temp.(°CWB)
 EDB: Entering dry bulb temp. (°CDB)
 TC: Maximum Total cooling (heating) capacity (kW)
 SHC: Sensible heat capacity (kW)
 PI: Power input
 (comp.+indoor and outdoor fan motor)
 CPI: Coefficient of power input. (-)

Caution:
TC and SHC are shown by kW.

(Twin)

	FCQG50F2	FFQ50B9x2	FBQ50C2	FHQ50BWx2	FHQ50CAx2
AFR	12.6x2	12x2	16x2	13x2	15x2
(BF)	(0.22x2)	(0.16x2)	(0.16x2)	(0.10x2)	(0.18x2)

(Twin)

	FCQG50F2	FFQ50B9x2	FBQ50C2	FHQ50BWx2	FHQ50CAx2
Heating	2.46	2.79	2.86	3.32	3.28

3D076749A

6 Capacity tables

6 - 2 Heating Capacity Tables

6

RZQG125L8V1

Heating

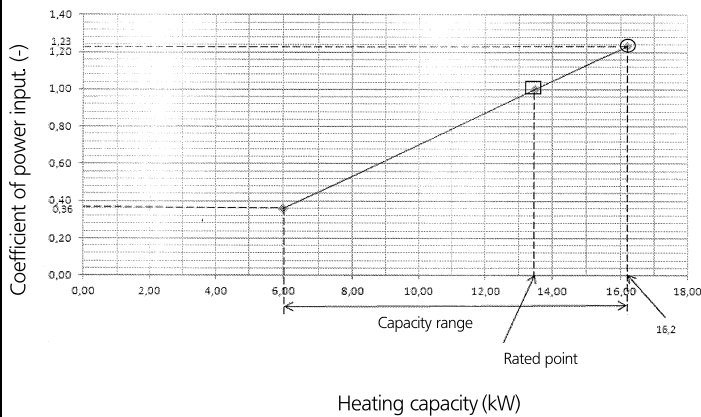

Heating

Indoor °CDB	Outdoor temperature (°CWB)											
	-15.0		-10.0		-5.0		0.0		6.0		10.0	
	TC kW	CPI	TC kW	CPI	TC kW	CPI	TC kW	CPI	TC kW	CPI	TC kW	CPI
16	11.0	0.94	12.1	1.00	12.9	1.03	13.2	1.06	16.2	1.13	17.5	1.20
18	11.0	0.98	12.1	1.03	12.9	1.08	13.2	1.11	16.2	1.18	17.5	1.25
20	11.0	1.02	12.0	1.08	12.9	1.13	13.2	1.15	16.2	1.23	17.5	1.30
21	11.0	1.04	12.0	1.10	12.8	1.14	13.2	1.17	16.2	1.25	17.5	1.32
22	11.0	1.06	12.0	1.12	12.8	1.16	13.2	1.20	16.2	1.28	17.4	1.34
24	11.0	1.10	12.0	1.16	12.8	1.21	13.2	1.24	16.2	1.33	17.4	1.39

NOTES

- Ratings shown are net capacities which include a deduction for indoor fan motor heat.
- On the figure the mark with ○ show the max. at standard conditions.
On the figure the mark with □ show the rated capacity and rated coefficient of power input.
However the max. capacity is not guaranteed, except at standard condition.
- SHC is based on indoor EWB and EDB.
SHC for other dry bulb temp. = SHC + SHC*.
SHC* = SHC correction for other dry bulb.
= 0.02 x AFR (m³/min.) x (1-BF) x (DB* - EDB).
- Capacities are based on the following conditions:
Outdoor air: 85% RH.
However, the condition rated capacity in heating is 7° CDB / 6° CWB.
Corresponding refrigerant piping length: 5.0 m.
Level difference: 0 m.
- Coefficient of power input is the percentage when the rated value is defined as 1.00.
- The value contains less than 5% error according to indoor unit type.
- Heating performance include the drop of frost formation.
- Air flow rate and (BF) are given in table below:

(Pair)

	FCQG125F	FCQG125F	FBQ125C	FHQG125C	FUQ125BW	FDQ125C	FVQ125C	FHQ125CA	FUQ125C
AFR (BF)	33.5 (0.19)	33.0 (0.21)	39.0 (0.16)	31.0 (0.134)	32.0 (0.07)	39.0 (0.16)	28.0 (0.16)	31.0 (0.14)	32.5 (0.19)

(Triple)

	FCQG50Fx3	FFQ50B9x3	FBQ50Cx3	FHQ50B1Wx3	FHQ50CAx3
AFR (BF)	12.6x3 (0.22x3)	12x3 (0.16x3)	16x3 (0.16x3)	13x3 (0.10x3)	15x3 (0.18x3)

- Rated power input of each model is given in tables below:

(Pair)

	FCQG125F	FCQG125F	FBQ125C	FHQG125C	FUQ125BW	FDQ125C	FVQ125C	FHQ125CA	FUQ125C
Heating	3.07	3.72	3.53	3.48	3.95	3.53	3.65	3.48	3.86

(Triple)

	FCQG50Fx3	FFQ50B9x3	FBQ50Cx3	FHQ50B1Wx3	FHQ50CAx3
Heating	3.66	3.83	3.74	4.16	4.10

SYMBOLS

- AFR: Air flow rate (m³/min)
 BF: Bypass factor
 EWB: Entering wet bulb temp. (°CWB)
 EDB: Entering dry bulb temp. (°CDB)
 TC: Maximum Total cooling (heating) capacity (kW)
 SHC: Sensible heat capacity (kW)
 PI: Power input
 (comp.+indoor and outdoor fan motor)
 CPI: Coefficient of power input. (-)

Caution:
 TC and SHC are shown by kW.

(Twin)

	FCQG60Fx2	FFQ60B9x2	FBQ60Cx2	FHQ60B1Wx2	FHQ60CAx2
AFR (BF)	13.6x2 (0.2x2)	15x2 (0.11x2)	18x2 (0.15x2)	17x2 (0.20x2)	19.5x2 (0.20x2)

(Double twin)

	FCQG35Fx4	FFQ35B9x4	FBQ35Cx4	FHQ35B1Wx4	FHQ35CAx4
AFR (BF)	12.5x4 (0.4x4)	10x4 (0.25x4)	16x4 (0.15x4)	13x4 (0.20x4)	14x4 (0.17x4)

(Twin)

	FCQG60Fx2	FFQ60B9x2	FBQ60Cx2	FHQ60B1Wx2	FHQ60CAx2
Heating	3.64	3.83	3.74	4.16	4.11

(Double twin)

	FCQG35Fx4	FFQ35B9x4	FBQ35Cx4	FHQ35B1Wx4	FHQ35CAx4
Heating	3.72	3.83	3.74	4.16	4.00

3D076750A

6 Capacity tables

6 - 2 Heating Capacity Tables

RZQG140L7V1

Heating

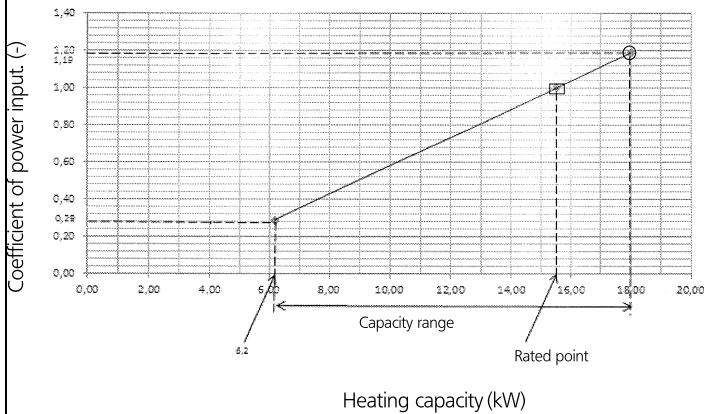

Heating

Indoor °CDB	Outdoor temperature (°CWB)											
	-15.0		-10.0		-5.0		0.0		6.0		10.0	
	TC kW	CPI	TC kW	CPI	TC kW	CPI	TC kW	CPI	TC kW	CPI	TC kW	CPI
16	11.6	0.91	12.7	0.97	13.6	1.00	13.9	1.03	18.0	1.09	19.4	1.16
18	11.6	0.95	12.7	1.00	13.6	1.04	13.9	1.07	18.0	1.14	19.4	1.21
20	11.6	0.99	12.7	1.05	13.5	1.09	13.9	1.11	18.0	1.19	19.4	1.25
21	11.5	1.00	12.7	1.06	13.5	1.11	13.9	1.13	18.0	1.21	19.4	1.28
22	11.5	1.02	12.7	1.08	13.5	1.12	13.9	1.16	18.0	1.24	19.4	1.30
24	11.5	1.07	12.6	1.12	13.5	1.17	13.9	1.20	18.0	1.29	19.4	1.35

NOTES

- Ratings shown are net capacities which include a deduction for indoor fan motor heat.
- On the figure the mark with ○ show the max. at standard conditions.
On the figure the mark with □ show the rated capacity and rated coefficient of power input.
However the max. capacity is not guaranteed, except at standard condition.
- SHC is based on indoor EWB and EDB.
SHC for other dry bulb temp. = SHC + SHC*
SHC* = SHC correction for other dry bulb.
= 0.02 x AFR (m³/min) x (1-BF) x (DB* - EDB).
- Capacities are based on the following conditions:
Outdoor air: 85% RH.
However, the condition rated capacity in heating is 7° CDB / 6° CWB.
Corresponding refrigerant piping length: 5.0 m.
Level difference: 0 m.
- Coefficient of power input is the percentage when the rated value is defined as 1.00.
- The value contains less than 5% error according to indoor unit type.
- Heating performance include the drop of frost formation.
- Air flow rate and (BF) are given in table below:

SYMBOLS

- AFR: Air flow rate (m³/min)
- BF: Bypass factor
- EWB: Entering wet bulb temp. (°CWB)
- EDB: Entering dry bulb temp. (°CDB)
- TC: Maximum Total cooling (heating) capacity (kW)
- SHC: Sensible heat capacity (kW)
- PI: Power input
- (comp.+indoor and outdoor fan motor)
- CPI: Coefficient of power input. (-)

Caution:
TC and SHC are shown by kW.

(Pair)

	FCQH140F	FCQ140F	FBQ140C	FHQ140C	FVQ140C	FHQ140CA
AFR	33.5	33	41	34	30	34
(BF)	(0.15)	(0.23)	(0.14)	(0.17)	(0.18)	(0.17)

(Twin)

	FCQH140F2	FCQ140F2	FBQ140C2	FHQ140C2	FAQ140C2	FUQ140W2	FHQ140CA2	FUQ140C2
AFR	21.2x2	21.5x2	18x2	20.5x2	18x2	19x2	20.5x2	23x2
(BF)	(0.2x2)	(0.14x2)	(0.08x2)	(0.13x2)	(0.16x2)	(0.07x2)	(0.13x2)	(0.24x2)

(Triple)

	FCQ50F3	FFQ50B9x3	FBQ50C3	FHQ50Bw3	FHQ50CAx3
AFR	12.6x3	12x3	16x3	13x3	15x3
(BF)	(0.22x3)	(0.16x3)	(0.16x3)	(0.10x3)	(0.18x3)

(Double twin)

	FCQ35F4	FFQ35B9x4	FBQ35C4	FHQ35Bw4	FHQ35CAx4
AFR	12.5x4	10x4	16x4	13x4	14x4
(BF)	(0.4x4)	(0.25x4)	(0.15x4)	(0.20x4)	(0.20x4)

- Rated power input of each model is given in tables below:

(Pair)

	FCQH140F	FCQ140F	FBQ140C	FHQ140C	FVQ140C	FHQ140CA
Heating	3.77	4.30	4.30	4.27	4.30	4.27

(Twin)

	FCQH140F2	FCQ140F2	FBQ140C2	FHQ140C2	FAQ140C2	FUQ140W2	FHQ140CA2	FUQ140C2
Heating	3.71	4.24	4.70	4.47	4.68	4.47	4.47	4.36

(Triple)

	FCQ50F3	FFQ50B9x3	FBQ50C3	FHQ50Bw3	FHQ50CAx3
Heating	4.24	4.92	4.70	5.49	5.43

(Double twin)

	FCQ35F4	FFQ35B9x4	FBQ35C4	FHQ35Bw4	FHQ35CAx4
Heating	4.30	4.92	4.70	5.49	5.33

3D076751A

6 Capacity tables

6 - 3 Capacity Correction Factor

6

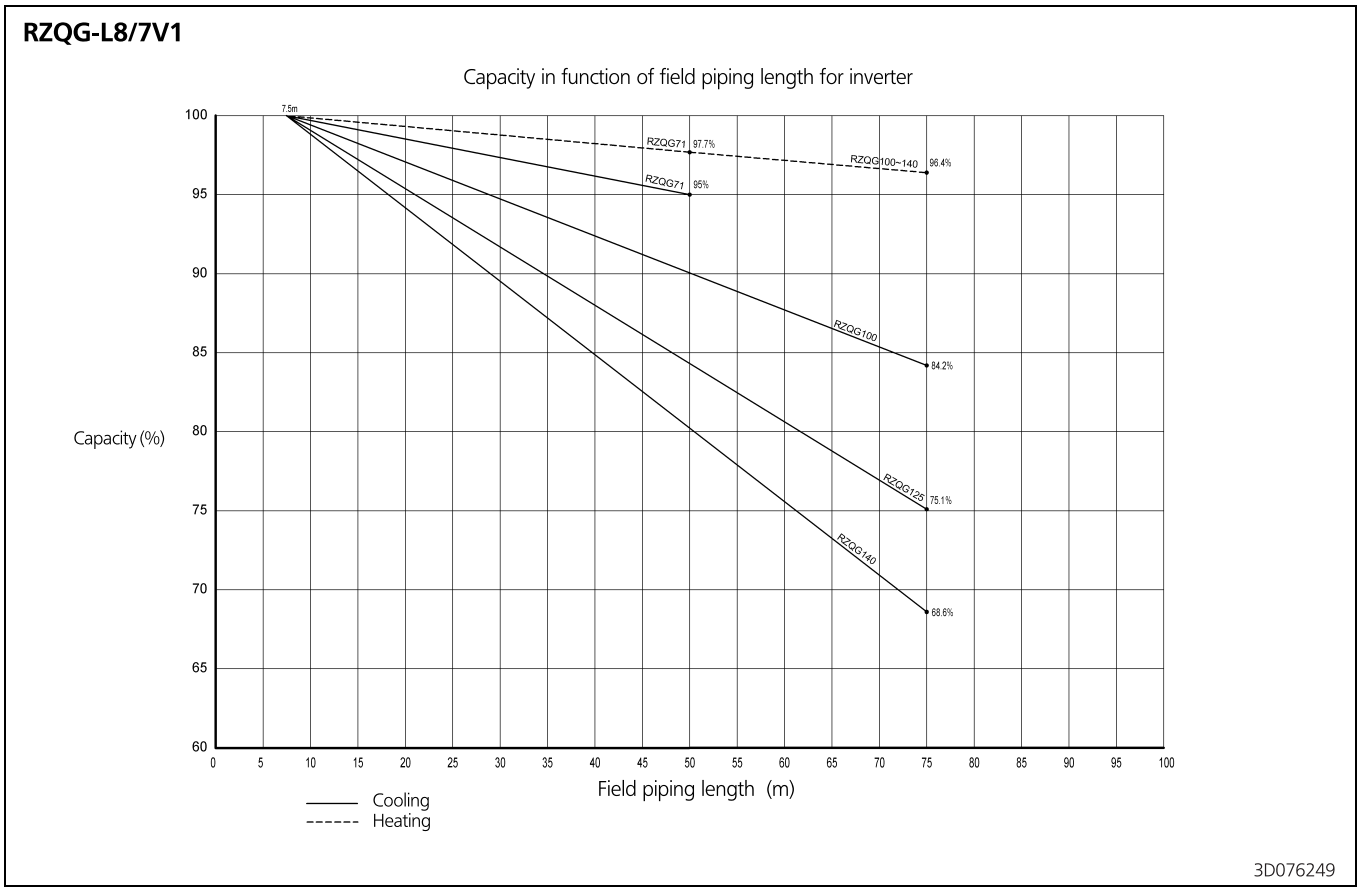

7 Dimensional drawings

7 - 1 Dimensional Drawings

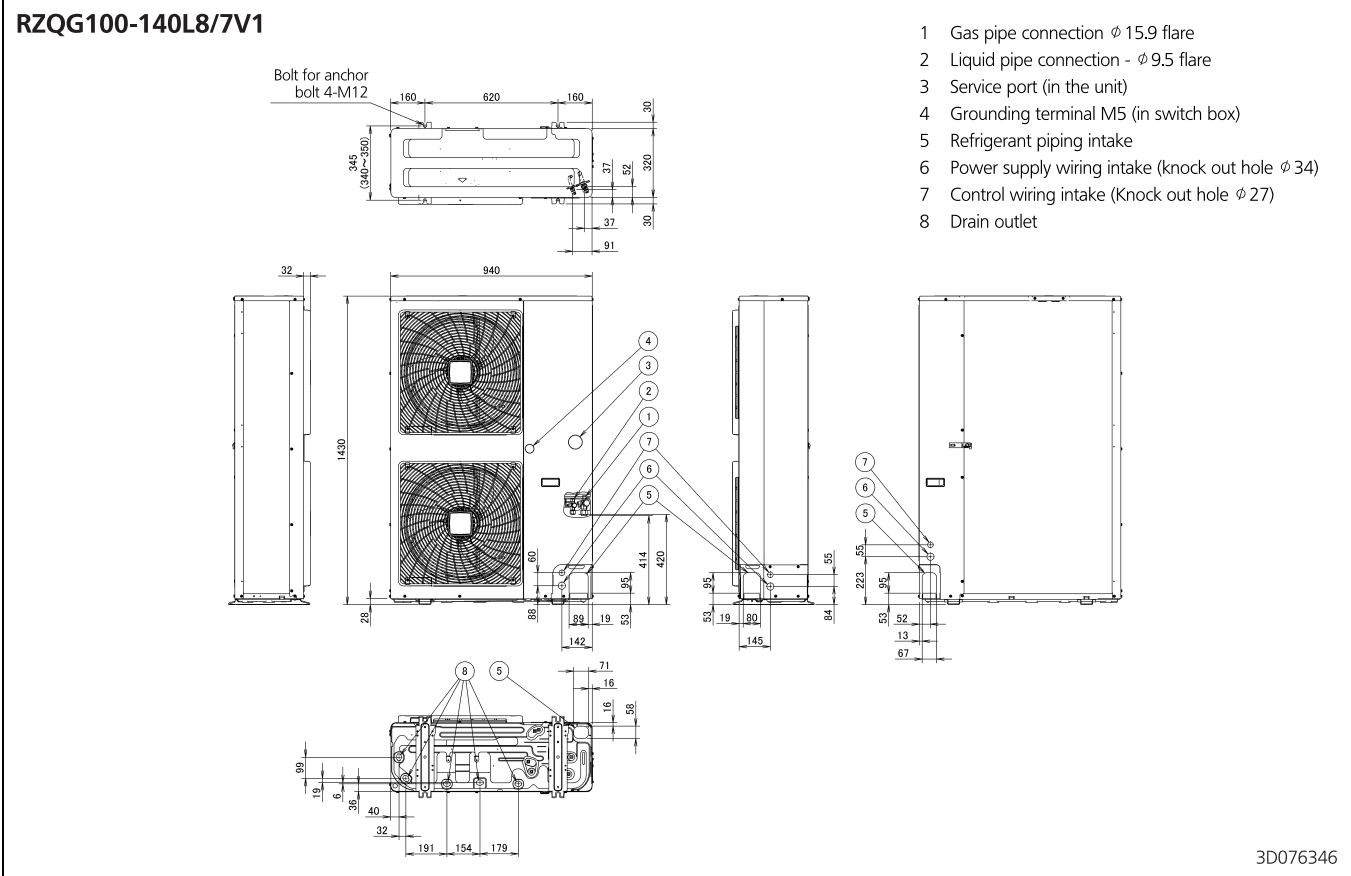
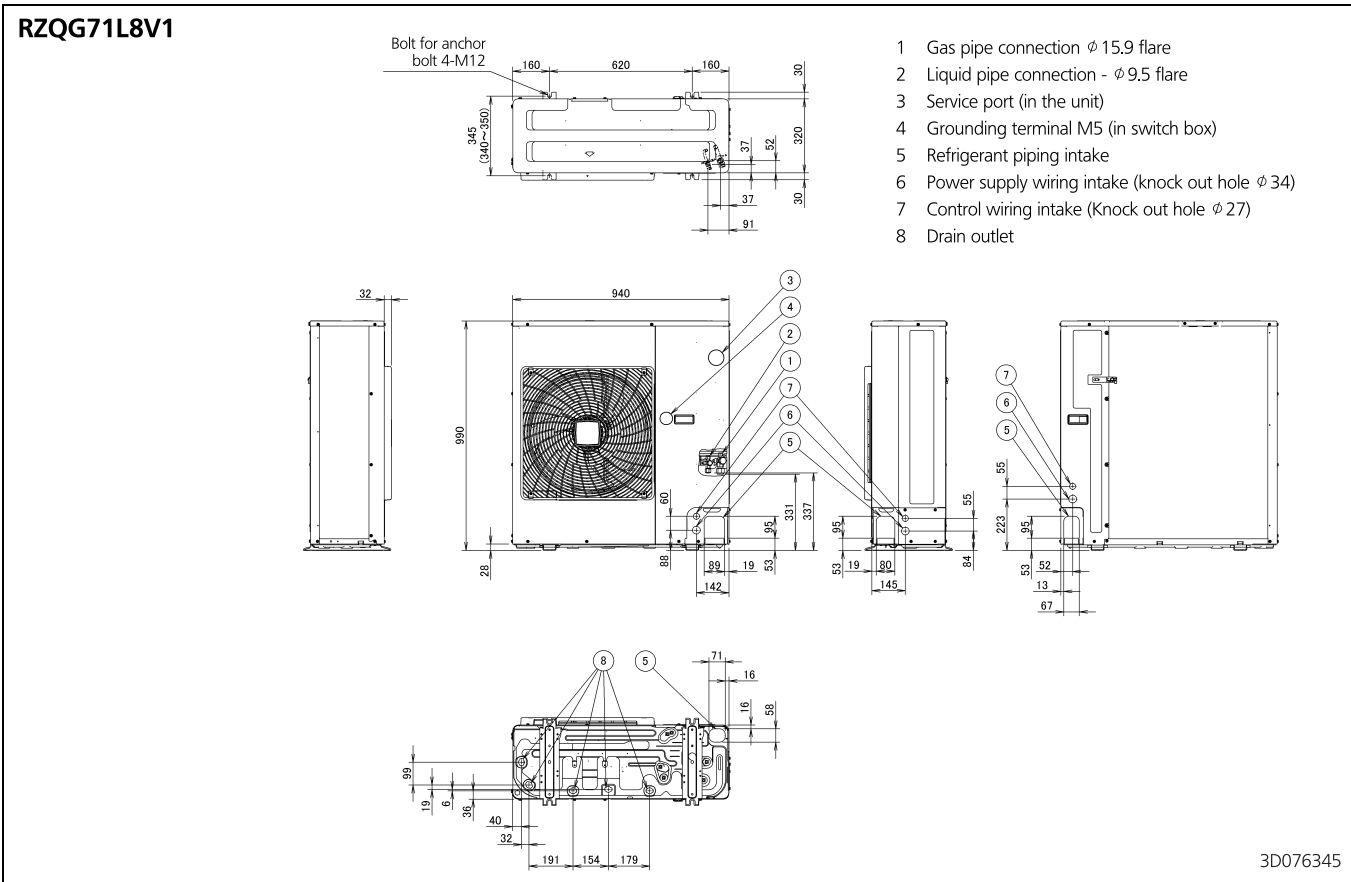

8 Centre of gravity

8 - 1 Centre of Gravity

8

RZQG71L8V1

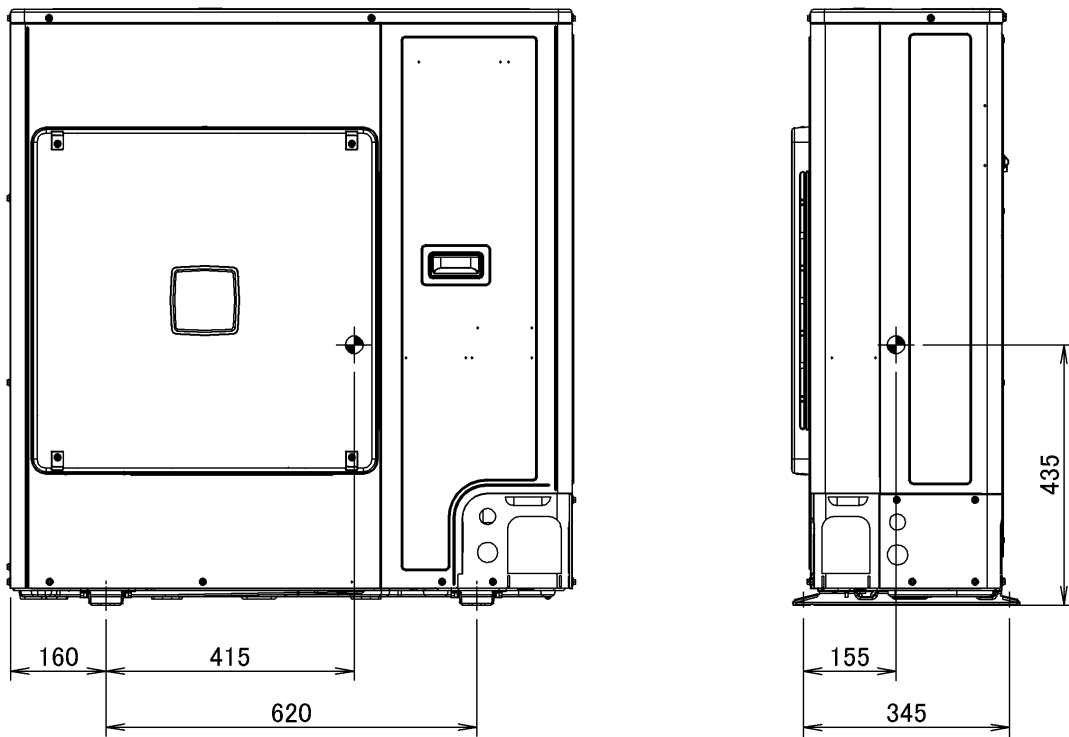

4D076236

RZQG100-140L8/7V1

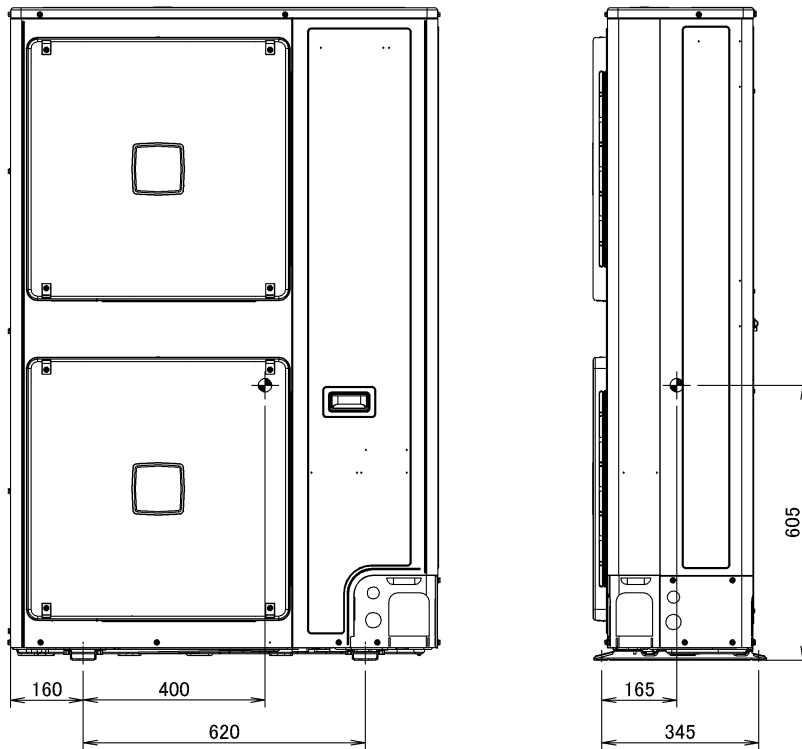

4D076248

9 Piping diagrams

9 - 1 Piping Diagrams

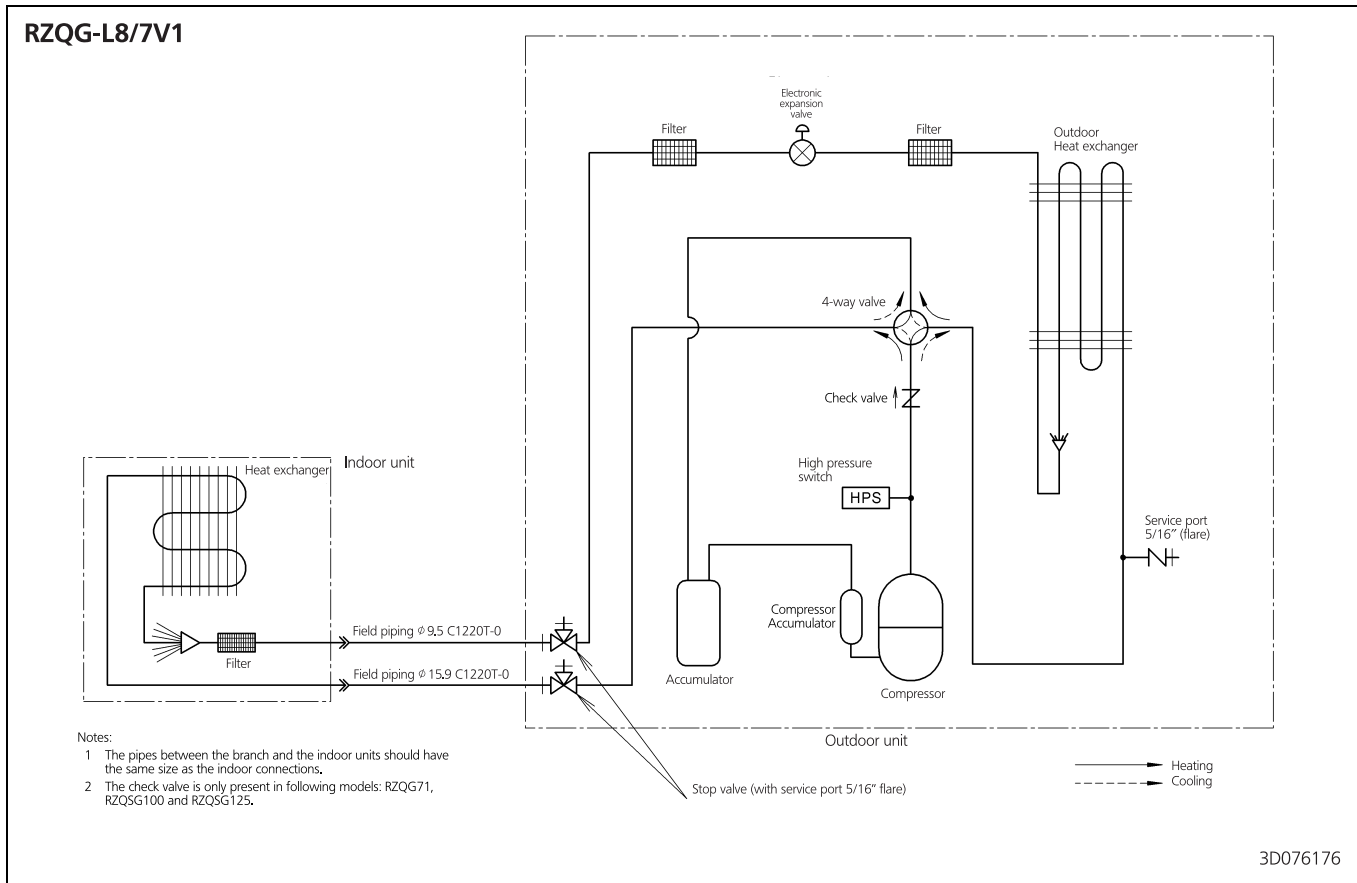

9 Piping diagrams

9 - 2 Piping Diagram Twin Application

9

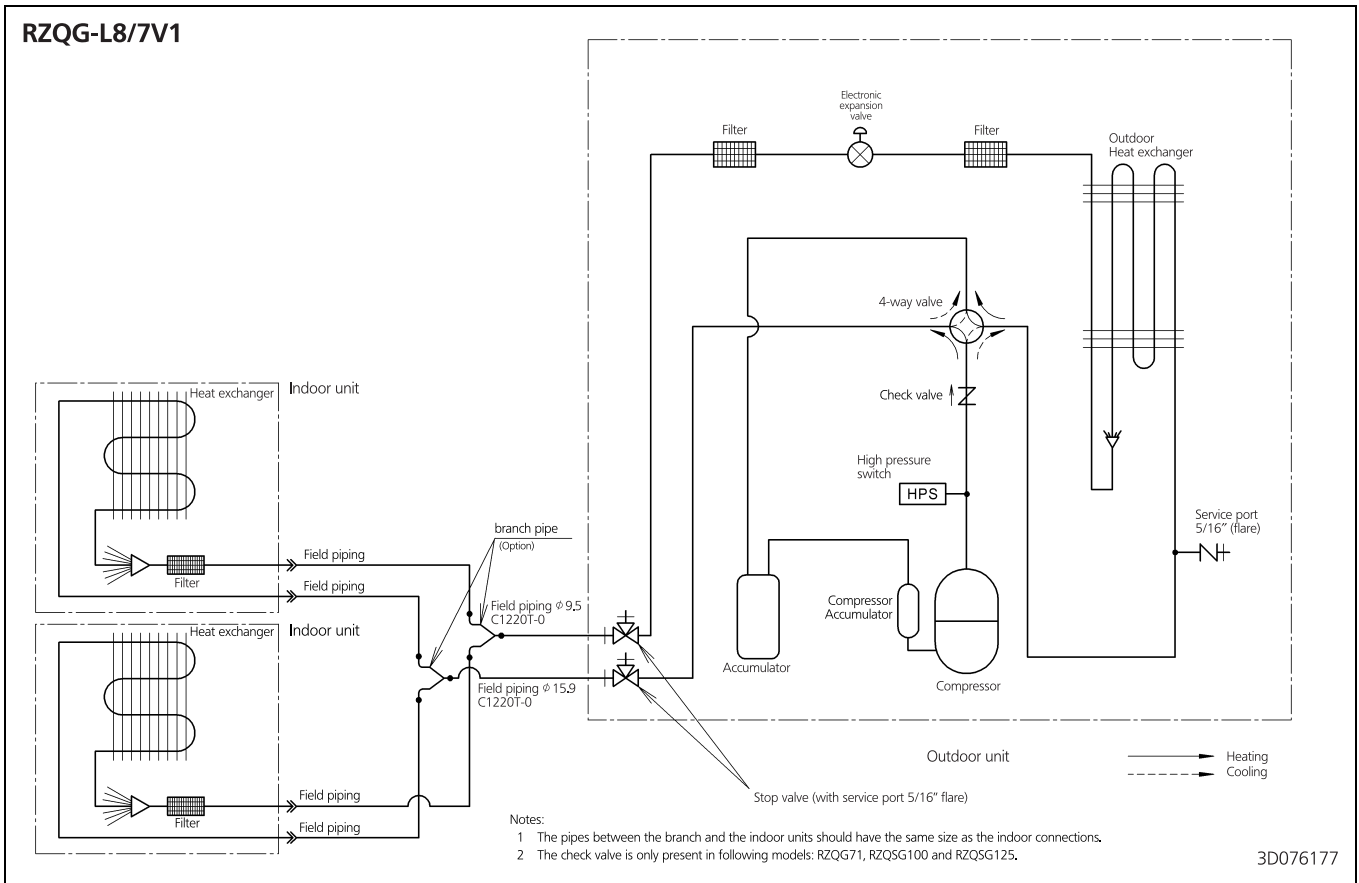

9 Piping diagrams

9 - 3 Piping Diagram Triple Application

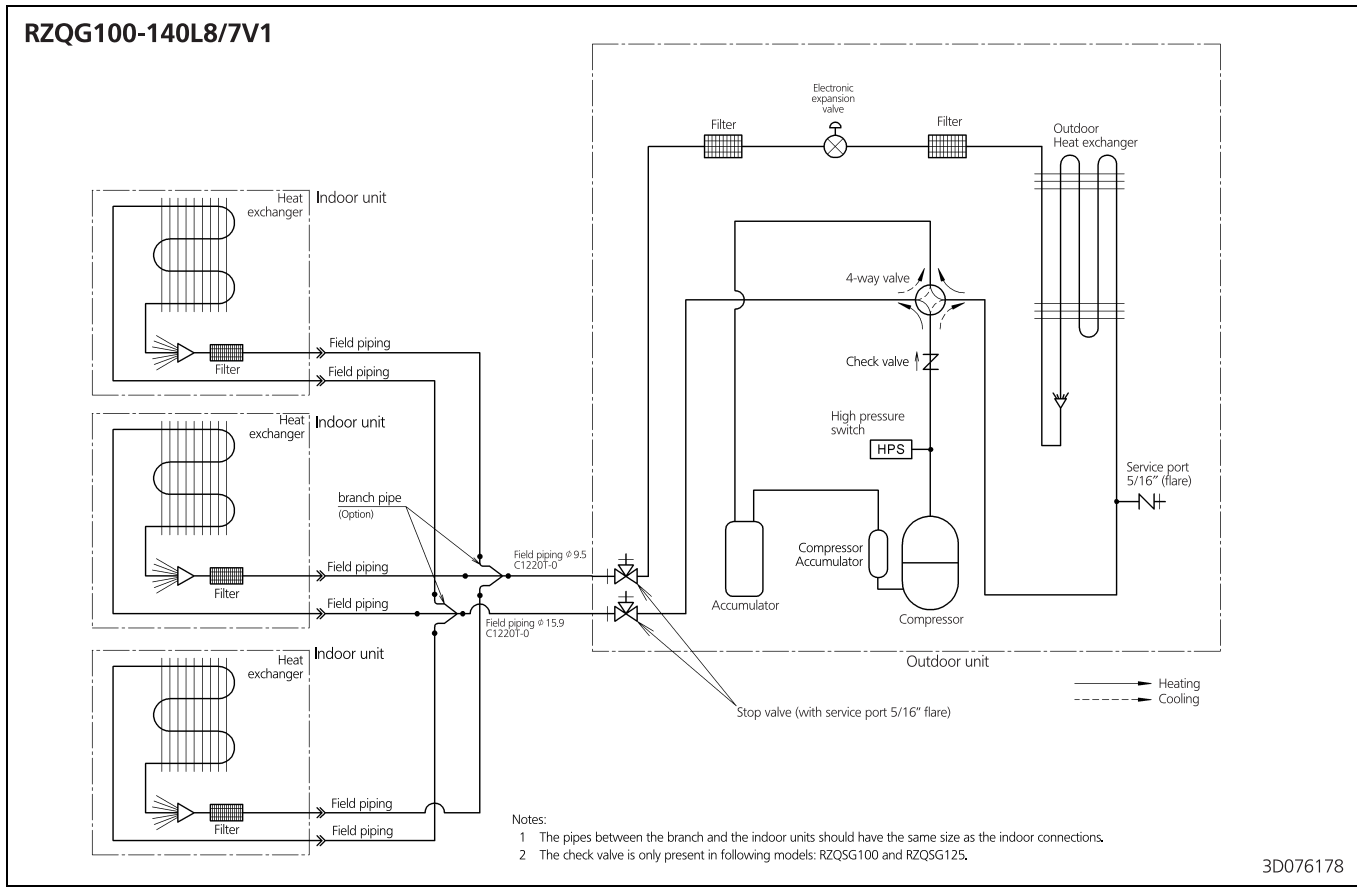

9 Piping diagrams

9 - 4 Piping Diagram Double Twin Application

9

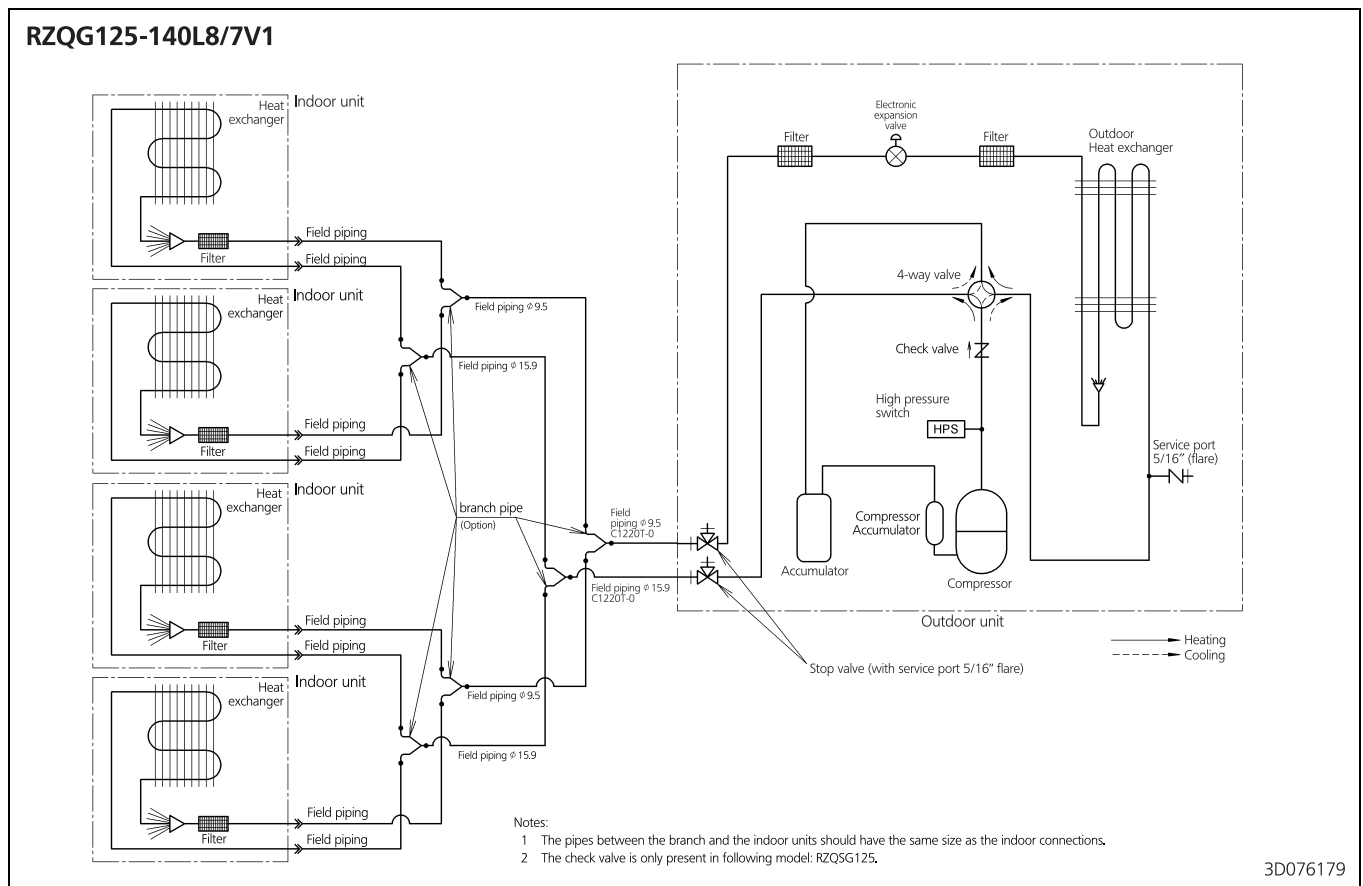

10 Wiring diagrams

10 - 1 Wiring Diagrams - Single Phase

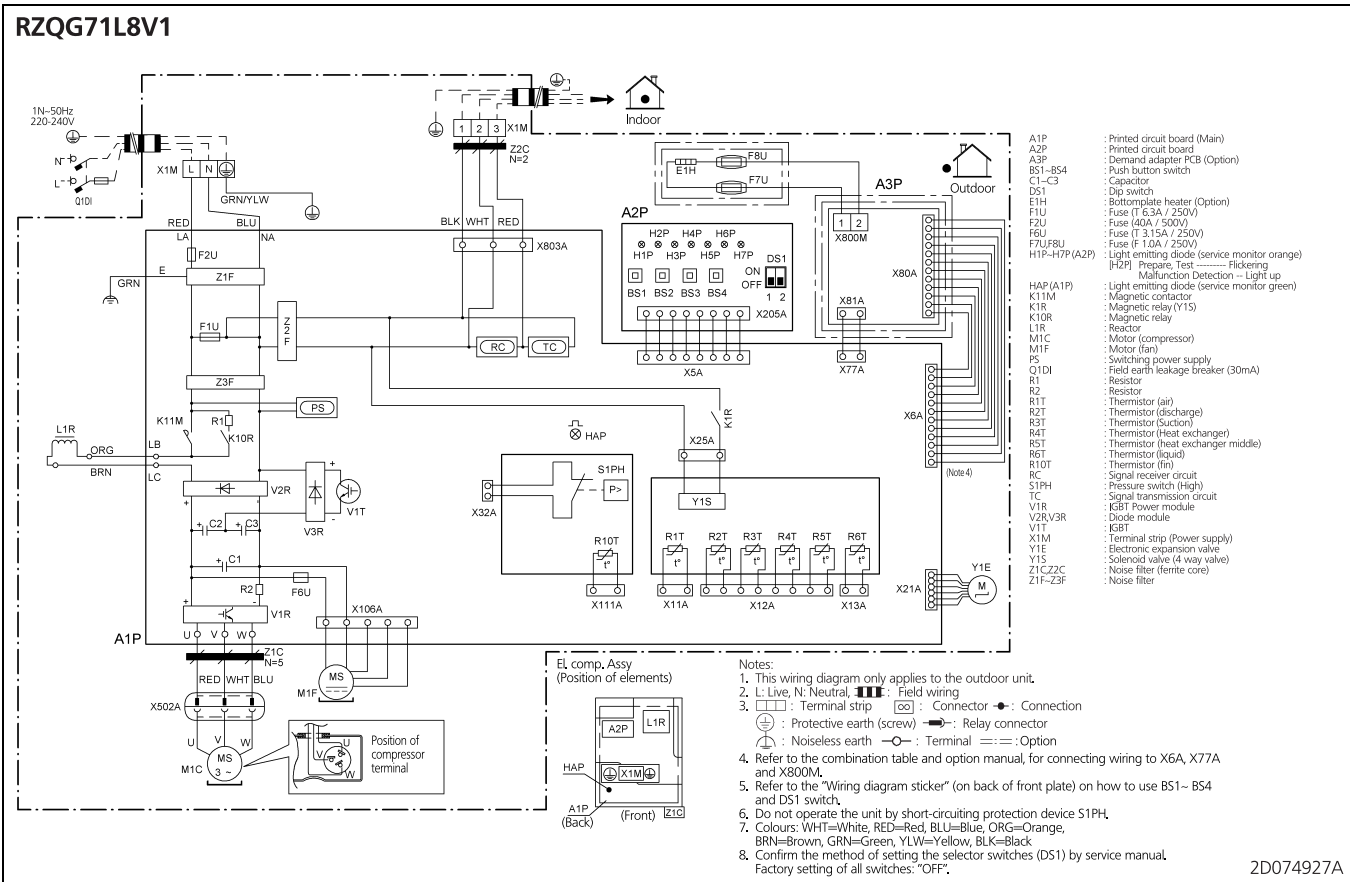

2D074927A

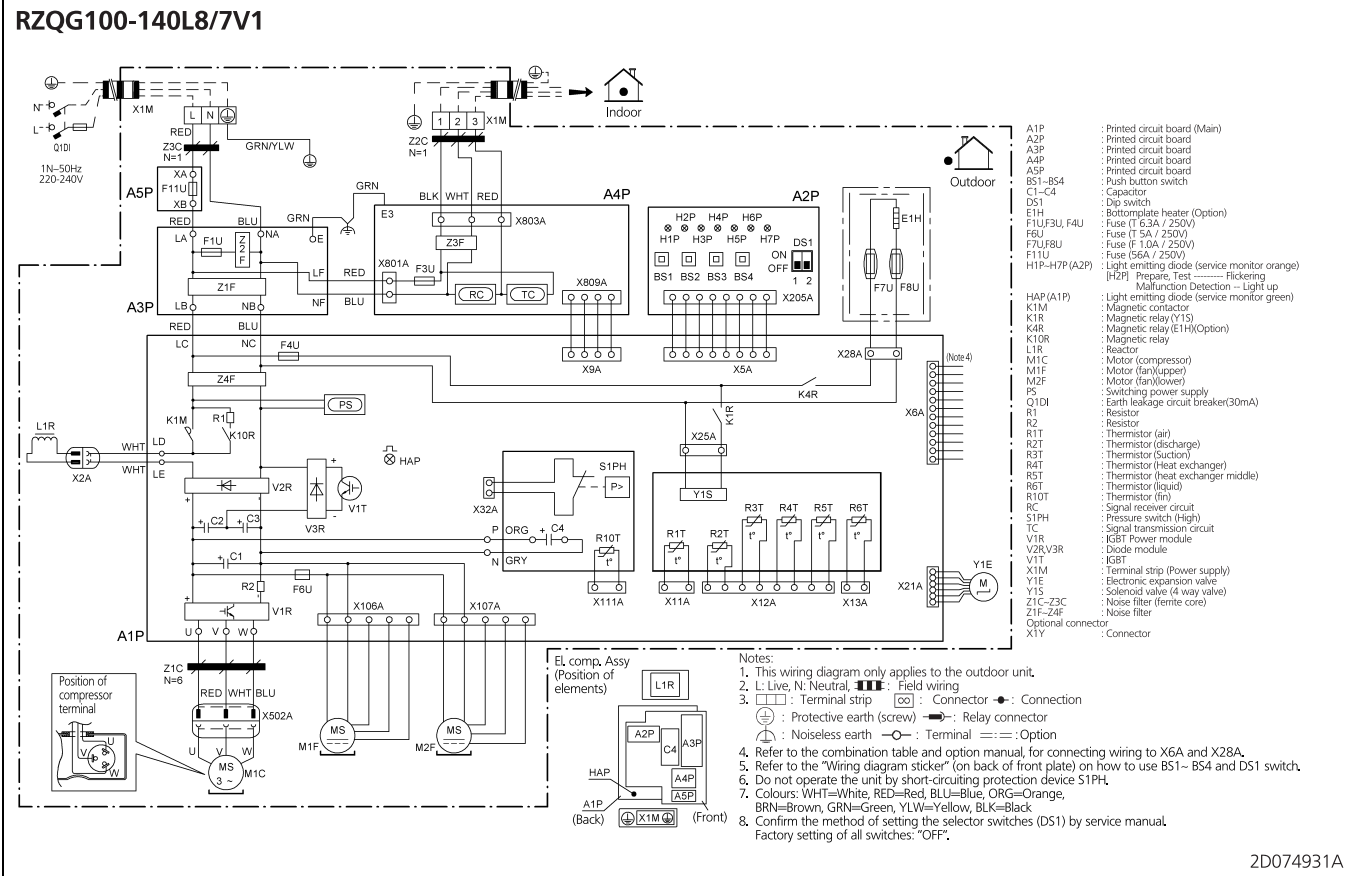

2D074931A

11 Sound data

11 - 1 Sound Power Spectrum

11

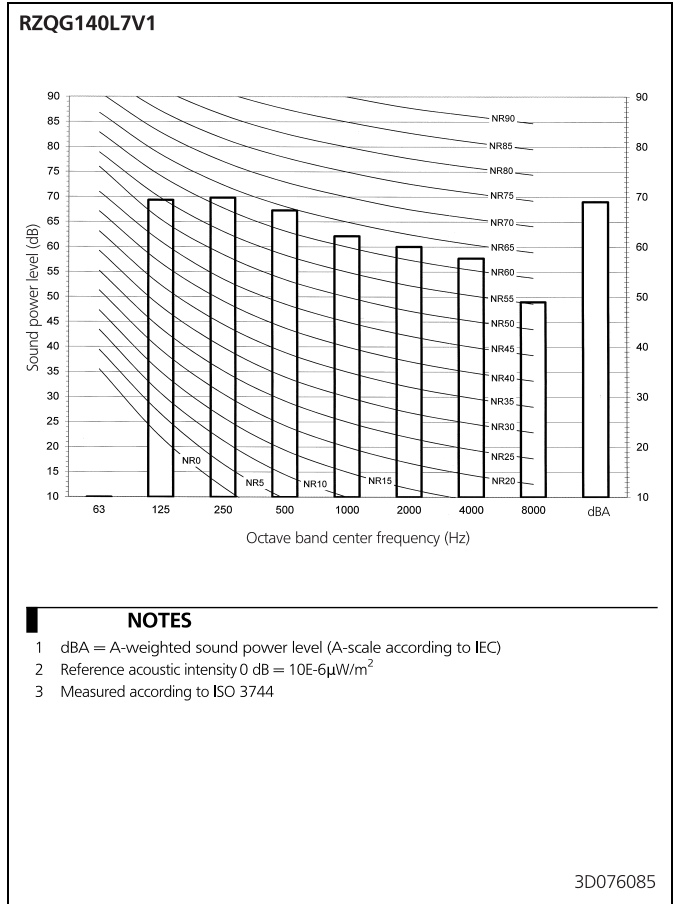
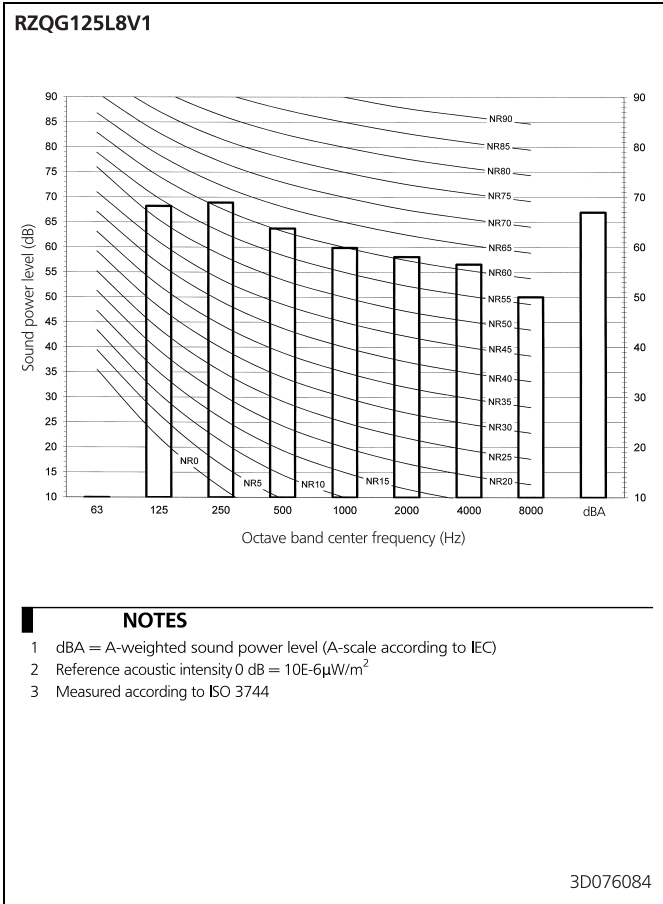
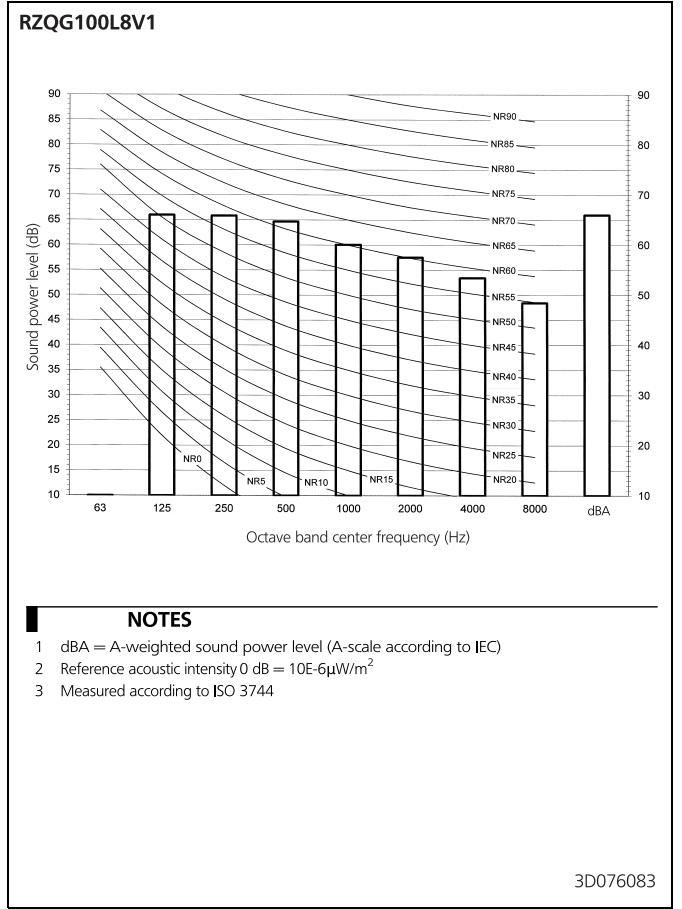
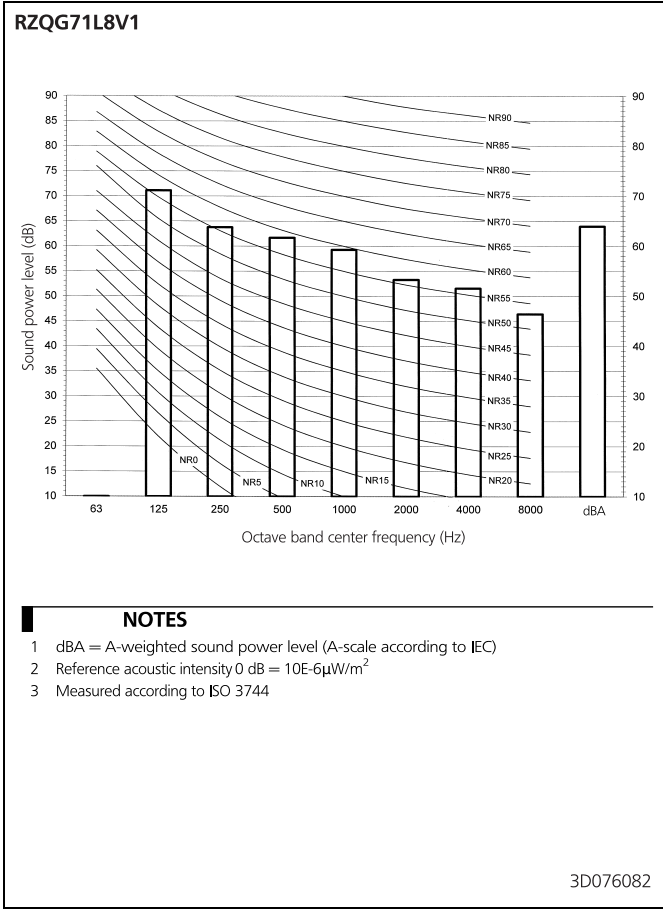

11 Sound data

11 - 2 Sound Pressure Spectrum - Cooling

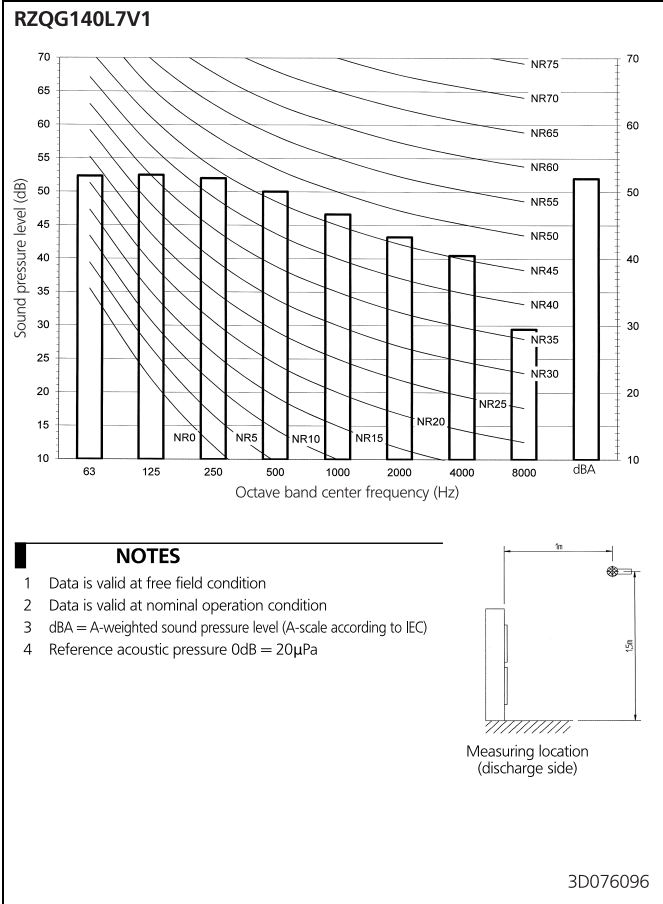
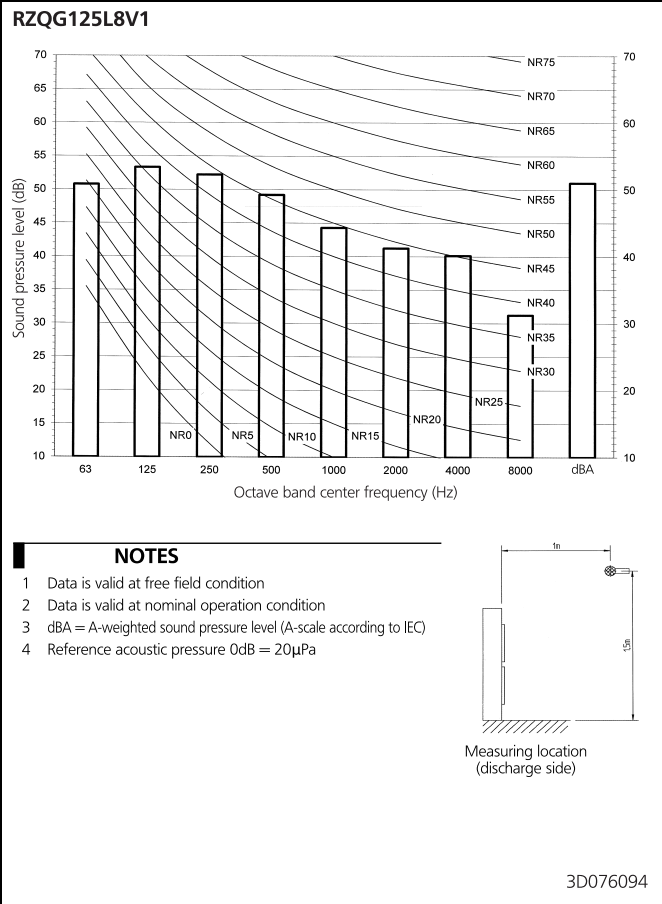
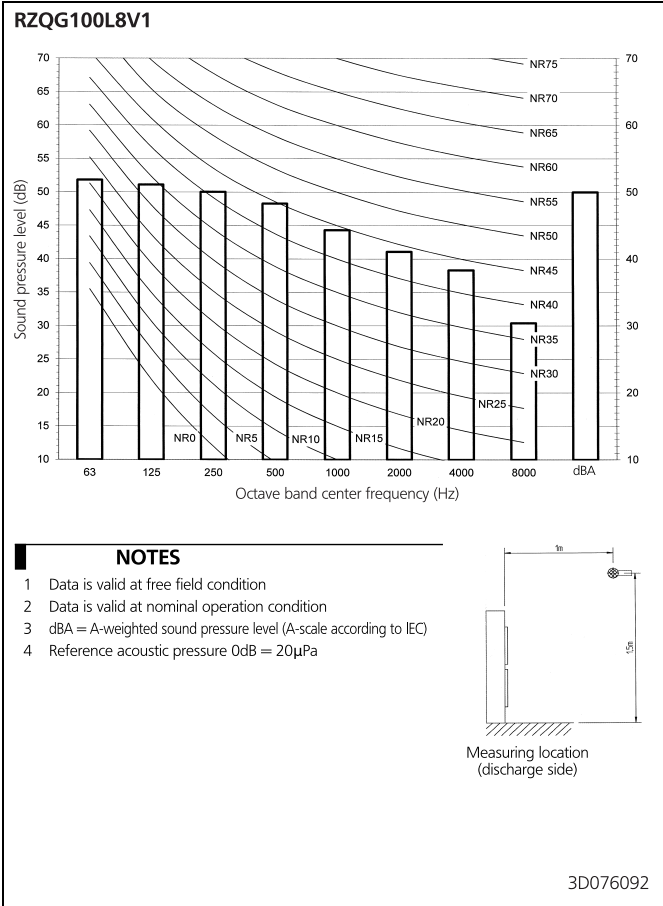
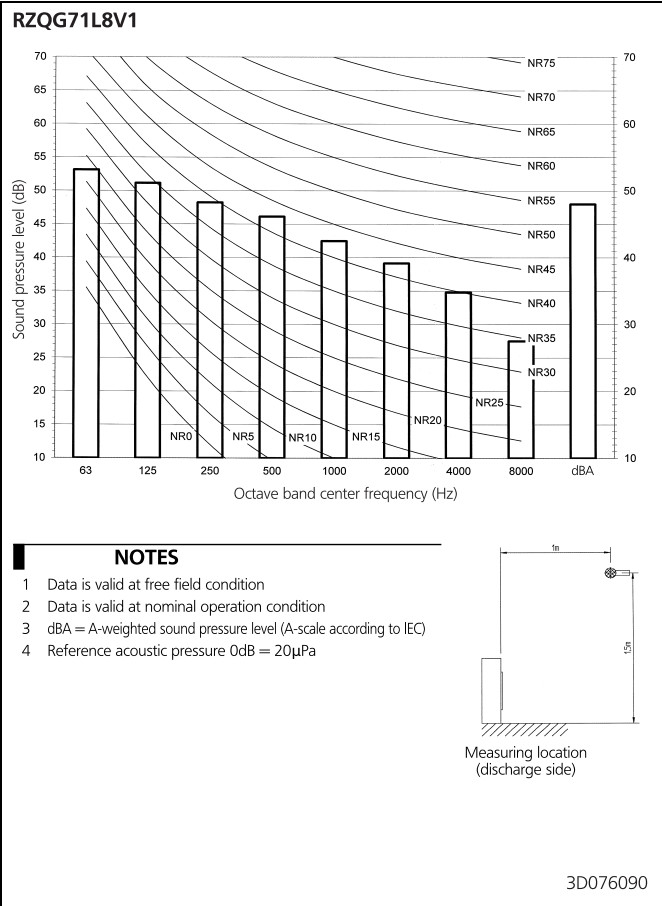

11 Sound data

11 - 3 Sound Pressure Spectrum - Heating

11

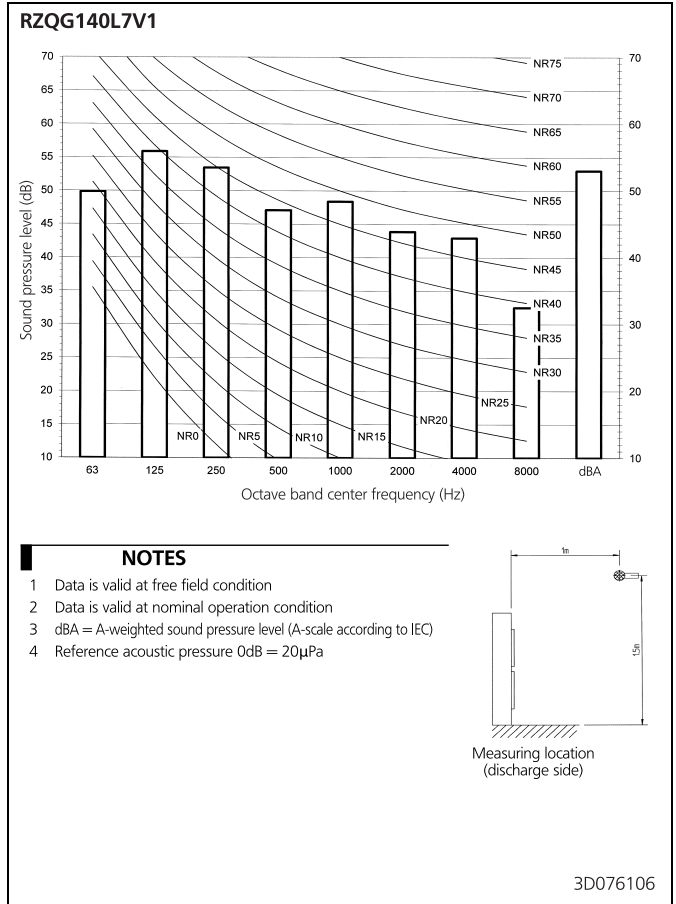
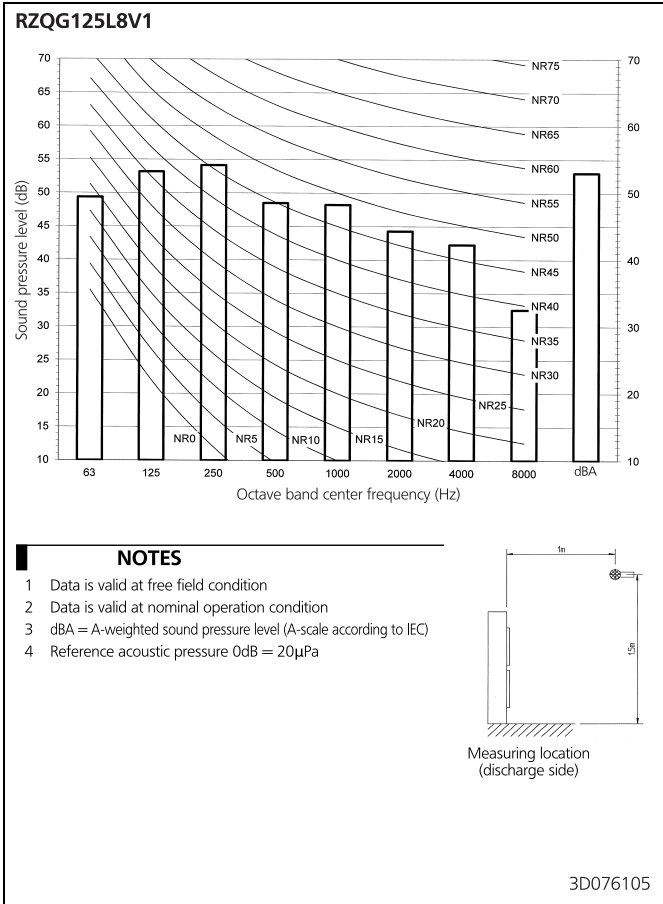
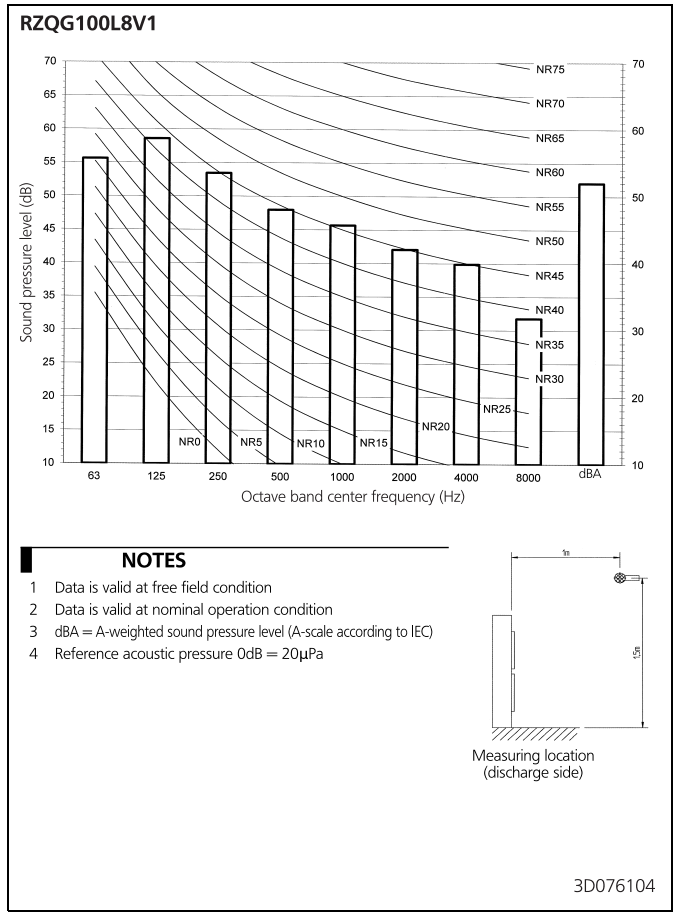
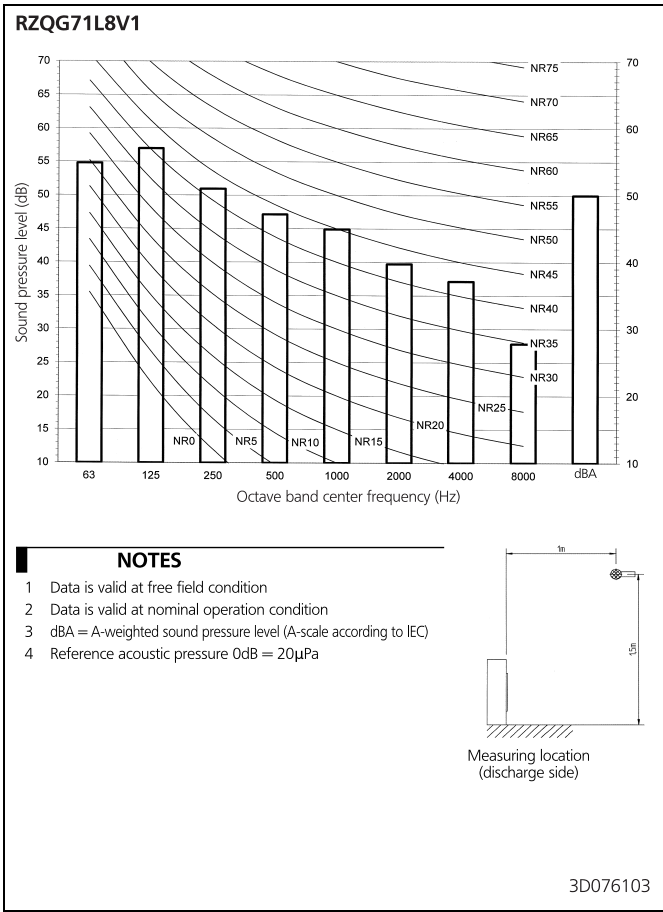

11 Sound data

11 - 4 Sound Pressure Spectrum Quiet Mode

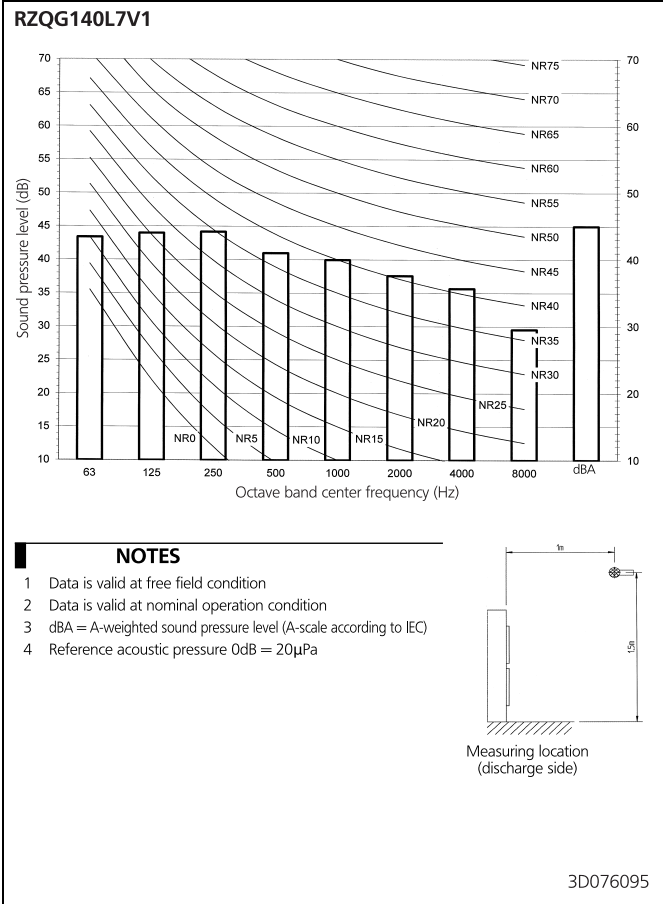
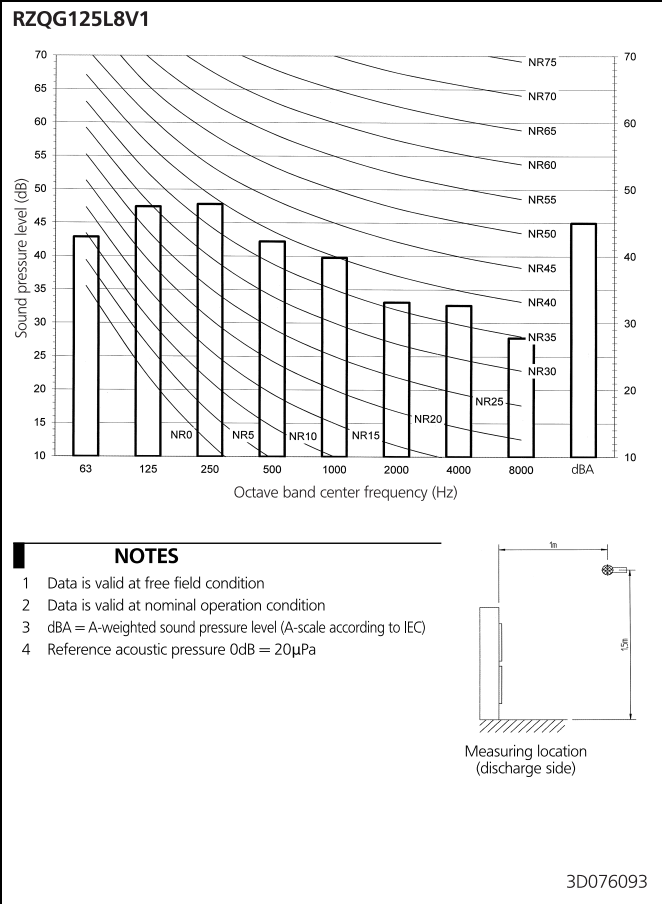
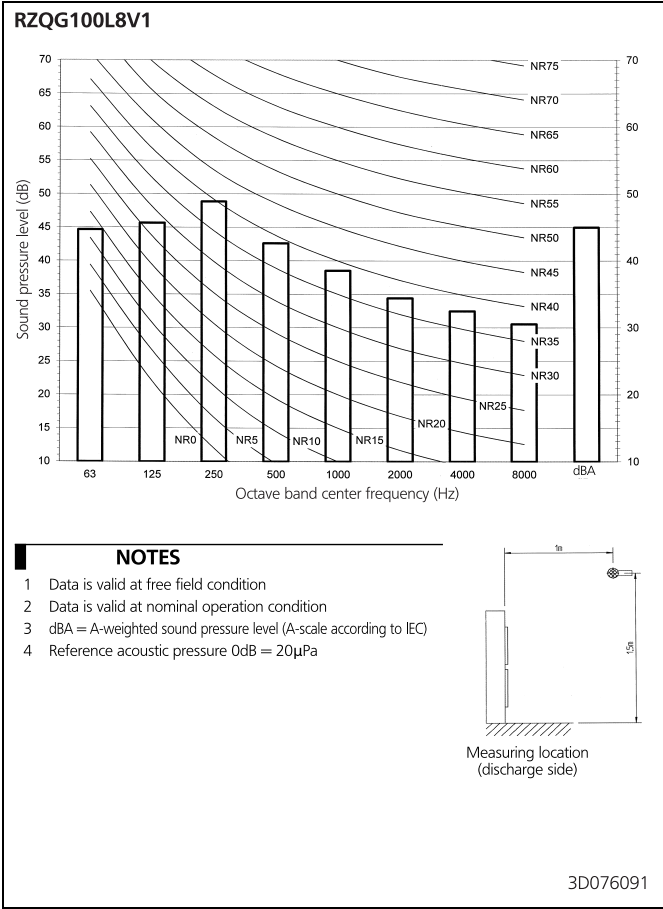
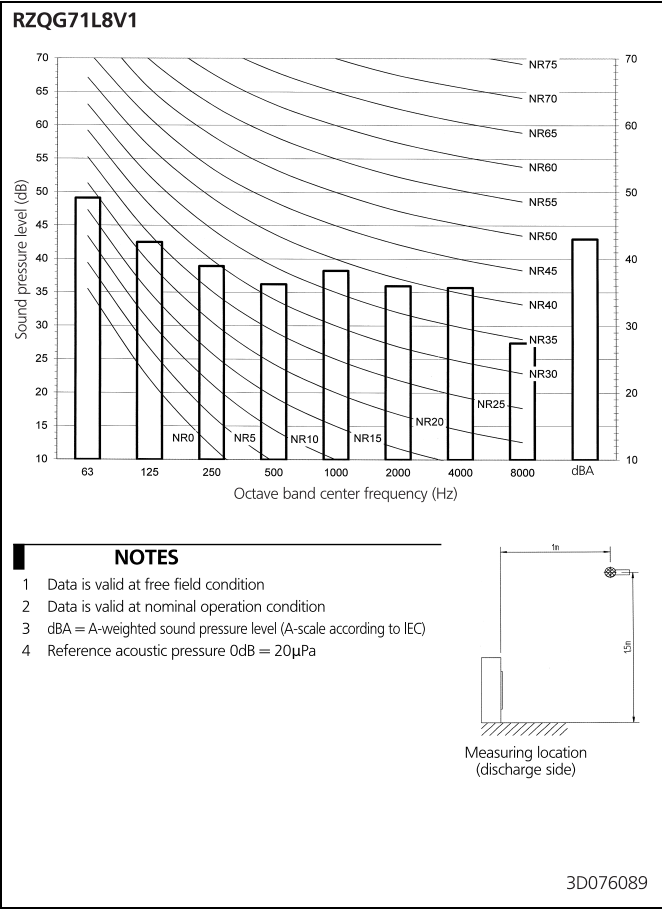

12 Installation

12 - 1 Installation Method

12

RZQG-L8/7V1

Installation service space

The measure of these values is "mm".

(A) When there are obstacles on suction sides.

• No obstacle above

- ① Stand-alone installation
 - Obstacle on the suction side only

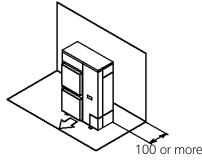

- Obstacle on both sides and suction side, too

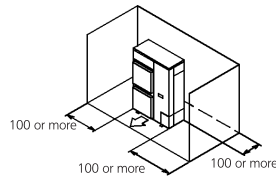

- ② Series installation (2 or more) (Note 1)
 - Obstacle on the suction side and both sides

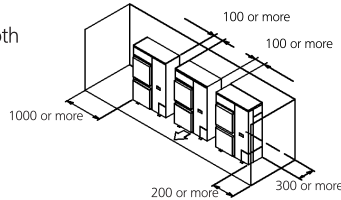

• Obstacle above, too.

- ① Stand-alone installation
 - Obstacle on the suction side, too

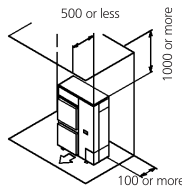

- Obstacle on both sides and suction side, too

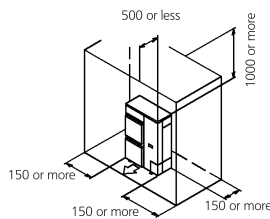

- ② Series installation (2 or more) (Note 1)
 - Obstacle on the suction side and both sides

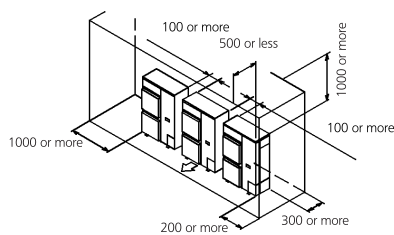

(B) When there are obstacles on discharge sides.

• No obstacle above

- ① Stand-alone installation
 - Obstacle on the discharge side only

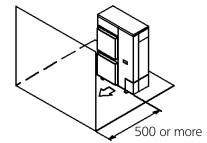

- ② Series installation (2 or more) (Note 1)
 - Obstacle on the discharge side only

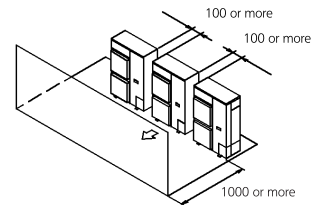

• Obstacle above, too

- ① Stand-alone installation
 - Obstacle on the discharge side only, too

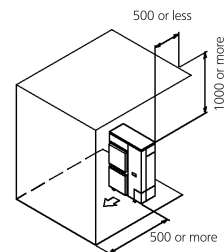

- ② Series installation (2 or more) (Note 1)
 - Obstacle on the discharge side

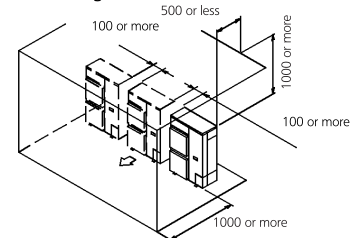

(C) When there are obstacles on both suction and discharge sides.:

Pattern 1

When the obstacles on the discharge side is higher than the unit. (L>H)
(There is no limit for the height of obstructions on the suction side.)

• No obstacle above

- ① Stand-alone installation
 - No obstacle above

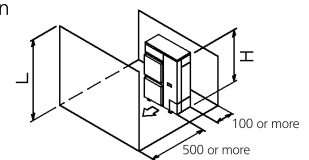

- ② Series installation (2 or more) (Note 1)
 - No obstacle above

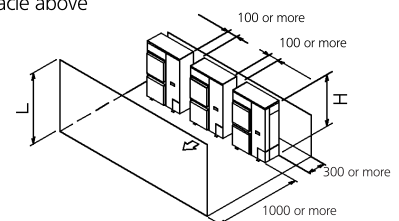

3D069554

12 Installation

12 - 1 Installation Method

RZQG-L8/7V1

● Obstacle above, too

- ① Stand-alone installation (Note 2)
 - When there are obstacles on suction, discharge and top sides.

The relations between H, A and L are as follows.

	L	A
$L \leq H$	$L \leq 1/2 H$ $1/2 H < L \leq H$	750 or more 1000 or more
$L > H$	Set the stand as : $L \leq H$ Refer to the column of $L \leq H$ for A	

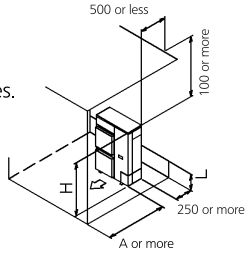

- ② Series installation (2 or more) (Note 1, 2)
 - When there are obstacles on suction, discharge and top sides.

The relations between H, A and L are as follows.

	L	A
$L \leq H$	$L \leq 1/2 H$ $1/2 H < L \leq H$	1000 or more 1250 or more
$L > H$	Set the stand as : $L \leq H$ Refer to the column of $L \leq H$ for A	

Limit of series installation is 2 units.

Pattern 2

When the obstacle on the discharge side is lower than the unit ($L \leq H$) (There is no limit for the height of obstructions on the suction side.)

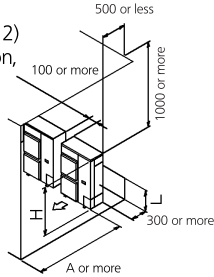

● No obstacle above

- ① Stand-alone installation
 - No obstacle above

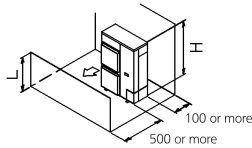

- ② Series installation (2 or more) (Note 1, 2)
 - When there are obstacles on both suction and discharge sides.

The relations between H, A and L are as follows.

	L	A
$L \leq H$	$L \leq 1/2 H$ $1/2 H < L \leq H$	250 or more 300 or more

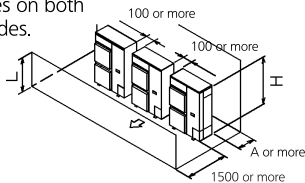

● obstacle above

- ① Stand-alone installation (Note 2)
 - When there are obstacles on suction, discharge and top sides.

The relations between H, A and L are as follows.

	L	A
$L \leq H$	$L \leq 1/2 H$ $1/2 H < L \leq H$	100 or more 200 or more
$L > H$	Set the stand as : $L \leq H$ Refer to the column of $L \leq H$ for A	

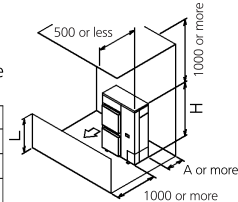

- ② Series installation (2 or more) (Note 1, 2)

- When there are obstacles on suction, discharge and top sides.
- The relations between H, A and L are as follows.

	L	A
$L \leq H$	$L \leq 1/2 H$ $1/2 H < L \leq H$	250 or more 300 or more
$L > H$	Set the stand as : $L \leq H$ Refer to the column of $L \leq H$ for A	

Limit of series installation is 2 units.

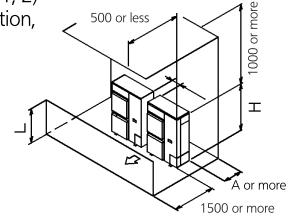

(D) Double-decker installation

- ① Obstacle on the discharge side. (1)
 - Do not exceed two levels for stacked installation.
 - Install a roof cover similar to A (field supply), as outdoor units with downward drainage are prone to dripping and freezing.
 - Install the upper-level outdoor unit so that its bottom plate is a sufficient height above the roof cover. This is to prevent the buildup of ice on the underside of the bottom plate.

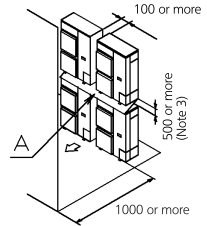

- ② Obstacle on the suction side. (1)
 - Do not exceed two levels for stacked installation.
 - Install a roof cover similar to A (field supply), as outdoor units with downward drainage are prone to dripping and freezing.
 - Install the upper-level outdoor unit so that its bottom plate is a sufficient height above the roof cover. This is to prevent the buildup of ice on the underside of the bottom plate.

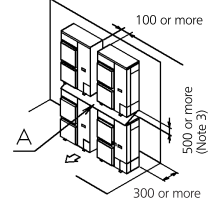

(E) Multiple rows of series installation (on the rooftop, etc.)

- ① One row of stand-alone installation

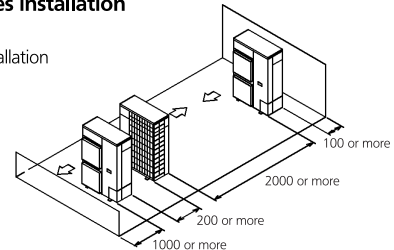

- ② Rows of series installation (2 or more)
- The relations between H, A and L are as follows.

	L	A
$L \leq H$	$L \leq 1/2 H$ $1/2 H < L \leq H$	250 or more 300 or more
$L > H$	Can not be installed	

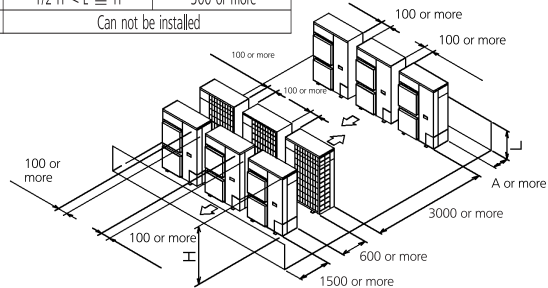

NOTES

- In case of the sideways's piping, make a 100mm gap between the unit above.
- Close the bottom of the installation frame to prevent the discharged air from being bypassed.
- It is not necessary to install a roof cover if there is no danger of drainage dripping and freezing. In this case, the space between the upper and lower outdoor units should be at least 100mm. Close off the gap between the upper and lower units so there is no re-intake of discharged air.

3D069554

13 Operation range

13 - 1 Operation Range

13

RZQG-L8/7V1

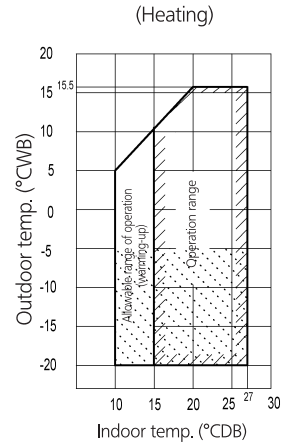
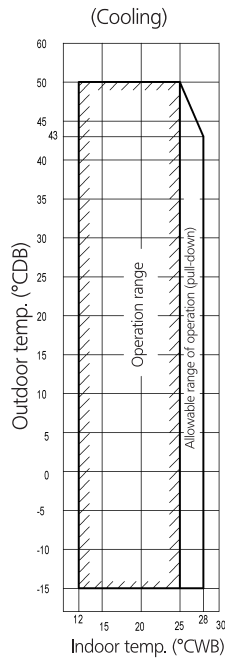

Notes:

- 1 Depending on operation and installation conditions, the indoor unit can change over to freeze-up operation (indoor de-icing).
- 2 To reduce the freeze-up operation (indoor de-icing) frequency, it is recommended to install the outdoor unit in a location not exposed to wind.
- 3 If the unit has to operate for 5 days in this [hatched] operation range with 100% humidity, it is advisable to install the optional bottom plate heater.

3D076502

RZQG-L8/7V1 - EDP Room

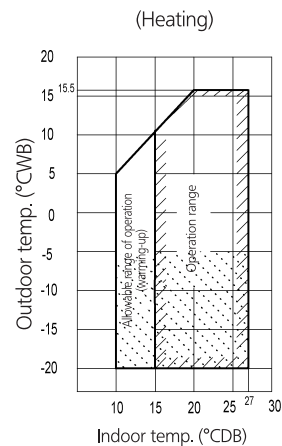
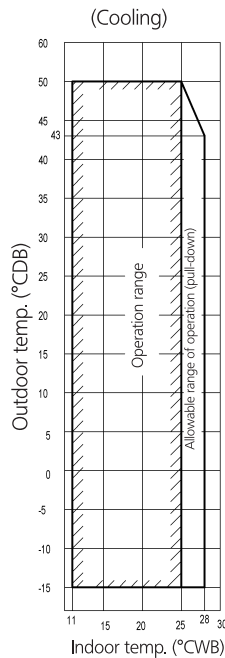

Notes:

- 1 Depending on operation and installation conditions, the indoor unit can change over to freeze-up operation (indoor de-icing).
- 2 To reduce the freeze-up operation (indoor de-icing) frequency, it is recommended to install the outdoor unit in a location not exposed to wind.
- 3 If the unit has to operate for 5 days in this [hatched] operation range with 100% humidity, it is advisable to install the optional bottom plate heater.

3D076503



Daikin Europe N.V. participates in the Eurovent Certification programme for Liquid Chilling Packages (LCP), Air handling units (AHU) and Fan coil units (FCU). Check on-going validity of certificate online: www.eurovent-certification.com or using: www.certiflash.com

The present leaflet is drawn up by way of information only and does not constitute an offer binding upon Daikin Europe N.V.. Daikin Europe N.V. has compiled the content of this leaflet to the best of its knowledge. No express or implied warranty is given for the completeness, accuracy, reliability or fitness for particular purpose of its content and the products and services presented therein. Specifications are subject to change without prior notice. Daikin Europe N.V. explicitly rejects any liability for any direct or indirect damage, in the broadest sense, arising from or related to the use and/or interpretation of this leaflet. All content is copyrighted by Daikin Europe N.V.

BARCODE

Daikin products are distributed by: