

technical data

Wall Mounted Unit
FXAQ-MAVE

air conditioning systems

VRV[®] III-S
VRV[®] III
VRV[®] -WII

R-410A

2e

TABLE OF CONTENTS

FXAQ-MAVE

1	Specifications	2
	Technical Specifications	2
	Electrical Specifications	3
2	Safety device settings	4
3	Options	4
4	Control systems	5
5	Capacity tables	6
	Cooling capacity tables	6
	Heating capacity tables	8
6	Dimensional drawing & centre of gravity	10
	Dimensional drawing	10
7	Piping diagram	12
8	Wiring diagram	13
	Wiring diagram	13
9	Sound data	14
	Sound pressure spectrum	14
10	Installation	16
	Service space	16

1 Specifications

1-1 TECHNICAL SPECIFICATIONS				FXAQ20MAVE	FXAQ25MAVE	FXAQ32MAVE	FXAQ40MAVE	FXAQ50MAVE	FXAQ63MAVE	
Nominal Capacity	Cooling	kW		2.20	2.80	3.60	4.50	5.60	7.10	
	Heating	kW		2.50	3.20	4.00	5.00	6.30	8.00	
Power input (Nominal)	Cooling	kW		0.016	0.022	0.027	0.020	0.027	0.050	
	Heating	kW		0.024	0.027	0.032	0.020	0.032	0.060	
Casing	Colour	white (3.0Y8.5/0.5)								
Dimensions	Unit	Height	mm	290	290	290	290	290	290	
		Width	mm	795	795	795	1050	1050	1050	
		Depth	mm	230	230	230	230	230	230	
Weight	Unit	kg		11	11	11	14	14	14	
Heat Exchanger	Dimensions	Nr of Rows		2	2	2	2	2	2	
		Fin Pitch	mm	1.40	1.40	1.40	1.40	1.40	1.40	
		Face Area	m ²	0.161	0.161	0.161	0.213	0.213	0.213	
		Nr of Stages		14	14	14	14	14	14	
Fan	Type			Cross flow fan						
	Quantity			1	1	1	1			
Air Flow Rate	Cooling	High	m ³ /min	7.50	8.00	9.00	12.00	15.00	19.00	
		Low	m ³ /min	4.50	5.00	5.50	9.00	12.00	14.00	
Fan	Motor	Quantity		1	1	1	1	1	1	
		Model		QCL9661M	QCL9661M	QCL9661M	QCL9686M	QCL9686M	QCL9686M	
		Output (high)	W	40	40	40	43	43	43	
		Drive		Direct drive						
Refrigerant	Name			R-410A						
Cooling	Sound Pressure	High	dBA	35.0	36.0	37.0	39.0	42.0	46.0	
		Low	dBA	29.0	29.0	29.0	34.0	36.0	39.0	
Piping connections	Liquid (OD)	Type			Flare connection					
		Diameter	mm	6.4	6.4	6.4	6.4	6.35	9.5	
	Gas	Type			Flare connection					
		Diameter	mm	12.7	12.7	12.7	12.7	12.7	15.9	
	Drain	Diameter	mm	18	18	18	18	18	18	
Heat Insulation		Foamed polystyrene/polyethylene								
Air Filter	Washable resin net									
Refrigerant control	Electronic expansion valve									
Temperature control	Microprocessor thermostat for cooling and heating									
Safety devices	PC board fuse									
Standard Accessories	Standard Accessories			Installation and operation manual						
				Installation panel						
				Paper pattern for installation						
				Insulation tape						
				Clamps						
				Screws						
Notes				Nominal cooling capacities are based on : indoor temperature : 27° CDB, 19° CWB, outdoor temperature : 35° CDB, equivalent refrigerant piping : 5m (horizontal)						
				Nominal heating capacities are based on : indoor temperature : 20° CDB, outdoor temperature : 7° CDB, 6° CWB, equivalent refrigerant piping : 5m (horizontal)						
				Capacities are net, including a deduction for cooling (an addition for heating) for indoor fan motor heat.						

1 Specifications

1-2 ELECTRICAL SPECIFICATIONS			FXAQ20MAVE	FXAQ25MAVE	FXAQ32MAVE	FXAQ40MAVE	FXAQ50MAVE	FXAQ63MAVE	
Power Supply	Name	VE							
	Phase	1	1	1	1	1	1	1	
	Frequency	Hz	50	50	50	50	50	50	
	Voltage	V	220-240						
Current	Minimum circuit amps (MCA)	A	0.30	0.40	0.40	0.40	0.40	0.60	
	Maximum fuse amps (MFA)	A	15.00	15.00	15.00	15.00	15.00	15.00	
	Full load amps (FLA)	A	0.20	0.30	0.30	0.30	0.30	0.50	
Voltage range	Minimum	V	-10%						
	Maximum	V	+10%						
Notes	Voltage range : units are suitable for use on electrical systems where voltage supplied to unit terminals is not below or above listed range limits.								
	Maximum allowable voltage range variation between phases is 2%.								
	MCA/MFA : MCA = 1.25 x FLA								
	MFA <= 4 x FLA								
	next lower standard fuse rating minimum 15A								
	select wire size based on the MCA								
	instead of a fuse, use a circuit breaker								
	For more details concerning conditional connections, see http://extranet.daikineurope.com , select "E-Data Books". Finally, click on the document title of your choice.								

2 Safety device settings

	FXAQ20MA	FXAQ25MA	FXAQ32MA	FXAQ40MA	FXAQ50MA	FXAQ63MA
PC BOARD FUSE	250V 3A					
4D034906F						

3 Options

	FXAQ20MA	FXAQ25MA	FXAQ32MA	FXAQ40MA	FXAQ50MA	FXAQ63MA
DRAIN PUMP KIT	K-KDU572CVE					
ED39-226B						

4 Control systems

Individual control systems

		FXAQ20MA	FXAQ25MA	FXAQ32MA	FXAQ40MA	FXAQ50MA	FXAQ63MA
WIRED REMOTE CONTROL		BRC1D52					
INFRARED REMOTE CONTROL	Heat pump	BRC7E618					
	Cooling only	BRC7E619					

Centralised control systems

		FXAQ20MA	FXAQ25MA	FXAQ32MA	FXAQ40MA	FXAQ50MA	FXAQ63MA
CENTRALISED REMOTE CONTROL		DCS302C51					
UNIFIED ON/OFF CONTROL		DCS301B51					
SCHEDULE TIMER		DST301B51					

Others

		FXAQ20MA	FXAQ25MA	FXAQ32MA	FXAQ40MA	FXAQ50MA	FXAQ63MA
WIRING ADAPTER FOR ELECTRICAL APPENDICES (1)		KRP2A51#					
WIRING ADAPTER FOR ELECTRICAL APPENDICES (2)		KRP4A51#					
INSTALLATION BOX FOR ADAPTER PCB (2) (3)		KRP4A93					
REMOTE SENSOR		KRCS01-1					
ELECTRICAL BOX WITH EARTH TERMINAL (3 BLOCKS)		KJB311A					
ELECTRICAL BOX WITH EARTH TERMINAL (2 BLOCKS)		KJB212A					
NOISE FILTER (FOR ELECTROMAGNETIC INTERFACE USE ONLY)		KEK26-1A					
EXTERNAL CONTROL ADAPTER FOR OUTDOOR UNITS (INSTALLATION ON INDOOR UNIT)		DTA104A61#					

PCV0320

NOTES

- 1 Installation box is necessary for each adapter marked with #.
- 2 Up to 2 adapters can be fixed per installation box.
- 3 Only 1 installation box can be installed per indoor unit.

5 Capacity tables

5 - 1 Cooling capacity tables

FXAQ-MA		TC: Total capacity,kW – SHC: Sensible capacity,kW															
Unit size	Nominal capacity	Outdoor air temp. °CDB	Indoor air temperature														
			14.OWB		16.OWB		18.OWB		19.OWB		20.OWB		22.OWB		24.OWB		
			TC	SHC	TC	SHC	TC	SHC	TC	SHC	TC	SHC	TC	SHC	TC	SHC	
20	2.2	10.0	1.5	1.5	1.8	1.8	2.1	1.9	2.2	1.9	2.3	1.9	2.6	2.0	2.9	1.9	
		12.0	1.5	1.5	1.8	1.8	2.1	1.9	2.2	1.9	2.3	1.9	2.6	2.0	2.9	1.9	
		14.0	1.5	1.5	1.8	1.8	2.1	1.9	2.2	1.9	2.3	1.9	2.6	2.0	2.8	1.9	
		16.0	1.5	1.5	1.8	1.8	2.1	1.9	2.2	1.9	2.3	1.9	2.6	2.0	2.8	1.9	
		18.0	1.5	1.5	1.8	1.8	2.1	1.9	2.2	1.9	2.3	1.9	2.6	2.0	2.7	1.9	
		20.0	1.5	1.5	1.8	1.8	2.1	1.9	2.2	1.9	2.3	1.9	2.6	2.0	2.7	1.9	
		21.0	1.5	1.5	1.8	1.8	2.1	1.9	2.2	1.9	2.3	1.9	2.6	2.0	2.7	1.9	
		23.0	1.5	1.5	1.8	1.8	2.1	1.9	2.2	1.9	2.3	1.9	2.6	1.9	2.6	1.9	
		25.0	1.5	1.5	1.8	1.8	2.1	1.9	2.2	1.9	2.3	1.9	2.6	1.9	2.6	1.9	
		27.0	1.5	1.5	1.8	1.8	2.1	1.9	2.2	1.9	2.3	1.9	2.5	1.9	2.6	1.8	
		29.0	1.5	1.5	1.8	1.8	2.1	1.9	2.2	1.9	2.3	1.9	2.5	1.9	2.5	1.8	
		31.0	1.5	1.5	1.8	1.8	2.1	1.9	2.2	1.9	2.3	1.9	2.4	1.9	2.5	1.8	
		33.0	1.5	1.5	1.8	1.8	2.1	1.9	2.2	1.9	2.3	1.9	2.4	1.9	2.5	1.8	
		35.0	1.5	1.5	1.8	1.8	2.1	1.9	2.2	1.9	2.3	1.9	2.4	1.9	2.4	1.8	
		37.0	1.5	1.5	1.8	1.8	2.1	1.9	2.2	1.9	2.3	1.9	2.3	1.8	2.4	1.7	
		39.0	1.5	1.5	1.8	1.8	2.1	1.9	2.2	1.9	2.2	1.9	2.3	1.8	2.3	1.7	
25	2.8	10.0	1.9	1.8	2.3	2.0	2.6	2.2	2.8	2.2	3.0	2.2	3.4	2.3	3.7	2.3	
		12.0	1.9	1.8	2.3	2.0	2.6	2.2	2.8	2.2	3.0	2.2	3.4	2.3	3.6	2.2	
		14.0	1.9	1.8	2.3	2.0	2.6	2.2	2.8	2.2	3.0	2.2	3.4	2.3	3.6	2.3	
		16.0	1.9	1.8	2.3	2.0	2.6	2.2	2.8	2.2	3.0	2.2	3.4	2.3	3.5	2.2	
		18.0	1.9	1.8	2.3	2.0	2.6	2.2	2.8	2.2	3.0	2.2	3.4	2.3	3.5	2.2	
		20.0	1.9	1.8	2.3	2.0	2.6	2.2	2.8	2.2	3.0	2.2	3.4	2.3	3.4	2.2	
		21.0	1.9	1.8	2.3	2.0	2.6	2.2	2.8	2.2	3.0	2.2	3.4	2.3	3.4	2.2	
		23.0	1.9	1.8	2.3	2.0	2.6	2.2	2.8	2.2	3.0	2.2	3.3	2.3	3.4	2.2	
		25.0	1.9	1.8	2.3	2.0	2.6	2.2	2.8	2.2	3.0	2.2	3.3	2.2	3.3	2.2	
		27.0	1.9	1.8	2.3	2.0	2.6	2.2	2.8	2.2	3.0	2.2	3.2	2.2	3.3	2.1	
		29.0	1.9	1.8	2.3	2.0	2.6	2.2	2.8	2.2	3.0	2.2	3.2	2.2	3.2	2.1	
		31.0	1.9	1.8	2.3	2.0	2.6	2.2	2.8	2.2	3.0	2.2	3.1	2.2	3.2	2.1	
		33.0	1.9	1.8	2.3	2.0	2.6	2.2	2.8	2.2	3.0	2.2	3.1	2.2	3.1	2.1	
		35.0	1.9	1.8	2.3	2.0	2.6	2.2	2.8	2.2	3.0	2.2	3.0	2.2	3.1	2.1	
		37.0	1.9	1.8	2.3	2.0	2.6	2.2	2.8	2.2	2.9	2.2	3.0	2.1	3.0	2.0	
		39.0	1.9	1.8	2.3	2.0	2.6	2.2	2.8	2.2	2.9	2.2	2.9	2.1	3.0	2.0	
32	3.6	10.0	2.4	2.2	2.9	2.4	3.4	2.6	3.6	2.7	3.8	2.7	4.3	2.8	4.7	2.8	
		12.0	2.4	2.2	2.9	2.4	3.4	2.6	3.6	2.7	3.8	2.7	4.3	2.8	4.7	2.8	
		14.0	2.4	2.2	2.9	2.4	3.4	2.6	3.6	2.7	3.8	2.7	4.3	2.8	4.6	2.8	
		16.0	2.4	2.2	2.9	2.4	3.4	2.6	3.6	2.7	3.8	2.7	4.3	2.8	4.6	2.8	
		18.0	2.4	2.2	2.9	2.4	3.4	2.6	3.6	2.7	3.8	2.7	4.3	2.8	4.5	2.7	
		20.0	2.4	2.2	2.9	2.4	3.4	2.6	3.6	2.7	3.8	2.7	4.3	2.8	4.4	2.7	
		21.0	2.4	2.2	2.9	2.4	3.4	2.6	3.6	2.7	3.8	2.7	4.3	2.8	4.4	2.7	
		23.0	2.4	2.2	2.9	2.4	3.4	2.6	3.6	2.7	3.8	2.7	4.2	2.8	4.3	2.7	
		25.0	2.4	2.2	2.9	2.4	3.4	2.6	3.6	2.7	3.8	2.7	4.2	2.8	4.3	2.6	
		27.0	2.4	2.2	2.9	2.4	3.4	2.6	3.6	2.7	3.8	2.7	4.1	2.7	4.2	2.6	
		29.0	2.4	2.2	2.9	2.4	3.4	2.6	3.6	2.7	3.8	2.7	4.1	2.7	4.2	2.6	
		31.0	2.4	2.2	2.9	2.4	3.4	2.6	3.6	2.7	3.8	2.7	4.0	2.7	4.1	2.6	
		33.0	2.4	2.2	2.9	2.4	3.4	2.6	3.6	2.7	3.8	2.7	3.9	2.6	4.0	2.5	
		35.0	2.4	2.2	2.9	2.4	3.4	2.6	3.6	2.7	3.8	2.7	3.9	2.6	4.0	2.5	
		37.0	2.4	2.2	2.9	2.4	3.4	2.6	3.6	2.7	3.7	2.6	3.8	2.6	3.9	2.5	
		39.0	2.4	2.2	2.9	2.4	3.4	2.6	3.6	2.7	3.7	2.6	3.8	2.6	3.8	2.5	
40	4.5	10.0	3.0	2.9	3.6	3.3	4.2	3.7	4.5	3.5	4.8	3.6	5.4	3.6	5.9	3.6	
		12.0	3.0	2.9	3.6	3.3	4.2	3.7	4.5	3.5	4.8	3.6	5.4	3.6	5.8	3.5	
		14.0	3.0	2.9	3.6	3.3	4.2	3.7	4.5	3.5	4.8	3.6	5.4	3.6	5.8	3.5	
		16.0	3.0	2.9	3.6	3.3	4.2	3.7	4.5	3.5	4.8	3.6	5.4	3.6	5.7	3.5	
		18.0	3.0	2.9	3.6	3.3	4.2	3.7	4.5	3.5	4.8	3.6	5.4	3.6	5.6	3.4	
		20.0	3.0	2.9	3.6	3.3	4.2	3.7	4.5	3.5	4.8	3.6	5.4	3.6	5.5	3.4	
		21.0	3.0	2.9	3.6	3.3	4.2	3.7	4.5	3.5	4.8	3.6	5.4	3.6	5.5	3.4	
		23.0	3.0	2.9	3.6	3.3	4.2	3.7	4.5	3.5	4.8	3.6	5.3	3.6	5.4	3.3	
		25.0	3.0	2.9	3.6	3.3	4.2	3.7	4.5	3.5	4.8	3.6	5.2	3.6	5.3	3.3	
		27.0	3.0	2.9	3.6	3.3	4.2	3.7	4.5	3.5	4.8	3.6	5.2	3.5	5.3	3.3	
		29.0	3.0	2.9	3.6	3.3	4.2	3.7	4.5	3.5	4.8	3.6	5.1	3.5	5.2	3.2	
		31.0	3.0	2.9	3.6	3.3	4.2	3.7	4.5	3.5	4.8	3.6	5.0	3.4	5.1	3.2	
		33.0	3.0	2.9	3.6	3.3	4.2	3.7	4.5	3.5	4.8	3.6	4.9	3.4	5.0	3.1	
		35.0	3.0	2.9	3.6	3.3	4.2	3.7	4.5	3.5	4.7	3.6	4.9	3.4	5.0	3.1	
		37.0	3.0	2.9	3.6	3.3	4.2	3.7	4.5	3.5	4.7	3.5	4.8	3.3	4.9	3.1	
		39.0	3.0	2.9	3.6	3.3	4.2	3.7	4.5	3.5	4.6	3.5	4.7	3.3	4.8	3.0	

5 Capacity tables

5 - 1 Cooling capacity tables

FXAQ-MA		TC: Total capacity;kW - SHC: Sensible capacity;kW														
Unit size	Nominal capacity	Outdoor air temp.	Indoor air temperature													
			14.OWB		16.OWB		18.OWB		19.OWB		20.OWB		22.OWB		24.OWB	
			20.ODB		23.ODB		26.ODB		27.ODB		28.ODB		30.ODB		32.ODB	
		°CDB	TC	SHC	TC	SHC	TC	SHC	TC	SHC	TC	SHC	TC	SHC	TC	SHC
50	5.6	10.0	3.8	3.2	4.5	3.7	5.2	4.1	5.6	4.2	6.0	4.3	6.7	4.4	7.4	4.4
		12.0	3.8	3.2	4.5	3.7	5.2	4.1	5.6	4.2	6.0	4.3	6.7	4.4	7.3	4.3
		14.0	3.8	3.2	4.5	3.7	5.2	4.1	5.6	4.2	6.0	4.3	6.7	4.4	7.2	4.3
		16.0	3.8	3.2	4.5	3.7	5.2	4.1	5.6	4.2	6.0	4.3	6.7	4.4	7.1	4.3
		18.0	3.8	3.2	4.5	3.7	5.2	4.1	5.6	4.2	6.0	4.3	6.7	4.4	7.0	4.2
		20.0	3.8	3.2	4.5	3.7	5.2	4.1	5.6	4.2	6.0	4.3	6.7	4.4	6.9	4.2
		21.0	3.8	3.2	4.5	3.7	5.2	4.1	5.6	4.2	6.0	4.3	6.7	4.4	6.8	4.2
		23.0	3.8	3.2	4.5	3.7	5.2	4.1	5.6	4.2	6.0	4.3	6.6	4.4	6.7	4.1
		25.0	3.8	3.2	4.5	3.7	5.2	4.1	5.6	4.2	6.0	4.3	6.5	4.3	6.6	4.1
		27.0	3.8	3.2	4.5	3.7	5.2	4.1	5.6	4.2	6.0	4.3	6.4	4.3	6.6	4.0
		29.0	3.8	3.2	4.5	3.7	5.2	4.1	5.6	4.2	6.0	4.3	6.3	4.2	6.5	4.0
		31.0	3.8	3.2	4.5	3.7	5.2	4.1	5.6	4.2	6.0	4.3	6.2	4.2	6.4	3.9
		33.0	3.8	3.2	4.5	3.7	5.2	4.1	5.6	4.2	6.0	4.3	6.1	4.2	6.3	3.9
		35.0	3.8	3.2	4.5	3.7	5.2	4.1	5.6	4.2	5.9	4.3	6.0	4.1	6.2	3.8
		37.0	3.8	3.2	4.5	3.7	5.2	4.1	5.6	4.2	5.8	4.3	5.9	4.1	6.1	3.8
		39.0	3.8	3.2	4.5	3.7	5.2	4.1	5.6	4.2	5.7	4.2	5.8	4.0	6.0	3.8
63	7.1	10.0	4.8	4.1	5.7	4.6	6.6	5.1	7.1	5.3	7.6	5.4	8.5	5.6	9.3	5.3
		12.0	4.8	4.1	5.7	4.6	6.6	5.1	7.1	5.3	7.6	5.4	8.5	5.6	9.2	5.3
		14.0	4.8	4.1	5.7	4.6	6.6	5.1	7.1	5.3	7.6	5.4	8.5	5.6	9.1	5.2
		16.0	4.8	4.1	5.7	4.6	6.6	5.1	7.1	5.3	7.6	5.4	8.5	5.6	9.0	5.2
		18.0	4.8	4.1	5.7	4.6	6.6	5.1	7.1	5.3	7.6	5.4	8.5	5.6	8.8	5.2
		20.0	4.8	4.1	5.7	4.6	6.6	5.1	7.1	5.3	7.6	5.4	8.5	5.6	8.7	5.1
		21.0	4.8	4.1	5.7	4.6	6.6	5.1	7.1	5.3	7.6	5.4	8.5	5.6	8.7	5.1
		23.0	4.8	4.1	5.7	4.6	6.6	5.1	7.1	5.3	7.6	5.4	8.4	5.5	8.5	5.0
		25.0	4.8	4.1	5.7	4.6	6.6	5.1	7.1	5.3	7.6	5.4	8.3	5.5	8.4	5.0
		27.0	4.8	4.1	5.7	4.6	6.6	5.1	7.1	5.3	7.6	5.4	8.1	5.4	8.3	4.9
		29.0	4.8	4.1	5.7	4.6	6.6	5.1	7.1	5.3	7.6	5.4	8.0	5.4	8.2	4.9
		31.0	4.8	4.1	5.7	4.6	6.6	5.1	7.1	5.3	7.6	5.4	7.9	5.3	8.1	4.8
		33.0	4.8	4.1	5.7	4.6	6.6	5.1	7.1	5.3	7.6	5.4	7.8	5.2	7.9	4.8
		35.0	4.8	4.1	5.7	4.6	6.6	5.1	7.1	5.3	7.5	5.4	7.7	5.2	7.8	4.7
		37.0	4.8	4.1	5.7	4.6	6.6	5.1	7.1	5.3	7.4	5.3	7.5	5.1	7.7	4.7
		39.0	4.8	4.1	5.7	4.6	6.6	5.1	7.1	5.3	7.2	5.3	7.4	5.1	7.6	4.6

5 Capacity tables

5 - 2 Heating capacity tables

FXAQ-MA									
Unit Size	Nominal capacity	Outdoor air temperature		Indoor air temperature °CDB					
				16.0	18.0	20.0	21.0	22.0	24.0
		°CDB	°CWB	kW	kW	kW	kW	kW	kW
20	2.5	-19.8	-20.0	1.5	1.5	1.5	1.5	1.5	1.5
		-18.8	-19.0	1.5	1.5	1.5	1.5	1.5	1.5
		-16.7	-17.0	1.6	1.6	1.6	1.6	1.6	1.6
		-14.7	-15.0	1.7	1.7	1.7	1.7	1.7	1.7
		-12.6	-13.0	1.8	1.8	1.8	1.8	1.8	1.8
		-10.5	-11.0	1.9	1.9	1.9	1.9	1.9	1.9
		-9.5	-10.0	1.9	1.9	1.9	1.9	1.9	1.9
		-8.5	-9.1	2.0	2.0	1.9	1.9	1.9	1.9
		-7.0	-7.6	2.0	2.0	2.0	2.0	2.0	2.0
		-5.0	-5.6	2.1	2.1	2.1	2.1	2.1	2.1
		-3.0	-3.7	2.2	2.2	2.2	2.2	2.2	2.2
		0.0	-0.7	2.3	2.3	2.3	2.3	2.3	2.2
		3.0	2.2	2.5	2.5	2.4	2.4	2.3	2.2
		5.0	4.1	2.5	2.5	2.5	2.4	2.3	2.2
		7.0	6.0	2.6	2.6	2.5	2.4	2.3	2.2
		9.0	7.9	2.7	2.7	2.5	2.4	2.3	2.2
		11.0	9.8	2.8	2.7	2.5	2.4	2.3	2.2
13.0	11.8	2.8	2.7	2.5	2.4	2.3	2.2		
15.0	13.7	2.8	2.7	2.5	2.4	2.3	2.2		
25	3.2	-19.8	-20.0	1.9	1.9	1.9	1.9	1.9	1.9
		-18.8	-19.0	1.9	1.9	1.9	1.9	1.9	1.9
		-16.7	-17.0	2.1	2.1	2.0	2.0	2.0	2.0
		-14.7	-15.0	2.2	2.2	2.2	2.2	2.2	2.1
		-12.6	-13.0	2.3	2.3	2.3	2.3	2.3	2.3
		-10.5	-11.0	2.4	2.4	2.4	2.4	2.4	2.4
		-9.5	-10.0	2.5	2.4	2.4	2.4	2.4	2.4
		-8.5	-9.1	2.5	2.5	2.5	2.5	2.5	2.5
		-7.0	-7.6	2.6	2.6	2.6	2.6	2.6	2.6
		-5.0	-5.6	2.7	2.7	2.7	2.7	2.7	2.7
		-3.0	-3.7	2.8	2.8	2.8	2.8	2.8	2.8
		0.0	-0.7	3.0	3.0	3.0	3.0	3.0	2.8
		3.0	2.2	3.1	3.1	3.1	3.1	3.0	2.8
		5.0	4.1	3.3	3.2	3.2	3.1	3.0	2.8
		7.0	6.0	3.4	3.4	3.2	3.1	3.0	2.8
		9.0	7.9	3.5	3.4	3.2	3.1	3.0	2.8
		11.0	9.8	3.6	3.4	3.2	3.1	3.0	2.8
13.0	11.8	3.6	3.4	3.2	3.1	3.0	2.8		
15.0	13.7	3.6	3.4	3.2	3.1	3.0	2.8		
32	4.0	-19.8	-20.0	2.4	2.4	2.3	2.3	2.3	2.3
		-18.8	-19.0	2.4	2.4	2.4	2.4	2.4	2.4
		-16.7	-17.0	2.6	2.6	2.6	2.6	2.6	2.5
		-14.7	-15.0	2.7	2.7	2.7	2.7	2.7	2.7
		-12.6	-13.0	2.9	2.8	2.8	2.8	2.8	2.8
		-10.5	-11.0	3.0	3.0	3.0	3.0	3.0	3.0
		-9.5	-10.0	3.1	3.1	3.1	3.1	3.0	3.0
		-8.5	-9.1	3.1	3.1	3.1	3.1	3.1	3.1
		-7.0	-7.6	3.2	3.2	3.2	3.2	3.2	3.2
		-5.0	-5.6	3.4	3.4	3.4	3.4	3.4	3.4
		-3.0	-3.7	3.5	3.5	3.5	3.5	3.5	3.5
		0.0	-0.7	3.7	3.7	3.7	3.7	3.7	3.5
		3.0	2.2	3.9	3.9	3.9	3.9	3.7	3.5
		5.0	4.1	4.1	4.1	4.0	3.9	3.7	3.5
		7.0	6.0	4.2	4.2	4.0	3.9	3.7	3.5
		9.0	7.9	4.3	4.3	4.0	3.9	3.7	3.5
		11.0	9.8	4.5	4.3	4.0	3.9	3.7	3.5
13.0	11.8	4.5	4.3	4.0	3.9	3.7	3.5		
15.0	13.7	4.5	4.3	4.0	3.9	3.7	3.5		
40	5.0	-19.8	-20.0	3.0	2.9	2.9	2.9	2.9	2.9
		-18.8	-19.0	3.0	3.0	3.0	3.0	3.0	3.0
		-16.7	-17.0	3.2	3.2	3.2	3.2	3.2	3.2
		-14.7	-15.0	3.4	3.4	3.4	3.4	3.4	3.4
		-12.6	-13.0	3.6	3.6	3.6	3.5	3.5	3.5
		-10.5	-11.0	3.7	3.7	3.7	3.7	3.7	3.7
		-9.5	-10.0	3.8	3.8	3.8	3.8	3.8	3.8
		-8.5	-9.1	3.9	3.9	3.9	3.9	3.9	3.9
		-7.0	-7.6	4.0	4.0	4.0	4.0	4.0	4.0
		-5.0	-5.6	4.2	4.2	4.2	4.2	4.2	4.2
		-3.0	-3.7	4.4	4.4	4.4	4.4	4.4	4.4
		0.0	-0.7	4.7	4.6	4.6	4.6	4.6	4.4
		3.0	2.2	4.9	4.9	4.9	4.8	4.7	4.4
		5.0	4.1	5.1	5.1	5.0	4.8	4.7	4.4
		7.0	6.0	5.2	5.2	5.0	4.8	4.7	4.4
		9.0	7.9	5.4	5.3	5.0	4.8	4.7	4.4
		11.0	9.8	5.6	5.3	5.0	4.8	4.7	4.4
13.0	11.8	5.6	5.3	5.0	4.8	4.7	4.4		
15.0	13.7	5.6	5.3	5.0	4.8	4.7	4.4		

5 Capacity tables

5 - 2 Heating capacity tables

FXAQ-MA									
Unit Size	Nominal capacity	Outdoor air temperature		Indoor air temperature °CDB					
				16.0	18.0	20.0	21.0	22.0	24.0
		°CDB	°CWB	kW	kW	kW	kW	kW	kW
50	63	-19.8	-20.0	3.7	3.7	3.7	3.7	3.7	3.7
		-18.8	-19.0	3.8	3.8	3.8	3.8	3.8	3.8
		-16.7	-17.0	4.1	4.0	4.0	4.0	4.0	4.0
		-14.7	-15.0	4.3	4.3	4.3	4.2	4.2	4.2
		-12.6	-13.0	4.5	4.5	4.5	4.5	4.5	4.5
		-10.5	-11.0	4.7	4.7	4.7	4.7	4.7	4.7
		-9.5	-10.0	4.8	4.8	4.8	4.8	4.8	4.8
		-8.5	-9.1	4.9	4.9	4.9	4.9	4.9	4.9
		-7.0	-7.6	5.1	5.1	5.1	5.1	5.1	5.1
		-5.0	-5.6	5.3	5.3	5.3	5.3	5.3	5.3
		-3.0	-3.7	5.5	5.5	5.5	5.5	5.5	5.5
		0.0	-0.7	5.9	5.9	5.8	5.8	5.8	5.5
		3.0	2.2	6.2	6.2	6.2	6.1	5.9	5.5
		5.0	4.1	6.4	6.4	6.3	6.1	5.9	5.5
		7.0	6.0	6.6	6.6	6.3	6.1	5.9	5.5
		9.0	7.9	6.8	6.7	6.3	6.1	5.9	5.5
		11.0	9.8	7.0	6.7	6.3	6.1	5.9	5.5
13.0	11.8	7.1	6.7	6.3	6.1	5.9	5.5		
15.0	13.7	7.1	6.7	6.3	6.1	5.9	5.5		
63	8.0	-19.8	-20.0	4.7	4.7	4.7	4.7	4.7	4.7
		-18.8	-19.0	4.9	4.9	4.8	4.8	4.8	4.8
		-16.7	-17.0	5.1	5.1	5.1	5.1	5.1	5.1
		-14.7	-15.0	5.4	5.4	5.4	5.4	5.4	5.4
		-12.6	-13.0	5.7	5.7	5.7	5.7	5.7	5.7
		-10.5	-11.0	6.0	6.0	6.0	6.0	6.0	5.9
		-9.5	-10.0	6.1	6.1	6.1	6.1	6.1	6.1
		-8.5	-9.1	6.3	6.3	6.2	6.2	6.2	6.2
		-7.0	-7.6	6.5	6.5	6.4	6.4	6.4	6.4
		-5.0	-5.6	6.8	6.7	6.7	6.7	6.7	6.7
		-3.0	-3.7	7.0	7.0	7.0	7.0	7.0	7.0
		0.0	-0.7	7.5	7.4	7.4	7.4	7.4	7.0
		3.0	2.2	7.9	7.8	7.8	7.7	7.5	7.0
		5.0	4.1	8.1	8.1	8.0	7.7	7.5	7.0
		7.0	6.0	8.4	8.4	8.0	7.7	7.5	7.0
		9.0	7.9	8.7	8.5	8.0	7.7	7.5	7.0
		11.0	9.8	8.9	8.5	8.0	7.7	7.5	7.0
13.0	11.8	9.0	8.5	8.0	7.7	7.5	7.0		
15.0	13.7	9.0	8.5	8.0	7.7	7.5	7.0		

6 Dimensional drawing & centre of gravity

6 - 1 Dimensional drawing

FXAQ20,25,32MA

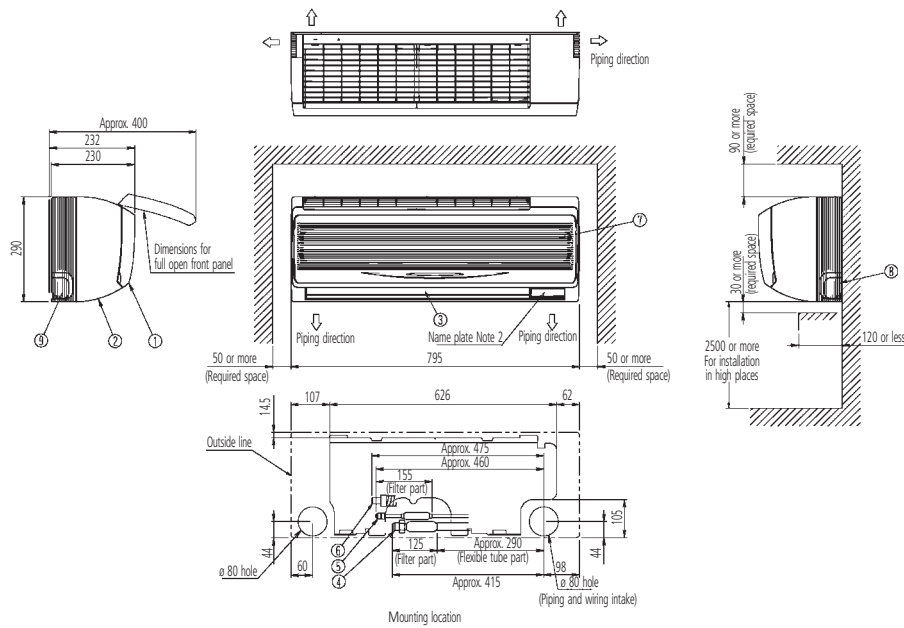

Nr	Part name	Description
1	Front panel	
2	Front grill	
3	Air outlet	
4	Gas pipe	ø 12.7 Flare connection
5	Liquid pipe	ø 6.4 Flare connection
6	Drain hose	VP13 (External dia. ø18)
7	Grounding terminal	M4
8	Right side pipe connection hole	
9	Left side pipe connection hole	

NOTES

- 1 Name plate location: right side surface of casing
- 2 In case of using an infrared remote control, this position will be a signal receiver. Refer to the drawing of an infrared remote control in detail.

3D034903C

FXAQ40,50MA

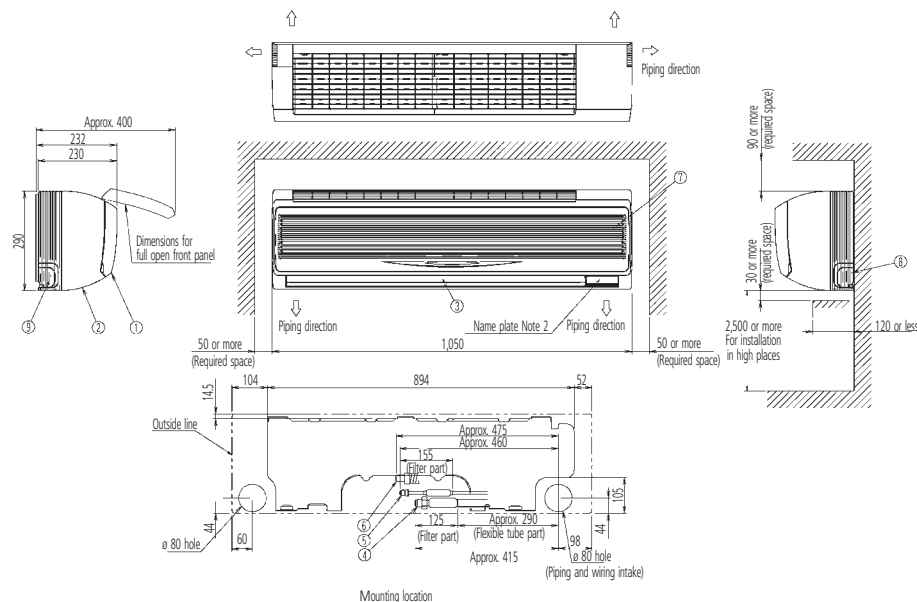

Nr	Part name	Description
1	Front panel	
2	Front grill	
3	Air outlet	
4	Gas pipe	ø 12.7 Flare connection
5	Liquid pipe	ø 6.4 Flare connection
6	Drain hose	VP13 (External dia. ø 18)
7	Grounding terminal	M4
8	Right side pipe connection hole	
9	Left side pipe connection hole	

NOTES

- 1 Name plate location: right side surface of casing.
- 2 In case of using an infrared remote control, this position will be a signal receiver. Refer to the drawing of the infrared remote control in detail.

3D038539B

7 Piping diagram

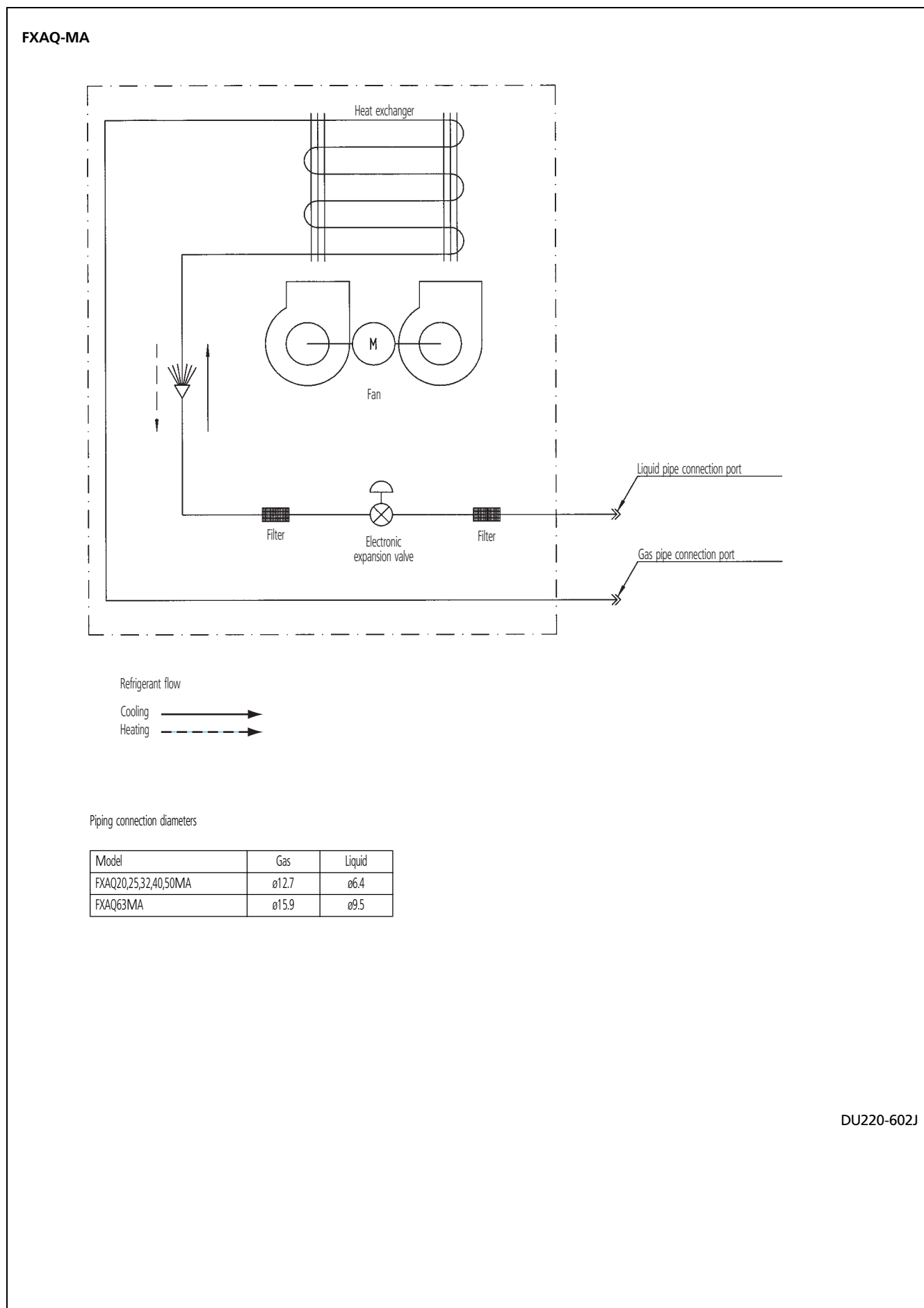

DU220-602J

8 Wiring diagram

8 - 1 Wiring diagram

FXAQ-MA

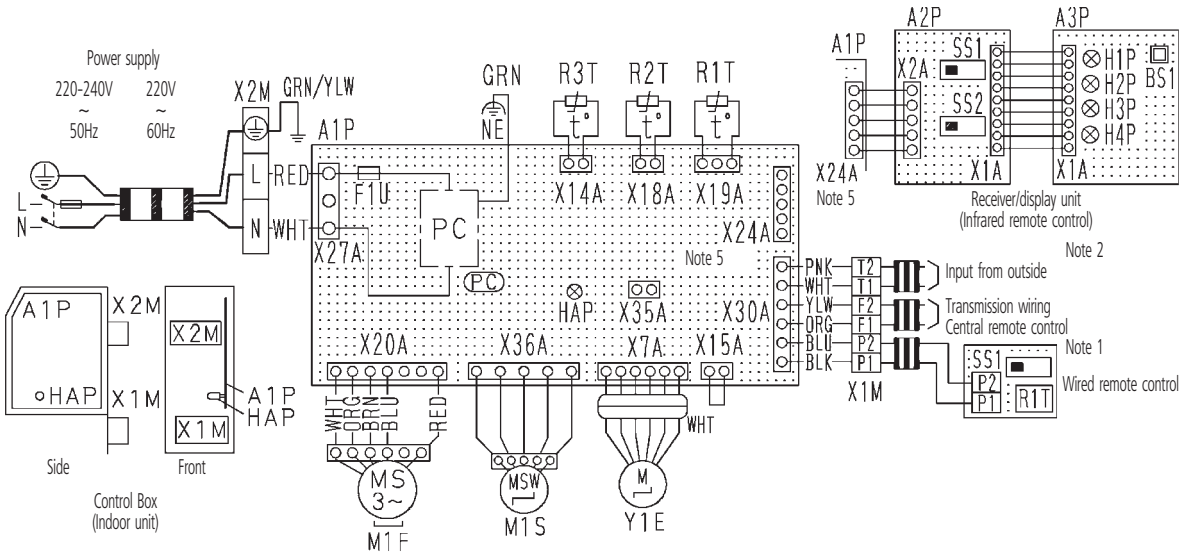

Indoor Unit					
A1P	Printed circuit board	Y1E	Electronic expansion valve	SS1	Selector switch (Main/sub)
F1U	Fuse (⊕, 3A, 250V)	PC	Power Circuit	SS2	Selector switch (Wireless address set)
HAP	Light emitting diode (Service monitor-green)	Receiver/display unit (Attached to infrared remote control)			
M1F	Motor (Indoor fan)	A2P	Printed circuit board		Wired remote control
M1S	Motor (Swing flap)	A3P	Printed circuit board	R1T	Thermistor (Air)
R1T	Thermistor (Air)	BS1	Push button (On/off)	SS1	Selector switch (Main/sub)
R2T	Thermistor (Coil liquid pipe)	H1P	Light emitting diode (On-red)		
R3T	Thermistor (Coil gas pipe)	H2P	Light emitting diode (Timer green)		Connector for optional parts
X1M	Terminal block (Control)	H3P	Light emitting diode (Filter sign-red)	X15A	Connector (Float switch)
X2M	Terminal block (Power)	H4P	Light emitting diode (Defrost-orange)	X35A	Connector (Group control adapter)

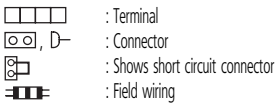

COLORS : BLK : Black PNK : Pink
 BLU : Blue RED : Red
 BRN : Brown WHT : White
 GRN : Green YLW : Yellow
 ORG : Orange

NOTES

- In case of using central remote control, connect it to the unit in accordance with the attached installation manual.
- When connecting the input wires from outside, forced off or on/off control operation can be selected by remote control. In details, refer to the installation manual attached the unit.
- Remote control model varies according to the combination system. Confirm engineering data and catalogs, etc. before connecting.
- Confirm the method of setting the selector switch (SS1, SS2) of wired remote control and infrared remote control by installation manual and engineering data, etc.
- X24A is connected when the infrared remote control kit is being used.

3D034206C

9 Sound data

9 - 1 Sound pressure spectrum

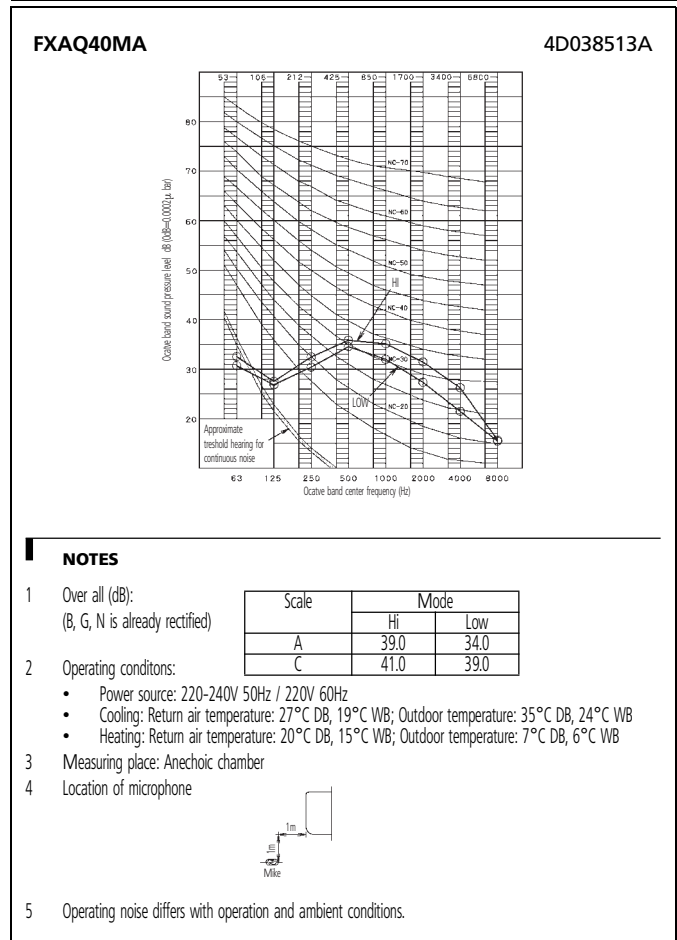
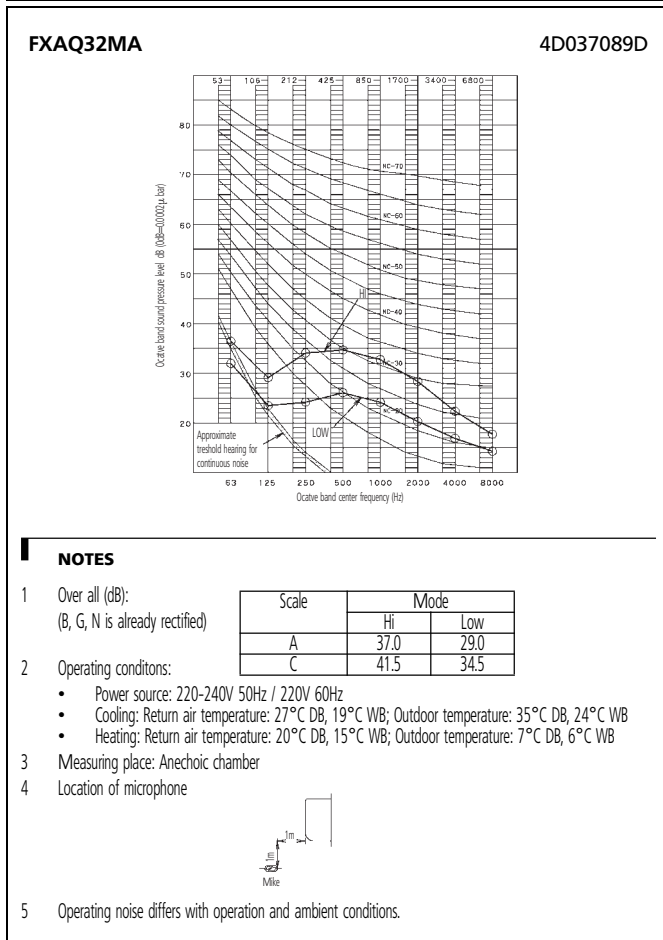
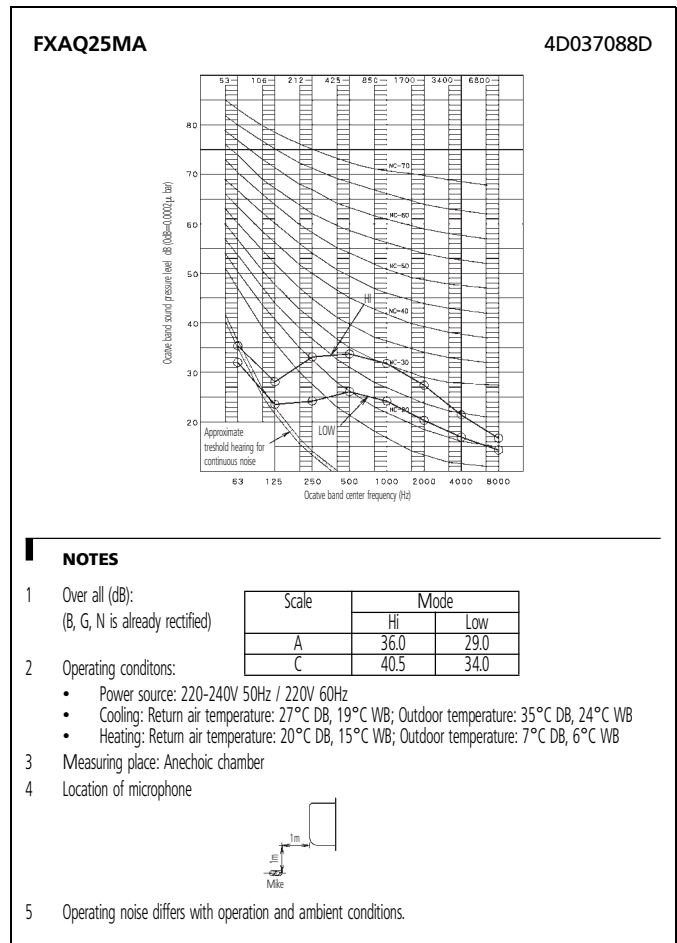
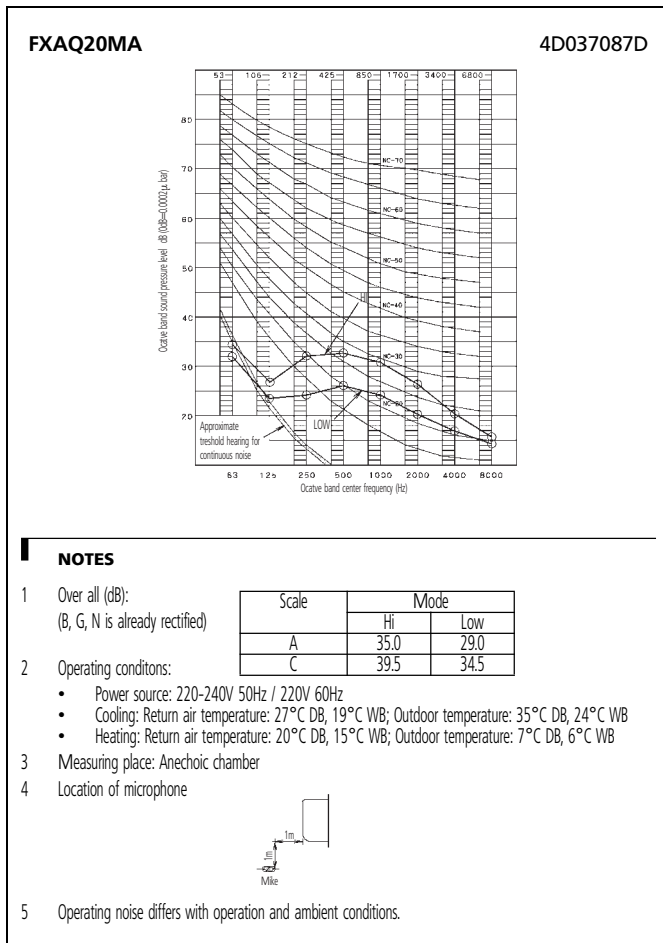

9 Sound data

9 - 1 Sound pressure spectrum

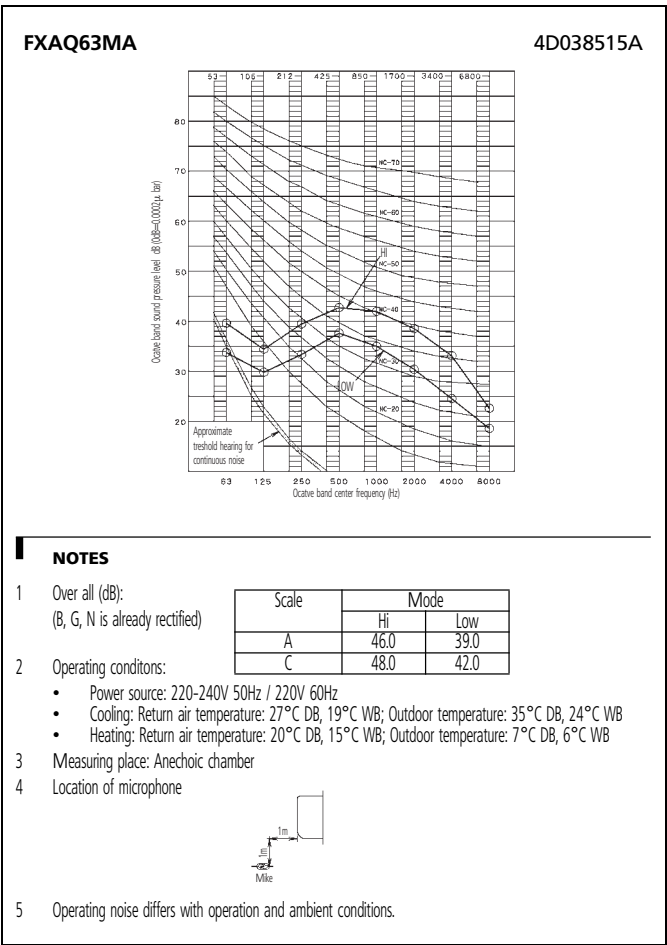
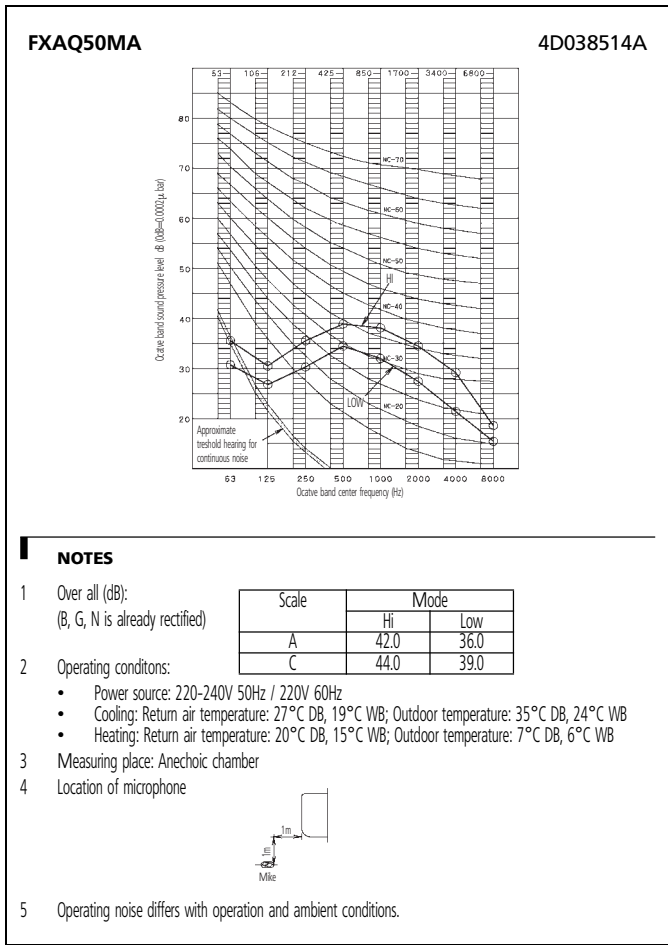

10 Installation

10 - 1 Service space

- 1 Select an installation site where the following conditions are fulfilled and that meets with your customer's approval.
 - In the upper space (including the back of the ceiling) of the indoor unit where there is no possible dripping of water from the refrigerant pipe, drain pipe, water pipe, etc.
 - Where the wall is strong enough to bear the indoor unit weight.
 - Where sufficient clearance for installation and maintenance can be ensured.
 - Where optimum air distribution can be ensured.
 - Where nothing blocks the air passage.
 - Where condensation can be properly drained.
 - Where the wall is not significantly tilted.
 - Where not exposed to combustible gases.
 - Where piping between indoor and outdoor units is possible within the allowable limit. (Refer to the installation manual of the outdoor unit.)
 - Keep the indoor and outdoor units, power cable and transmission wiring, at least 1 m from TVs and radios, to prevent distorted pictures and static. (Depending on the type and source of the electrical waves, static may be heard even when more than 1 m away.)
 - Install the indoor unit no less than 2.5 m above the floor. Where unavoidably lower, take what measures are necessary to keep hands out of the air inlet.

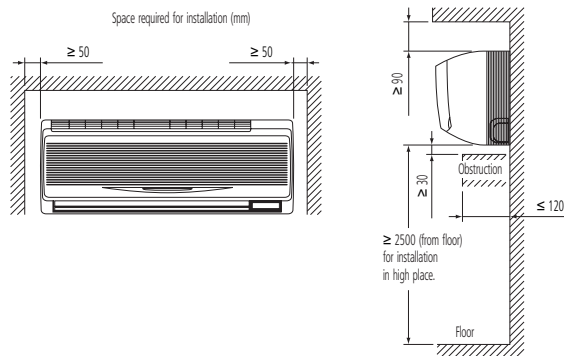

- 2 Consider whether the location where the unit will be installed can support the full weight of the unit, and reinforce it with boards and beams, etc. if needed before proceeding with the installation. Also, reinforce the location to prevent vibration and noise before installing.
- 3 The indoor unit may not be directly installed on the wall. Use the attached installation panel before installing the unit.

2e

VRV III-S
VRV III
VRV VII



In all of us,
a green heart

Daikin's unique position as a manufacturer of air conditioning equipment, compressors and refrigerants has led to its close involvement in environmental issues. For several years Daikin has had the intension to become a leader in the provision of products that have limited impact on the environment. This challenge demands the eco design and development of a wide range of products and an energy management system, resulting in energy conservation and a reduction of waste.



Daikin Europe N.V. is approved by LRQA for its Quality Management System in accordance with the ISO9001 standard. ISO9001 pertains to quality assurance regarding design, development, manufacturing as well as to services related to the product.



ISO14001 assures an effective environmental management system in order to help protect human health and the environment from the potential impact of our activities, products and services and to assist in maintaining and improving the quality of the environment.



Daikin units comply with the European regulations that guarantee the safety of the product.

VRV® products are not within the scope of the Eurovent certification programme.

The present publication is drawn up by way of information only and does not constitute an offer binding upon Daikin Europe N.V.. Daikin Europe N.V. has compiled the content of this publication to the best of its knowledge. No express or implied warranty is given for the completeness, accuracy, reliability or fitness for particular purpose of its content and the products and services presented therein. Specifications are subject to change without prior notice. Daikin Europe N.V. explicitly rejects any liability for any direct or indirect damage. In the broadest sense, arising from or related to the use and/or interpretation of this publication. All content is copyrighted by Daikin Europe N.V..

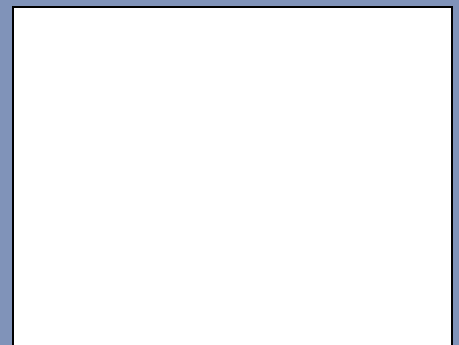

DAIKIN EUROPE N.V.

Naamloze Vennootschap
Zandvoordestraat 300
B-8400 Oostende, Belgium
www.daikin.eu
BTW: BE 0412 120 336
RPR Oostende



EEDEN08-204 • 01/2008 • Copyright © Daikin
The present publication supersedes EEDEN07-200
Prepared in Belgium by Lannoo (www.lannooprint.be), a company whose concern for the environment is set in the ENIAS and ISO 14001 systems.
Responsible Editor: Daikin Europe N.V., Zandvoordestraat 300, B- 8400 Oostende