



Air Conditioners

Technical Data



2-Way Blow Ceiling Mounted Cassette



www.daikin.eu

FXCQ-M8V3B

TABLE OF CONTENTS

FXCQ-M8V3B

1	Specifications	2
	Technical Specifications	2
	Electrical Specifications	6
2	Safety device settings	7
3	Options	7
4	Control systems	8
5	Capacity tables	9
	Cooling capacity tables	9
	Heating capacity tables	11
6	Dimensional drawing & centre of gravity	13
	Dimensional drawing	13
	Centre of gravity	16
7	Piping diagram.....	17
8	Wiring diagram.....	18
	Wiring diagram	18
9	Sound data	20
	Sound level data	20
	Sound pressure spectrum	21
10	Air flow pattern.....	23

1 Specifications

1-1 Technical Specifications				FXCQ20M8V3B	FXCQ25M8V3B	FXCQ32M8V3B	FXCQ40M8V3B	FXCQ50M8V3B	
Nominal Capacity	Cooling	kW		2.20	2.80	3.60	4.50	5.60	
	Heating	kW		2.50	3.20	4.00	5.00	6.30	
Power input (Nominal)	Cooling	kW		0.077	0.092	0.092	0.130	0.130	
	Heating	kW		0.044	0.059	0.059	0.097	0.097	
Casing	Colour	Non painted							
	Material	Galvanised steel							
Dimensions	Packing	Height	mm	405	405	405	405	405	
		Width	mm	1060	1060	1060	1280	1280	
		Depth	mm	665	665	665	665	665	
	Unit	Height	mm	305	305	305	305	305	
		Width	mm	780	780	780	995	995	
		Depth	mm	600	600	600	600	600	
Weight	Unit	kg		26	26	26	31	32	
	Packed Unit	kg		30	30	30	37	38	
Required Ceiling Void		mm		350	350	350	350	350	
Heat Exchanger	Dimensions	Length	mm	475 x 2	475 x 2	475 x 2	690 x 2	475 x 2	
		Nr of Rows	2 x 2						
		Fin Pitch	mm	1.50	1.50	1.50	1.50	1.50	
		Nr of Passes	3 x 2						
		Face Area	m ²	0.1 x 2	0.1 x 2	0.1 x 2	0.145 x 2	0.145 x 2	
		Nr of Stages	10 x 2						
		Empty Tubeplate Hole					6		
	Tube type	Hi-XSS (7)							
	Fin	Fin type	Symmetric waffle louvre						
		Treatment	Hydrophilic						
Fan	Type	Sirocco fan							
	Quantity			1	1	1	2	2	
Air Flow Rate	Cooling	High	m ³ /min	7.0	9.0	9.0	12.0	12.0	
		Low	m ³ /min	5.0	6.5	6.5	9.0	9.0	
	Heating	High	m ³ /min	7.0	9.0	9.0	12.0	12.0	
		Low	m ³ /min	5.0	6.5	6.5	9.0	9.0	
Fan	Motor	Quantity		1	1	1	1	1	
		Steps	Phase cut control						
		Output (high)	W	10	15	15	20	20	
		Drive	Direct drive						
Refrigerant	Name	R-410A							
Sound Level	Cooling	Sound power (nominal)	dBA	45.0	50.0	50.0	50.0	50.0	
Cooling	Sound Pressure	High	dBA	33.0	35.0	35.0	35.5	35.5	
		Low	dBA	28.0	29.0	29.0	30.5	30.5	
Heating	Sound Pressure	High	dBA	33.0	35.0	35.0	35.5	35.5	
		Low	dBA	28.0	29.0	29.0	30.5	30.5	
Piping connections	Liquid (OD)	Type	Flare connection						
		Diameter	mm	6.35	6.35	6.35	6.35	6.35	
	Gas	Type	Flare connection						
		Diameter	mm	12.7	12.7	12.7	12.7	12.7	
	Drain	Diameter	mm	32	32	32	32	32	
	Heat Insulation	Both liquid and gas pipes							
Decoration Panel	Model			BYBC32GJW1	BYBC32GJW1	BYBC32GJW1	BYBC50GJW1	BYBC50GJW1	
	Colour	White (10Y9/0,5)							
	Dimensions	Height	mm	53	53	53	53	53	
		Width	mm	1030	1030	1030	1245	1245	
		Depth	mm	680	680	680	680	680	
Weight	kg		8.0	8.0	8.0	8.5	8.5		
Drain-up Height		mm		600	600	600	600	600	
Air Filter	Resin net with mold resistance								
Air direction control	Up and downwards								
Refrigerant control	Electronic expansion valve								

1 Specifications

1-1 Technical Specifications		FXCQ20M8V3B	FXCQ25M8V3B	FXCQ32M8V3B	FXCQ40M8V3B	FXCQ50M8V3B
Temperature control		Microprocessor thermostat for cooling and heating				
Safety devices		PC board fuse				
		Fan motor thermal fuse				
		Drain pump fuse				
Standard Accessories	Standard Accessories	Screws for fixing the paper pattern for installation				
	Quantity	4	4	4	4	4
	Standard Accessories	Washer for hanging bracket				
	Quantity	8	8	8	8	8
	Standard Accessories	Clamps				
	Quantity	1	1	1	1	1
	Standard Accessories	Installation and operation manual				
	Quantity	1	1	1	1	1
	Standard Accessories	Paper pattern for installation				
	Quantity	1	1	1	1	1
	Standard Accessories	Insulation for fitting				
	Quantity	2	2	2	2	2
	Standard Accessories	Drain hose				
	Quantity	1	1	1	1	1
Notes		Nominal cooling capacities are based on : indoor temperature : 27°CDB, 19°CWB, outdoor temperature : 35°CDB, equivalent refrigerant piping : 8m, level difference : 0m.				
		Nominal heating capacities are based on : indoor temperature : 20°CDB, outdoor temperature : 7°CDB, 6°CWB, equivalent refrigerant piping : 8m, level difference : 0m.				
		Capacities are net, including a deduction for cooling (an addition for heating) for indoor fan motor heat.				

1 Specifications

1-1 Technical Specifications				FXCQ63M8V3B	FXCQ80M8V3B	FXCQ125M8V3B
Nominal Capacity	Cooling	kW		7.10	9.00	14.00
	Heating	kW		8.00	10.00	16.00
Power input (Nominal)	Cooling	kW		0.161	0.209	0.256
	Heating	kW		0.126	0.176	0.223
Casing	Colour	Non painted				
	Material	Galvanised steel				
Dimensions	Packing	Height	mm	405	405	405
		Width	mm	1460	1808	1808
		Depth	mm	665	645	645
	Unit	Height	mm	305	305	305
		Width	mm	1180	1670	1670
		Depth	mm	600	600	600
Weight	Unit	kg		35	47	48
	Packed Unit	kg		42	55	56
Required Ceiling Void		mm		350	350	350
Heat Exchanger	Dimensions	Length	mm	875 x 2		1365
		Nr of Rows		2 x 2		
		Fin Pitch	mm	1.50	1.50	1.50
		Nr of Passes		6 x 2		6
		Face Area	m ²	0.184 x 2		0.287 x 2
		Nr of Stages		10 x 2		
		Empty Tubeplate Hole			8	
	Tube type	Hi-XSS (7)				
	Fin	Fin type	Symmetric waffle louvre			
		Treatment	Hydrophilic			
Fan	Type	Sirocco fan				
	Quantity		2	3	3	
Air Flow Rate	Cooling	High	m ³ /min	16.5	26.0	33.0
		Low	m ³ /min	13.0	21.0	25.0
	Heating	High	m ³ /min	16.5	26.0	33.0
		Low	m ³ /min	13.0	21.0	25.0
Fan	Motor	Quantity		1	1	1
		Steps	Phase cut control			
	Output (high)	W	30	50	85	
	Drive	Direct drive				
Refrigerant	Name	R-410A				
Sound Level	Cooling	Sound power (nominal)	dB(A)	52.0	54.0	60.0
Cooling	Sound Pressure	High	dB(A)	38.0	40.0	45.0
		Low	dB(A)	33.0	35.0	39.0
Heating	Sound Pressure	High	dB(A)	38.0	40.0	45.0
		Low	dB(A)	33.0	35.0	39.0
Piping connections	Liquid (OD)	Type	Flare connection			
		Diameter	mm	9.5	9.5	9.5
	Gas	Type	Flare connection			
		Diameter	mm	15.9	15.9	15.9
	Drain	Diameter	mm	32	32	32
	Heat Insulation	Both liquid and gas pipes				
Decoration Panel	Model			BYBC63GJW1	BYBC125GJW1	BYBC125GJW1
	Colour	White (10Y9/0,5)				
	Dimensions	Height	mm	53	53	53
		Width	mm	1430	1920	1920
		Depth	mm	680	680	680
	Weight		kg	9.5	12.0	12.0
Drain-up Height		mm	600	600	600	
Air Filter	Resin net with mold resistance					
Air direction control	Up and downwards					
Refrigerant control	Electronic expansion valve					

1 Specifications

1-1 Technical Specifications		FXCQ63M8V3B	FXCQ80M8V3B	FXCQ125M8V3B
Temperature control		Microprocessor thermostat for cooling and heating		
Safety devices		PC board fuse		
		Fan motor thermal fuse	Fan motor thermal protector	Fan motor thermal protector
		Drain pump fuse		
Standard Accessories	Standard Accessories	Screws for fixing the paper pattern for installation		
	Quantity	4	4	4
	Standard Accessories	Washer for hanging bracket		
	Quantity	8	8	8
	Standard Accessories	Clamps		
	Quantity	1	1	1
	Standard Accessories	Installation and operation manual		
	Quantity	1	1	1
	Standard Accessories	Paper pattern for installation		
	Quantity	1	1	1
	Standard Accessories	Insulation for fitting		
	Quantity	2	2	2
	Standard Accessories	Drain hose		
	Quantity	1	1	1
Notes		Nominal cooling capacities are based on : indoor temperature : 27°CDB, 19°CWB, outdoor temperature : 35°CDB, equivalent refrigerant piping : 8m, level difference : 0m.		
		Nominal heating capacities are based on : indoor temperature : 20°CDB, outdoor temperature : 7°CDB, 6°CWB, equivalent refrigerant piping : 8m, level difference : 0m.		
		Capacities are net, including a deduction for cooling (an addition for heating) for indoor fan motor heat.		

1 Specifications

1-2 Electrical Specifications			FXCQ20M8V3B	FXCQ25M8V3B	FXCQ32M8V3B	FXCQ40M8V3B	FXCQ50M8V3B
Power Supply	Name		V3				
	Phase		1	1	1	1	1
	Frequency	Hz	50	50	50	50	50
	Voltage	V	230	230	230	230	230
Current	Minimum circuit amps (MCA)	A	0.50	0.50	0.50	0.80	0.80
	Maximum fuse amps (MFA)	A	16.00	16.00	16.00	16.00	16.00
	Full load amps (FLA)	A	0.40	0.40	0.40	0.60	0.60
Voltage range	Minimum	V	-10%				
	Maximum	V	+10%				
Power Supply Intake			Both indoor and outdoor unit				
Notes			Voltage range : units are suitable for use on electrical systems where voltage supplied to unit terminals is not below or above listed range limits.				
			Maximum allowable voltage range variation between phases is 2%.				
			MCA/MFA : MCA = 1.25 x FLA				
			MFA <= 4 x FLA				
			select wire size based on the MCA				
			instead of a fuse, use a circuit breaker				
			For more details concerning conditional connections, see http://extranet.daikineurope.com , select "E-Data Books". Finally, click on the document title of your choice.				

1-2 Electrical Specifications			FXCQ63M8V3B	FXCQ80M8V3B	FXCQ125M8V3B
Power Supply	Name		V3		
	Phase		1	1	1
	Frequency	Hz	50	50	50
	Voltage	V	230	230	230
Current	Minimum circuit amps (MCA)	A	0.90	1.10	1.30
	Maximum fuse amps (MFA)	A	16.00	16.00	16.00
	Full load amps (FLA)	A	0.70	0.90	1.00
Voltage range	Minimum	V	-10%		
	Maximum	V	+10%		
Power Supply Intake			Both indoor and outdoor unit		
Notes			Voltage range : units are suitable for use on electrical systems where voltage supplied to unit terminals is not below or above listed range limits.		
			Maximum allowable voltage range variation between phases is 2%.		
			MCA/MFA : MCA = 1.25 x FLA		
			MFA <= 4 x FLA		
			select wire size based on the MCA		
			instead of a fuse, use a circuit breaker		
			For more details concerning conditional connections, see http://extranet.daikineurope.com , select "E-Data Books". Finally, click on the document title of your choice.		

2 Safety device settings

	FXCQ20M8	FXCQ25M8	FXCQ32M8	FXCQ40M8	FXCQ50M8	FXCQ63M8	FXCQ80M8	FXCQ125M8	
PC BOARD FUSE	250V 5A								
FAN MOTOR THERMAL FUSE	°C	152 ^{±2}					-		
DRAIN PUMP FUSE	°C	164.5 ^{±2.5}							
FAN MOTOR THERMAL PROTECTOR	-						OFF: 135 ^{±8} (ON: 87 ^{±15})		
3TW25511-3									

3 Options

	FXCQ20M8	FXCQ25M8	FXCQ32M8	FXCQ40M8	FXCQ50M8	FXCQ63M8	FXCQ80M8	FXCQ125M8
DECORATION PANEL	BYBC32G		BYBC50G		BYBC63G	BYBC125G		
HIGH EFFICIENCY FILTER 65% (1)	KAFJ532G36		KAFJ532G56		KAFJ532G80	KAFJ532G160		
HIGH EFFICIENCY FILTER 90% (1)	KAFJ533G136		KAFJ533G56		KAFJ533G80	KAFJ533G160		
FILTER CHAMBER FOR BOTTOM SUCTION	KDDFJ53G36		KDDFJ53G56		KDDFJ53G80	KDDFJ53G160		
REPLACEMENT LONG LIFE FILTER	KAFJ531G136		KAFJ531G56		KAFJ531G80	KAFJ531G160		
3TW25519-1D								
NOTES								
1 Filter chamber is required if installing a high efficiency filter								

4 Control systems

Individual control systems

		FXCQ20M8	FXCQ25M8	FXCQ32M8	FXCQ40M8	FXCQ50M8	FXCQ63M8	FXCQ80M8	FXCQ125M8
WIRED REMOTE CONTROL		BRC1D52							
INFRARED REMOTE CONTROL	Heat pump	BRC7C62							
	Cooling only	BRC7C67							

Centralised control systems

		FXCQ20M8	FXCQ25M8	FXCQ32M8	FXCQ40M8	FXCQ50M8	FXCQ63M8	FXCQ80M8	FXCQ125M8
CENTRALISED REMOTE CONTROL		DCS302C51							
UNIFIED ON/OFF CONTROL		DCS301B51							
SCHEDULE TIMER		DST301B51							

Others

		FXCQ20M8	FXCQ25M8	FXCQ32M8	FXCQ40M8	FXCQ50M8	FXCQ63M8	FXCQ80M8	FXCQ125M8
WIRING ADAPTER (HOUR METER)		EKP1B2							
WIRING ADAPTER FOR ELECTRICAL APPENDICES (1)		KRP2A51 #							
WIRING ADAPTER FOR ELECTRICAL APPENDICES (2)		KRP4A51 #							
REMOTE SENSOR		KRCS01-1							
INSTALLATION BOX FOR ADAPTER PCB		KRP1B96 (1)(2)							
ELECTRICAL BOX WITH EARTH TERMINAL (3 BLOCKS)		KJB311A							
ELECTRICAL BOX WITH EARTH TERMINAL (2 BLOCKS)		KJB212A							
NOISE FILTER (FOR ELECTROMAGNETIC INTERFACE USE ONLY)		KEK26-1A							
EXTERNAL ADAPTER FOR OUTDOOR UNIT (INSTALLATION ON INDOOR UNIT)		DTA104A61 #							

3TW25519-1D

NOTES

- 1 Up to 2 adapters can be fixed for each installation box.
- 2 Only 1 installation box can be installed per indoor unit.
- 3 Installation box is necessary for each adapter marked with #.

5 Capacity tables

5 - 1 Cooling capacity tables

FXCQ-M8		TC: Total capacity/kW - SHC: Sensible capacity/kW														
Unit size	Nominal capacity	Outdoor air temp. °CDB	Indoor air temperature													
			14.0WB		16.0WB		18.0WB		19.0WB		20.0WB		22.0WB		24.0WB	
			20.0DB		23.0DB		26.0DB		27.0DB		28.0DB		30.0DB		32.0DB	
			TC	SHC	TC	SHC	TC	SHC	TC	SHC	TC	SHC	TC	SHC	TC	SHC
20	2.2	10.0	1.5	1.4	1.8	1.5	2.1	1.7	2.2	1.7	2.3	1.8	2.6	1.7	2.9	1.7
		12.0	1.5	1.4	1.8	1.5	2.1	1.7	2.2	1.7	2.3	1.8	2.6	1.7	2.9	1.7
		14.0	1.5	1.4	1.8	1.5	2.1	1.7	2.2	1.7	2.3	1.8	2.6	1.7	2.8	1.7
		16.0	1.5	1.4	1.8	1.5	2.1	1.7	2.2	1.7	2.3	1.8	2.6	1.7	2.8	1.7
		18.0	1.5	1.4	1.8	1.5	2.1	1.7	2.2	1.7	2.3	1.8	2.6	1.7	2.7	1.7
		20.0	1.5	1.4	1.8	1.5	2.1	1.7	2.2	1.7	2.3	1.8	2.6	1.7	2.7	1.6
		21.0	1.5	1.4	1.8	1.5	2.1	1.7	2.2	1.7	2.3	1.8	2.6	1.7	2.7	1.6
		23.0	1.5	1.4	1.8	1.5	2.1	1.7	2.2	1.7	2.3	1.8	2.6	1.7	2.6	1.6
		25.0	1.5	1.4	1.8	1.5	2.1	1.7	2.2	1.7	2.3	1.8	2.6	1.7	2.6	1.6
		27.0	1.5	1.4	1.8	1.5	2.1	1.7	2.2	1.7	2.3	1.8	2.5	1.7	2.6	1.6
		29.0	1.5	1.4	1.8	1.5	2.1	1.7	2.2	1.7	2.3	1.8	2.5	1.7	2.5	1.6
		31.0	1.5	1.4	1.8	1.5	2.1	1.7	2.2	1.7	2.3	1.8	2.4	1.7	2.5	1.5
		33.0	1.5	1.4	1.8	1.5	2.1	1.7	2.2	1.7	2.3	1.8	2.4	1.6	2.5	1.5
35.0	1.5	1.4	1.8	1.5	2.1	1.7	2.2	1.7	2.3	1.7	2.4	1.6	2.4	1.5		
37.0	1.5	1.4	1.8	1.5	2.1	1.7	2.2	1.7	2.3	1.7	2.3	1.6	2.4	1.5		
39.0	1.5	1.4	1.8	1.5	2.1	1.7	2.2	1.7	2.2	1.7	2.3	1.6	2.3	1.5		
25	2.8	10.0	1.9	1.7	2.3	1.9	2.6	2.1	2.8	2.2	3.0	2.2	3.4	2.2	3.7	2.2
		12.0	1.9	1.7	2.3	1.9	2.6	2.1	2.8	2.2	3.0	2.2	3.4	2.2	3.6	2.2
		14.0	1.9	1.7	2.3	1.9	2.6	2.1	2.8	2.2	3.0	2.2	3.4	2.2	3.6	2.2
		16.0	1.9	1.7	2.3	1.9	2.6	2.1	2.8	2.2	3.0	2.2	3.4	2.2	3.5	2.2
		18.0	1.9	1.7	2.3	1.9	2.6	2.1	2.8	2.2	3.0	2.2	3.4	2.2	3.5	2.1
		20.0	1.9	1.7	2.3	1.9	2.6	2.1	2.8	2.2	3.0	2.2	3.4	2.2	3.4	2.1
		21.0	1.9	1.7	2.3	1.9	2.6	2.1	2.8	2.2	3.0	2.2	3.4	2.2	3.4	2.1
		23.0	1.9	1.7	2.3	1.9	2.6	2.1	2.8	2.2	3.0	2.2	3.3	2.2	3.4	2.1
		25.0	1.9	1.7	2.3	1.9	2.6	2.1	2.8	2.2	3.0	2.2	3.3	2.2	3.3	2.1
		27.0	1.9	1.7	2.3	1.9	2.6	2.1	2.8	2.2	3.0	2.2	3.2	2.2	3.3	2.0
		29.0	1.9	1.7	2.3	1.9	2.6	2.1	2.8	2.2	3.0	2.2	3.2	2.1	3.2	2.0
		31.0	1.9	1.7	2.3	1.9	2.6	2.1	2.8	2.2	3.0	2.2	3.1	2.1	3.2	2.0
		33.0	1.9	1.7	2.3	1.9	2.6	2.1	2.8	2.2	3.0	2.2	3.1	2.1	3.1	2.0
35.0	1.9	1.7	2.3	1.9	2.6	2.1	2.8	2.2	3.0	2.2	3.0	2.1	3.1	1.9		
37.0	1.9	1.7	2.3	1.9	2.6	2.1	2.8	2.2	2.9	2.2	3.0	2.0	3.0	1.9		
39.0	1.9	1.7	2.3	1.9	2.6	2.1	2.8	2.2	2.9	2.2	2.9	2.0	3.0	1.9		
32	3.6	10.0	2.4	2.1	2.9	2.3	3.4	2.5	3.6	2.6	3.8	2.6	4.3	2.7	4.7	2.7
		12.0	2.4	2.1	2.9	2.3	3.4	2.5	3.6	2.6	3.8	2.6	4.3	2.7	4.7	2.7
		14.0	2.4	2.1	2.9	2.3	3.4	2.5	3.6	2.6	3.8	2.6	4.3	2.7	4.6	2.7
		16.0	2.4	2.1	2.9	2.3	3.4	2.5	3.6	2.6	3.8	2.6	4.3	2.7	4.6	2.6
		18.0	2.4	2.1	2.9	2.3	3.4	2.5	3.6	2.6	3.8	2.6	4.3	2.7	4.5	2.6
		20.0	2.4	2.1	2.9	2.3	3.4	2.5	3.6	2.6	3.8	2.6	4.3	2.7	4.4	2.5
		21.0	2.4	2.1	2.9	2.3	3.4	2.5	3.6	2.6	3.8	2.6	4.3	2.7	4.4	2.5
		23.0	2.4	2.1	2.9	2.3	3.4	2.5	3.6	2.6	3.8	2.6	4.2	2.6	4.3	2.5
		25.0	2.4	2.1	2.9	2.3	3.4	2.5	3.6	2.6	3.8	2.6	4.2	2.6	4.3	2.5
		27.0	2.4	2.1	2.9	2.3	3.4	2.5	3.6	2.6	3.8	2.6	4.1	2.6	4.2	2.4
		29.0	2.4	2.1	2.9	2.3	3.4	2.5	3.6	2.6	3.8	2.6	4.1	2.5	4.2	2.4
		31.0	2.4	2.1	2.9	2.3	3.4	2.5	3.6	2.6	3.8	2.6	4.0	2.5	4.1	2.4
		33.0	2.4	2.1	2.9	2.3	3.4	2.5	3.6	2.6	3.8	2.6	4.0	2.5	4.0	2.4
35.0	2.4	2.1	2.9	2.3	3.4	2.5	3.6	2.6	3.8	2.6	3.9	2.5	4.0	2.4		
37.0	2.4	2.1	2.9	2.3	3.4	2.5	3.6	2.6	3.7	2.6	3.8	2.5	3.9	2.3		
39.0	2.4	2.1	2.9	2.3	3.4	2.5	3.6	2.6	3.7	2.6	3.8	2.4	3.8	2.3		
40	4.5	10.0	3.0	2.5	3.6	2.8	4.2	3.1	4.5	3.2	4.8	3.3	5.4	3.3	5.9	3.3
		12.0	3.0	2.5	3.6	2.8	4.2	3.1	4.5	3.2	4.8	3.3	5.4	3.3	5.8	3.3
		14.0	3.0	2.5	3.6	2.8	4.2	3.1	4.5	3.2	4.8	3.3	5.4	3.3	5.8	3.2
		16.0	3.0	2.5	3.6	2.8	4.2	3.1	4.5	3.2	4.8	3.3	5.4	3.3	5.7	3.2
		18.0	3.0	2.5	3.6	2.8	4.2	3.1	4.5	3.2	4.8	3.3	5.4	3.3	5.6	3.2
		20.0	3.0	2.5	3.6	2.8	4.2	3.1	4.5	3.2	4.8	3.3	5.4	3.3	5.5	3.1
		21.0	3.0	2.5	3.6	2.8	4.2	3.1	4.5	3.2	4.8	3.3	5.4	3.3	5.5	3.1
		23.0	3.0	2.5	3.6	2.8	4.2	3.1	4.5	3.2	4.8	3.3	5.3	3.3	5.4	3.1
		25.0	3.0	2.5	3.6	2.8	4.2	3.1	4.5	3.2	4.8	3.3	5.2	3.3	5.3	3.1
		27.0	3.0	2.5	3.6	2.8	4.2	3.1	4.5	3.2	4.8	3.3	5.2	3.2	5.3	3.0
		29.0	3.0	2.5	3.6	2.8	4.2	3.1	4.5	3.2	4.8	3.3	5.1	3.2	5.2	3.0
		31.0	3.0	2.5	3.6	2.8	4.2	3.1	4.5	3.2	4.8	3.3	5.0	3.1	5.1	2.9
		33.0	3.0	2.5	3.6	2.8	4.2	3.1	4.5	3.2	4.8	3.3	4.9	3.1	5.0	2.9
35.0	3.0	2.5	3.6	2.8	4.2	3.1	4.5	3.2	4.7	3.3	4.9	3.1	5.0	2.9		
37.0	3.0	2.5	3.6	2.8	4.2	3.1	4.5	3.2	4.7	3.2	4.8	3.0	4.9	2.8		
39.0	3.0	2.5	3.6	2.8	4.2	3.1	4.5	3.2	4.6	3.2	4.7	3.0	4.8	2.8		

3TW25512-1

5 Capacity tables

5 - 1 Cooling capacity tables

FXCQ-M8		TC: Total capacity,kW – SHC: Sensible capacity,kW														
Unit size	Nominal capacity	Outdoor air temp. °CDB	Indoor air temperature													
			14.OWB		16.OWB		18.OWB		19.OWB		20.OWB		22.OWB		24.OWB	
			20.0DB	23.0DB	26.0DB	27.0DB	28.0DB	30.0DB	32.0DB	TC	SHC	TC	SHC	TC	SHC	TC
50	5.6	10.0	3.8	3.1	4.5	3.4	5.2	3.8	5.6	3.9	6.0	4.0	6.7	4.1	7.4	4.0
		12.0	3.8	3.1	4.5	3.4	5.2	3.8	5.6	3.9	6.0	4.0	6.7	4.1	7.3	4.0
		14.0	3.8	3.1	4.5	3.4	5.2	3.8	5.6	3.9	6.0	4.0	6.7	4.1	7.2	4.0
		16.0	3.8	3.1	4.5	3.4	5.2	3.8	5.6	3.9	6.0	4.0	6.7	4.1	7.1	3.9
		18.0	3.8	3.1	4.5	3.4	5.2	3.8	5.6	3.9	6.0	4.0	6.7	4.1	7.0	3.9
		20.0	3.8	3.1	4.5	3.4	5.2	3.8	5.6	3.9	6.0	4.0	6.7	4.1	6.9	3.8
		21.0	3.8	3.1	4.5	3.4	5.2	3.8	5.6	3.9	6.0	4.0	6.7	4.1	6.8	3.8
		23.0	3.8	3.1	4.5	3.4	5.2	3.8	5.6	3.9	6.0	4.0	6.6	4.0	6.7	3.8
		25.0	3.8	3.1	4.5	3.4	5.2	3.8	5.6	3.9	6.0	4.0	6.5	4.0	6.6	3.7
		27.0	3.8	3.1	4.5	3.4	5.2	3.8	5.6	3.9	6.0	4.0	6.4	3.9	6.6	3.7
		29.0	3.8	3.1	4.5	3.4	5.2	3.8	5.6	3.9	6.0	4.0	6.3	3.9	6.5	3.6
		31.0	3.8	3.1	4.5	3.4	5.2	3.8	5.6	3.9	6.0	4.0	6.2	3.8	6.4	3.6
		33.0	3.8	3.1	4.5	3.4	5.2	3.8	5.6	3.9	6.0	4.0	6.1	3.8	6.3	3.6
		35.0	3.8	3.1	4.5	3.4	5.2	3.8	5.6	3.9	5.9	4.0	6.0	3.8	6.2	3.5
37.0	3.8	3.1	4.5	3.4	5.2	3.8	5.6	3.9	5.8	3.9	5.9	3.7	6.1	3.5		
39.0	3.8	3.1	4.5	3.4	5.2	3.8	5.6	3.9	5.7	3.9	5.8	3.7	6.0	3.4		
63	7.1	10.0	4.8	3.8	5.7	4.2	6.6	4.7	7.1	4.9	7.6	4.9	8.5	5.0	9.3	5.0
		12.0	4.8	3.8	5.7	4.2	6.6	4.7	7.1	4.9	7.6	4.9	8.5	5.0	9.2	5.0
		14.0	4.8	3.8	5.7	4.2	6.6	4.7	7.1	4.9	7.6	4.9	8.5	5.0	9.1	4.9
		16.0	4.8	3.8	5.7	4.2	6.6	4.7	7.1	4.9	7.6	4.9	8.5	5.0	9.0	4.9
		18.0	4.8	3.8	5.7	4.2	6.6	4.7	7.1	4.9	7.6	4.9	8.5	5.0	8.8	4.8
		20.0	4.8	3.8	5.7	4.2	6.6	4.7	7.1	4.9	7.6	4.9	8.5	5.0	8.7	4.7
		21.0	4.8	3.8	5.7	4.2	6.6	4.7	7.1	4.9	7.6	4.9	8.5	5.0	8.7	4.7
		23.0	4.8	3.8	5.7	4.2	6.6	4.7	7.1	4.9	7.6	4.9	8.4	4.9	8.5	4.6
		25.0	4.8	3.8	5.7	4.2	6.6	4.7	7.1	4.9	7.6	4.9	8.3	4.9	8.4	4.6
		27.0	4.8	3.8	5.7	4.2	6.6	4.7	7.1	4.9	7.6	4.9	8.1	4.8	8.3	4.5
		29.0	4.8	3.8	5.7	4.2	6.6	4.7	7.1	4.9	7.6	4.9	8.0	4.7	8.2	4.5
		31.0	4.8	3.8	5.7	4.2	6.6	4.7	7.1	4.9	7.6	4.9	7.9	4.7	8.1	4.4
		33.0	4.8	3.8	5.7	4.2	6.6	4.7	7.1	4.9	7.6	4.9	7.8	4.6	7.9	4.4
		35.0	4.8	3.8	5.7	4.2	6.6	4.7	7.1	4.9	7.5	4.8	7.7	4.6	7.8	4.4
37.0	4.8	3.8	5.7	4.2	6.6	4.7	7.1	4.9	7.4	4.8	7.5	4.5	7.7	4.3		
39.0	4.8	3.8	5.7	4.2	6.6	4.7	7.1	4.9	7.2	4.7	7.4	4.5	7.6	4.3		
80	9.0	10.0	6.1	5.2	7.2	5.7	8.4	6.2	9.0	6.3	9.6	6.5	10.8	6.8	11.8	6.7
		12.0	6.1	5.2	7.2	5.7	8.4	6.2	9.0	6.3	9.6	6.5	10.8	6.8	11.7	6.6
		14.0	6.1	5.2	7.2	5.7	8.4	6.2	9.0	6.3	9.6	6.5	10.8	6.8	11.5	6.6
		16.0	6.1	5.2	7.2	5.7	8.4	6.2	9.0	6.3	9.6	6.5	10.8	6.8	11.4	6.5
		18.0	6.1	5.2	7.2	5.7	8.4	6.2	9.0	6.3	9.6	6.5	10.8	6.8	11.2	6.4
		20.0	6.1	5.2	7.2	5.7	8.4	6.2	9.0	6.3	9.6	6.5	10.8	6.8	11.1	6.3
		21.0	6.1	5.2	7.2	5.7	8.4	6.2	9.0	6.3	9.6	6.5	10.8	6.8	11.0	6.3
		23.0	6.1	5.2	7.2	5.7	8.4	6.2	9.0	6.3	9.6	6.5	10.6	6.7	10.8	6.3
		25.0	6.1	5.2	7.2	5.7	8.4	6.2	9.0	6.3	9.6	6.5	10.5	6.6	10.7	6.2
		27.0	6.1	5.2	7.2	5.7	8.4	6.2	9.0	6.3	9.6	6.5	10.3	6.6	10.5	6.1
		29.0	6.1	5.2	7.2	5.7	8.4	6.2	9.0	6.3	9.6	6.5	10.2	6.5	10.4	6.0
		31.0	6.1	5.2	7.2	5.7	8.4	6.2	9.0	6.3	9.6	6.5	10.0	6.4	10.2	6.0
		33.0	6.1	5.2	7.2	5.7	8.4	6.2	9.0	6.3	9.6	6.5	9.8	6.3	10.1	5.9
		35.0	6.1	5.2	7.2	5.7	8.4	6.2	9.0	6.3	9.5	6.4	9.7	6.3	9.9	5.8
37.0	6.1	5.2	7.2	5.7	8.4	6.2	9.0	6.3	9.3	6.4	9.5	6.2	9.8	5.7		
39.0	6.1	5.2	7.2	5.7	8.4	6.2	9.0	6.3	9.2	6.3	9.4	6.1	9.6	5.7		
125	14.0	10.0	9.5	7.8	11.3	8.6	13.1	9.5	14.0	9.7	14.9	9.9	16.8	10.2	18.4	10.3
		12.0	9.5	7.8	11.3	8.6	13.1	9.5	14.0	9.7	14.9	9.9	16.8	10.2	18.2	10.2
		14.0	9.5	7.8	11.3	8.6	13.1	9.5	14.0	9.7	14.9	9.9	16.8	10.2	18.0	10.1
		16.0	9.5	7.8	11.3	8.6	13.1	9.5	14.0	9.7	14.9	9.9	16.8	10.2	17.7	9.9
		18.0	9.5	7.8	11.3	8.6	13.1	9.5	14.0	9.7	14.9	9.9	16.8	10.2	17.5	9.8
		20.0	9.5	7.8	11.3	8.6	13.1	9.5	14.0	9.7	14.9	9.9	16.8	10.2	17.2	9.7
		21.0	9.5	7.8	11.3	8.6	13.1	9.5	14.0	9.7	14.9	9.9	16.8	10.2	17.1	9.6
		23.0	9.5	7.8	11.3	8.6	13.1	9.5	14.0	9.7	14.9	9.9	16.5	10.1	16.9	9.5
		25.0	9.5	7.8	11.3	8.6	13.1	9.5	14.0	9.7	14.9	9.9	16.3	10.0	16.6	9.4
		27.0	9.5	7.8	11.3	8.6	13.1	9.5	14.0	9.7	14.9	9.9	16.1	9.8	16.4	9.3
		29.0	9.5	7.8	11.3	8.6	13.1	9.5	14.0	9.7	14.9	9.9	15.8	9.7	16.2	9.3
		31.0	9.5	7.8	11.3	8.6	13.1	9.5	14.0	9.7	14.9	9.9	15.6	9.6	15.9	9.2
		33.0	9.5	7.8	11.3	8.6	13.1	9.5	14.0	9.7	14.9	9.9	15.3	9.5	15.7	9.1
		35.0	9.5	7.8	11.3	8.6	13.1	9.5	14.0	9.7	14.8	9.9	15.1	9.4	15.4	9.0
37.0	9.5	7.8	11.3	8.6	13.1	9.5	14.0	9.7	14.5	9.7	14.9	9.3	15.2	8.9		
39.0	9.5	7.8	11.3	8.6	13.1	9.5	14.0	9.8	14.3	9.6	14.6	9.2	15.0	8.8		

3TW25512-1

5 Capacity tables

5 - 2 Heating capacity tables

FXCQ-M8				Indoor air temp.: °CDB					
Unit size	Nominal Capacity	Outdoor air temp		16.0	18.0	20.0	21.0	22.0	24.0
		°CDB	°CWB	KW	KW	KW	KW	KW	KW
20	2.5	-19.8	-20.0	1.5	1.5	1.5	1.5	1.5	1.5
		-18.8	-19.0	1.5	1.5	1.5	1.5	1.5	1.5
		-16.7	-17.0	1.6	1.6	1.6	1.6	1.6	1.6
		-14.7	-15.0	1.7	1.7	1.7	1.7	1.7	1.7
		-12.6	-13.0	1.8	1.8	1.8	1.8	1.8	1.8
		-10.5	-11.0	1.9	1.9	1.9	1.9	1.9	1.9
		-9.5	-10.0	1.9	1.9	1.9	1.9	1.9	1.9
		-8.5	-9.1	2.0	2.0	1.9	1.9	1.9	1.9
		-7.0	-7.6	2.0	2.0	2.0	2.0	2.0	2.0
		-5.0	-5.6	2.1	2.1	2.1	2.1	2.1	2.1
		-3.0	-3.7	2.2	2.2	2.2	2.2	2.2	2.2
		0.0	-0.7	2.3	2.3	2.3	2.3	2.3	2.3
		3.0	2.2	2.5	2.5	2.4	2.4	2.3	2.2
		5.0	4.1	2.5	2.5	2.5	2.4	2.3	2.2
		7.0	6.0	2.6	2.6	2.5	2.4	2.3	2.2
		9.0	7.9	2.7	2.7	2.5	2.4	2.3	2.2
		11.0	9.6	2.8	2.7	2.5	2.4	2.3	2.2
13.0	11.8	2.8	2.7	2.5	2.4	2.3	2.2		
15.0	13.7	2.8	2.7	2.5	2.4	2.3	2.2		
25	3.2	-19.8	-20.0	1.9	1.9	1.9	1.9	1.9	1.9
		-18.8	-19.0	1.9	1.9	1.9	1.9	1.9	1.9
		-16.7	-17.0	2.1	2.1	2.0	2.0	2.0	2.0
		-14.7	-15.0	2.2	2.2	2.2	2.2	2.2	2.1
		-12.6	-13.0	2.3	2.3	2.3	2.3	2.3	2.3
		-10.5	-11.0	2.4	2.4	2.4	2.4	2.4	2.4
		-9.5	-10.0	2.5	2.4	2.4	2.4	2.4	2.4
		-8.5	-9.1	2.5	2.5	2.5	2.5	2.5	2.5
		-7.0	-7.6	2.6	2.6	2.6	2.6	2.6	2.6
		-5.0	-5.6	2.7	2.7	2.7	2.7	2.7	2.7
		-3.0	-3.7	2.8	2.8	2.8	2.8	2.8	2.8
		0.0	-0.7	3.0	3.0	3.0	3.0	3.0	2.6
		3.0	2.2	3.1	3.1	3.1	3.1	3.0	2.8
		5.0	4.1	3.3	3.2	3.2	3.1	3.0	2.8
		7.0	6.0	3.4	3.4	3.2	3.1	3.0	2.8
		9.0	7.9	3.5	3.4	3.2	3.1	3.0	2.8
		11.0	9.8	3.6	3.4	3.2	3.1	3.0	2.8
13.0	11.8	3.6	3.4	3.2	3.1	3.0	2.8		
15.0	13.7	3.6	3.4	3.2	3.1	3.0	2.8		
32	4.0	-19.8	-20.0	2.4	2.4	2.3	2.3	2.3	2.3
		-18.8	-19.0	2.4	2.4	2.4	2.4	2.4	2.4
		-16.7	-17.0	2.6	2.6	2.6	2.6	2.6	2.5
		-14.7	-15.0	2.7	2.7	2.7	2.7	2.7	2.7
		-12.6	-13.0	2.9	2.8	2.8	2.8	2.8	2.8
		-10.5	-11.0	3.0	3.0	3.0	3.0	3.0	3.0
		-9.5	-10.0	3.1	3.1	3.1	3.1	3.0	3.0
		-8.5	-9.1	3.1	3.1	3.1	3.1	3.1	3.1
		-7.0	-7.6	3.2	3.2	3.2	3.2	3.2	3.2
		-5.0	-5.6	3.4	3.4	3.4	3.4	3.4	3.4
		-3.0	-3.7	3.5	3.5	3.5	3.5	3.5	3.5
		0.0	-0.7	3.7	3.7	3.7	3.7	3.7	3.5
		3.0	2.2	3.9	3.9	3.9	3.9	3.7	3.5
		5.0	4.1	4.1	4.1	4.0	3.9	3.7	3.5
		7.0	6.0	4.2	4.2	4.0	3.9	3.7	3.5
		9.0	7.9	4.3	4.3	4.0	3.9	3.7	3.5
		11.0	9.8	4.5	4.3	4.0	3.9	3.7	3.5
13.0	11.8	4.5	4.3	4.0	3.9	3.7	3.5		
15.0	13.7	4.5	4.3	4.0	3.9	3.7	3.5		
40	5.0	-19.8	-20.0	3.0	2.9	2.9	2.9	2.9	2.9
		-18.8	-19.0	3.0	3.0	3.0	3.0	3.0	3.0
		-16.7	-17.0	3.2	3.2	3.2	3.2	3.2	3.2
		-14.7	-15.0	3.4	3.4	3.4	3.4	3.4	3.4
		-12.6	-13.0	3.6	3.6	3.6	3.5	3.5	3.5
		-10.5	-11.0	3.7	3.7	3.7	3.7	3.7	3.7
		-9.5	-10.0	3.8	3.8	3.8	3.8	3.8	3.8
		-8.5	-9.1	3.9	3.9	3.9	3.9	3.9	3.9
		-7.0	-7.6	4.0	4.0	4.0	4.0	4.0	4.0
		-5.0	-5.6	4.2	4.2	4.2	4.2	4.2	4.2
		-3.0	-3.7	4.4	4.4	4.4	4.4	4.4	4.4
		0.0	-0.7	4.7	4.6	4.6	4.6	4.4	4.4
		3.0	2.2	4.9	4.9	4.9	4.8	4.7	4.4
		5.0	4.1	5.1	5.1	5.0	4.8	4.7	4.4
		7.0	6.0	5.2	5.2	5.0	4.8	4.7	4.4
		9.0	7.9	5.4	5.3	5.0	4.8	4.7	4.4
		11.0	9.8	5.6	5.3	5.0	4.8	4.7	4.4
13.0	11.8	5.6	5.3	5.0	4.8	4.7	4.4		
15.0	13.7	5.6	5.3	5.0	4.8	4.7	4.4		

3TW25512-2A

5 Capacity tables

5 - 2 Heating capacity tables

FXCQ-M8				Indoor air temp.: °CDB					
Unit size	Nominal Capacity	Outdoor air temp		16.0	18.0	20.0	21.0	22.0	24.0
		°CDB	°CWB	KW	KW	KW	KW	KW	KW
50	6.3	-19.8	-20.0	3.7	3.7	3.7	3.7	3.7	3.7
		-18.8	-19.0	3.8	3.8	3.8	3.8	3.8	3.8
		-16.7	-17.0	4.1	4.0	4.0	4.0	4.0	4.0
		-14.7	-15.0	4.3	4.3	4.3	4.2	4.2	4.2
		-12.6	-13.0	4.5	4.5	4.5	4.5	4.5	4.5
		-10.5	-11.0	4.7	4.7	4.7	4.7	4.7	4.7
		-9.5	-10.0	4.8	4.8	4.8	4.8	4.8	4.8
		-8.5	-9.1	4.9	4.9	4.9	4.9	4.9	4.9
		-7.0	-7.6	5.1	5.1	5.1	5.1	5.1	5.1
		-5.0	-5.6	5.3	5.3	5.3	5.3	5.3	5.3
		-3.0	-3.7	5.5	5.5	5.5	5.5	5.5	5.5
		0.0	-0.7	5.9	5.9	5.8	5.8	5.8	5.5
		3.0	2.2	6.2	6.2	6.2	6.1	5.9	5.5
		5.0	4.1	6.4	6.4	6.3	6.1	5.9	5.5
		7.0	6.0	6.6	6.6	6.3	6.1	5.9	5.5
		9.0	7.9	6.8	6.7	6.3	6.1	5.9	5.5
		11.0	9.8	7.0	6.7	6.3	6.1	5.9	5.5
13.0	11.8	7.1	6.7	6.3	6.1	5.9	5.5		
15.0	13.7	7.1	6.7	6.3	6.1	5.9	5.5		
63	8.0	-19.8	-20.0	4.7	4.7	4.7	4.7	4.7	4.7
		-18.8	-19.0	4.9	4.9	4.8	4.8	4.8	4.8
		-16.7	-17.0	5.1	5.1	5.1	5.1	5.1	5.1
		-14.7	-15.0	5.4	5.4	5.4	5.4	5.4	5.4
		-12.6	-13.0	5.7	5.7	5.7	5.7	5.7	5.7
		-10.5	-11.0	6.0	6.0	6.0	6.0	6.0	6.0
		-9.5	-10.0	6.1	6.1	6.1	6.1	6.1	6.1
		-8.5	-9.1	6.3	6.3	6.2	6.2	6.2	6.2
		-7.0	-7.6	6.5	6.5	6.4	6.4	6.4	6.4
		-5.0	-5.6	6.8	6.7	6.7	6.7	6.7	6.7
		-3.0	-3.7	7.0	7.0	7.0	7.0	7.0	7.0
		0.0	-0.7	7.5	7.4	7.4	7.4	7.4	7.0
		3.0	2.2	7.9	7.8	7.8	7.7	7.5	7.0
		5.0	4.1	8.1	8.1	8.0	7.7	7.5	7.0
		7.0	6.0	8.4	8.4	8.0	7.7	7.5	7.0
		9.0	7.9	8.7	8.5	8.0	7.7	7.5	7.0
		11.0	9.8	8.9	8.5	8.0	7.7	7.5	7.0
13.0	11.8	9.0	8.5	8.0	7.7	7.5	7.0		
15.0	13.7	9.0	8.5	8.0	7.7	7.5	7.0		
80	10.0	-19.8	-20.0	5.9	5.9	5.9	5.9	5.9	5.8
		-18.8	-19.0	6.1	6.1	6.0	6.0	6.0	6.0
		-16.7	-17.0	6.4	6.4	6.4	6.4	6.4	6.4
		-14.7	-15.0	6.8	6.8	6.8	6.7	6.7	6.7
		-12.6	-13.0	7.1	7.1	7.1	7.1	7.1	7.1
		-10.5	-11.0	7.5	7.5	7.5	7.5	7.4	7.4
		-9.5	-10.0	7.7	7.7	7.6	7.6	7.6	7.6
		-8.5	-9.1	7.8	7.8	7.8	7.8	7.8	7.8
		-7.0	-7.6	8.1	8.1	8.1	8.1	8.0	8.0
		-5.0	-5.6	8.4	8.4	8.4	8.4	8.4	8.4
		-3.0	-3.7	8.8	8.8	8.7	8.7	8.7	8.7
		0.0	-0.7	9.3	9.3	9.3	9.3	9.3	8.7
		3.0	2.2	9.8	9.8	9.8	9.7	9.4	8.7
		5.0	4.1	10.2	10.1	10.0	9.7	9.4	8.7
		7.0	6.0	10.5	10.5	10.0	9.7	9.4	8.7
		9.0	7.9	10.8	10.6	10.0	9.7	9.4	8.7
		11.0	9.8	11.2	10.6	10.0	9.7	9.4	8.7
13.0	11.8	11.3	10.6	10.0	9.7	9.4	8.7		
15.0	13.7	11.3	10.6	10.0	9.7	9.4	8.7		
125	16.0	-19.8	-20.0	9.4	9.4	9.4	9.4	9.4	9.3
		-18.8	-19.0	9.7	9.7	9.7	9.7	9.6	9.6
		-16.7	-17.0	10.3	10.3	10.2	10.2	10.2	10.2
		-14.7	-15.0	10.9	10.8	10.8	10.8	10.8	10.7
		-12.6	-13.0	11.4	11.4	11.4	11.4	11.3	11.3
		-10.5	-11.0	12.0	12.0	11.9	11.9	11.9	11.9
		-9.5	-10.0	12.3	12.2	12.2	12.2	12.2	12.2
		-8.5	-9.1	12.5	12.5	12.5	12.5	12.4	12.4
		-7.0	-7.6	13.0	12.9	12.9	12.9	12.9	12.8
		-5.0	-5.6	13.5	13.5	13.5	13.4	13.4	13.4
		-3.0	-3.7	14.1	14.0	14.0	14.0	14.0	13.9
		0.0	-0.7	14.9	14.9	14.8	14.8	14.8	13.9
		3.0	2.2	15.7	15.7	15.7	15.5	15.0	13.9
		5.0	4.1	16.3	16.2	16.0	15.5	15.0	13.9
		7.0	6.0	16.8	16.8	16.0	15.5	15.0	13.9
		9.0	7.9	17.3	17.0	16.0	15.5	15.0	13.9
		11.0	9.8	17.9	17.0	16.0	15.5	15.0	13.9
13.0	11.8	18.1	17.0	16.0	15.5	15.0	13.9		
15.0	13.7	18.1	17.0	16.0	15.5	15.0	13.9		

3TW25512-2A

6 Dimensional drawing & centre of gravity

6 - 1 Dimensional drawing

FXCQ20,25,32M8

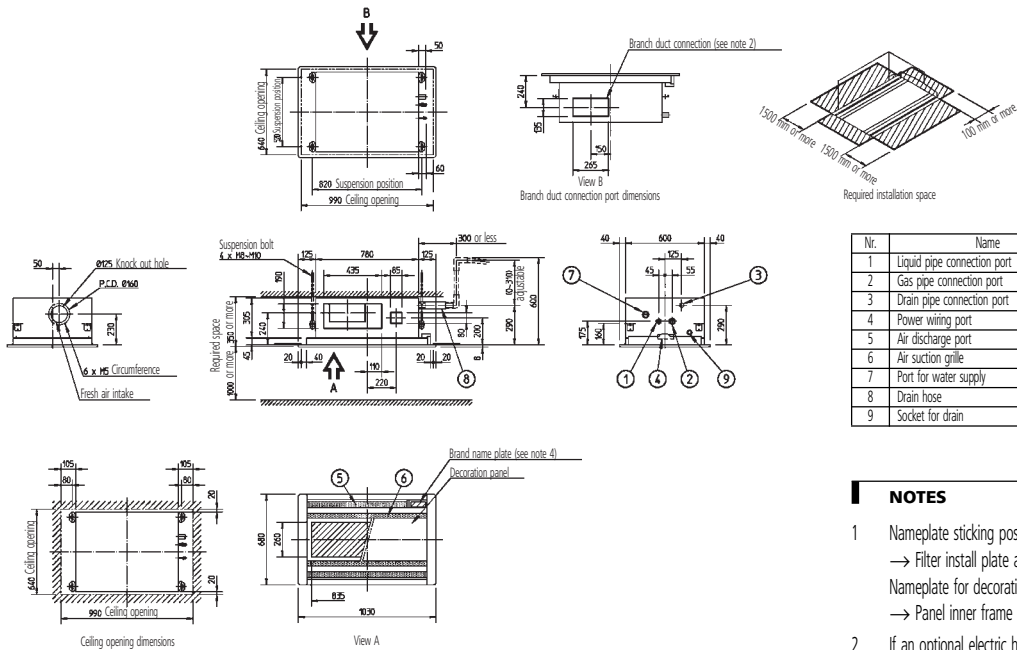

Nr.	Name	Description
1	Liquid pipe connection port	ø6.4 flare connection
2	Gas pipe connection port	ø12.7 flare connection
3	Drain pipe connection port	VP25 (O.D. ø32, I.D. ø25)
4	Power wiring port	
5	Air discharge port	
6	Air suction grille	VP25 (O.D. ø32, I.D. ø25)
7	Port for water supply	
8	Drain hose	O.D. ø32
9	Socket for drain	

NOTES

- Nameplate sticking position, Nameplate for cassette body
 → Filter install plate at the inside of the suction grille
 Nameplate for decoration panel
 → Panel inner frame at the inside of the suction grille
- If an optional electric heater is installed, a branch duct cannot be connected for safety reasons.
- When installing an optional accessory, refer to installation drawings.
- In case of using an infrared remote control, this position will be a signal receiver. Refer to the drawing of the infrared remote control for details.

3TW25514-1

FXCQ40,50M8

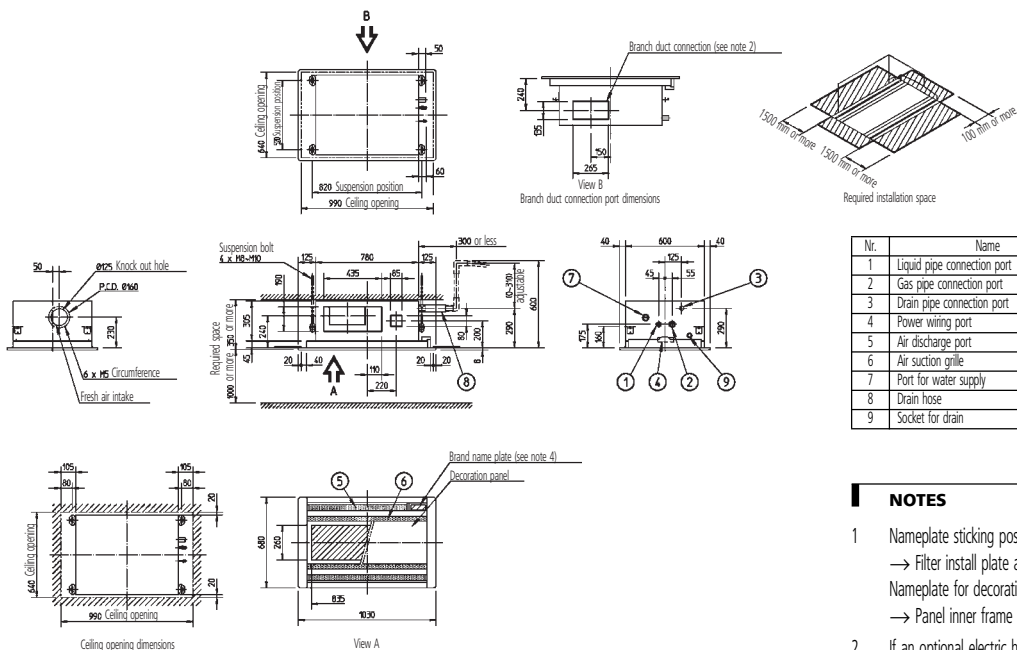

Nr.	Name	Description
1	Liquid pipe connection port	ø6.4 flare connection
2	Gas pipe connection port	ø12.7 flare connection
3	Drain pipe connection port	VP25 (O.D. ø32, I.D. ø25)
4	Power wiring port	
5	Air discharge port	
6	Air suction grille	VP25 (O.D. ø32, I.D. ø25)
7	Port for water supply	
8	Drain hose	O.D. ø32
9	Socket for drain	

NOTES

- Nameplate sticking position, Nameplate for cassette body
 → Filter install plate at the inside of the suction grille
 Nameplate for decoration panel
 → Panel inner frame at the inside of the suction grille
- If an optional electric heater is installed, a branch duct cannot be connected for safety reasons.
- When installing an optional accessory, refer to installation drawings.
- In case of using an infrared remote control, this position will be a signal receiver. Refer to the drawing of the infrared remote control for details.

3TW25544-1

6 Dimensional drawing & centre of gravity

6 - 1 Dimensional drawing

FXCQ63M8

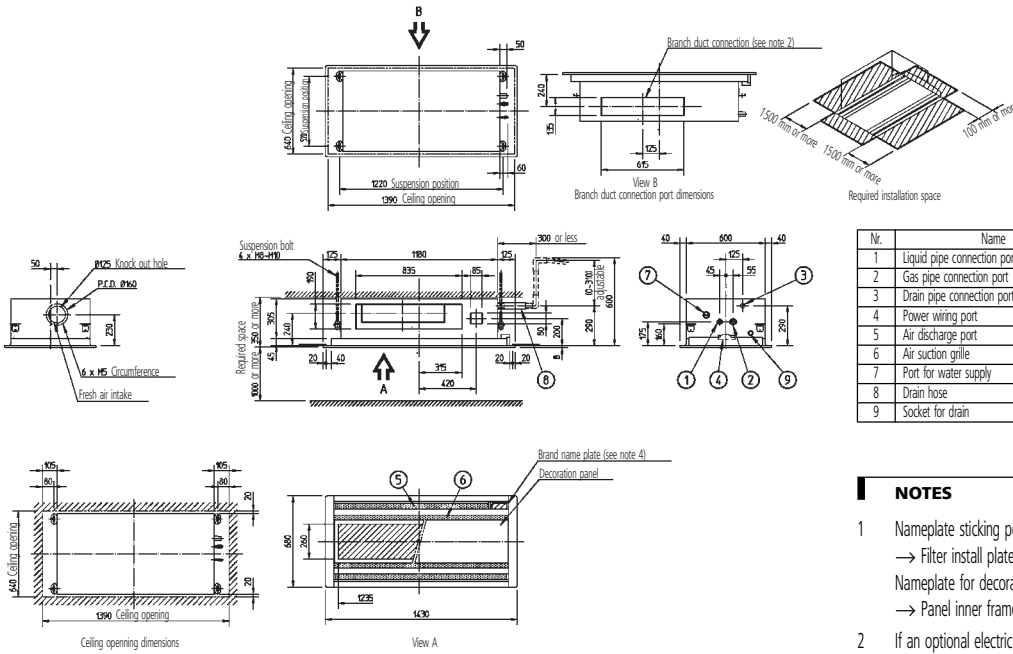

Nr.	Name	Description
1	Liquid pipe connection port	ø9.5 flare connection
2	Gas pipe connection port	ø15.9 flare connection
3	Drain pipe connection port	VP25 (O.D. ø32, I.D. ø25)
4	Power wiring port	
5	Air discharge port	
6	Air suction grille	VP25 (O.D. ø32, I.D. ø25)
7	Port for water supply	
8	Drain hose	O.D. ø32
9	Socket for drain	

NOTES

- Nameplate sticking position, Nameplate for cassette body
 → Filter install plate at the inside of the suction grille
 Nameplate for decoration panel
 → Panel inner frame at the inside of the suction grille
- If an optional electric heater is installed, a branch duct cannot be connected for safety reasons.
- When installing an optional accessory, refer to installation drawings.
- In case of using an infrared remote control, this position will be a signal receiver. Refer to the drawing of the infrared remote control for details.

3TW25564-1

FXCQ80M8

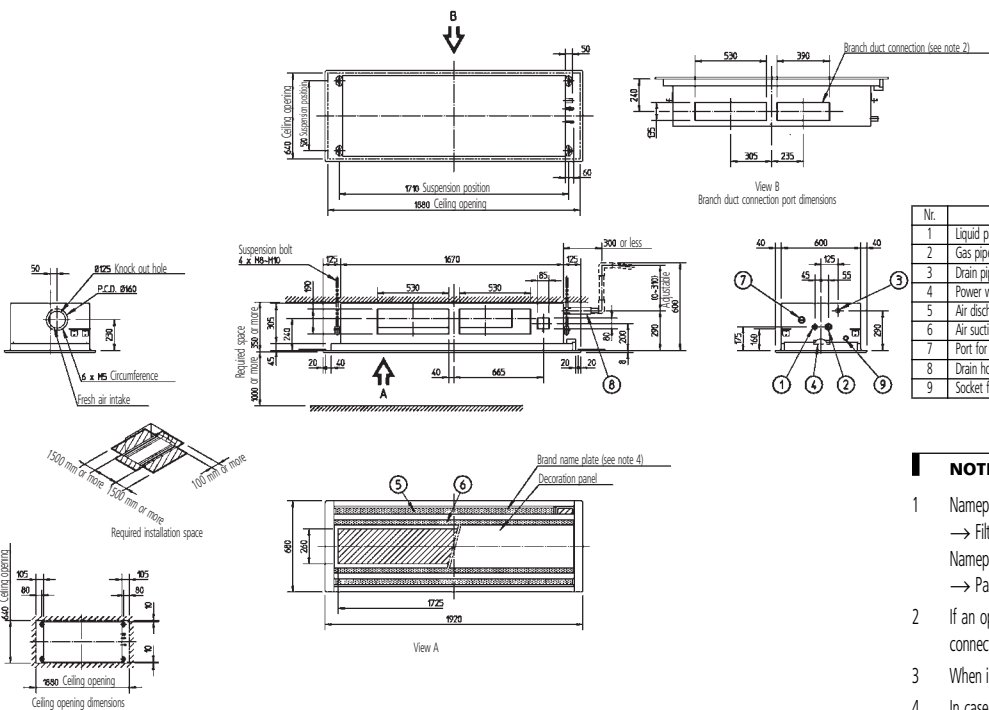

Nr.	Name	Description
1	Liquid pipe connection port	ø9.5 flare connection
2	Gas pipe connection port	ø15.9 flare connection
3	Drain pipe connection port	VP25 (O.D. ø32, I.D. ø25)
4	Power wiring port	
5	Air discharge port	
6	Air suction grille	VP25 (O.D. ø32, I.D. ø25)
7	Port for water supply	
8	Drain hose	O.D. ø32
9	Socket for drain	

NOTES

- Nameplate sticking position, Nameplate for cassette body
 → Filter install plate at the inside of the suction grille
 Nameplate for decoration panel
 → Panel inner frame at the inside of the suction grille
- If an optional electric heater is installed, a branch duct cannot be connected for safety reasons.
- When installing an optional accessory, refer to installation drawings.
- In case of using an infrared remote control, this position will be a signal receiver. Refer to the drawing of the infrared remote control for details.

3TW25574-1

6 Dimensional drawing & centre of gravity

6 - 1 Dimensional drawing

FXCQ125M8

Nr.	Name	Description
1	Liquid pipe connection port	ø9.5 flare connection
2	Gas pipe connection port	ø15.9 flare connection
3	Drain pipe connection port	VP25 (O.D. ø32, I.D. ø25)
4	Power wiring port	
5	Air discharge port	
6	Air suction grille	VP25 (O.D. ø32, I.D. ø25)
7	Port for water supply	
8	Drain hose	O.D. ø32
9	Socket for drain	

NOTES

- Nameplate sticking position, Nameplate for cassette body
 → Filter install plate at the inside of the suction grille
 Nameplate for decoration panel
 → Panel inner frame at the inside of the suction grille
- If an optional electric heater is installed, a branch duct cannot be connected for safety reasons.
- When installing an optional accessory, refer to installation drawings.
- In case of using an infrared remote control, this position will be a signal receiver. Refer to the drawing of the infrared remote control for details.

3TW25584-1

6 Dimensional drawing & centre of gravity

6 - 2 Centre of gravity

FXCQ-M8

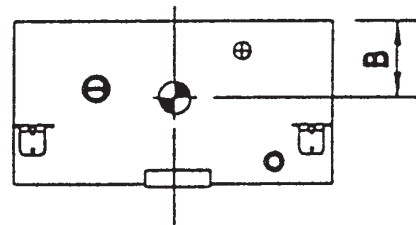
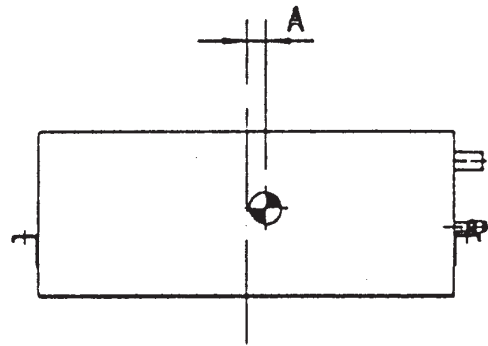
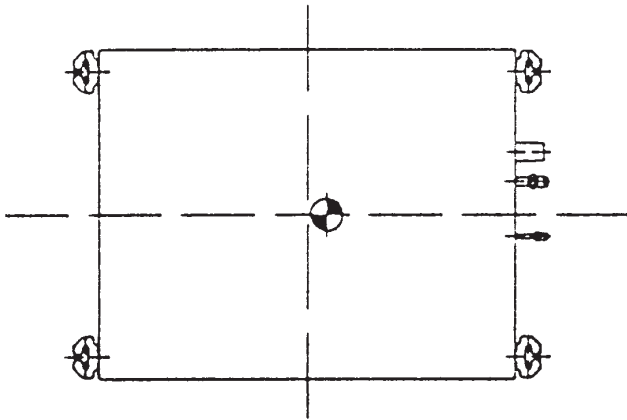

Model	A	B
FXCQ20, 25, 32M8	20	140
FXCQ40, 50M8	25	
FXCQ63M8	30	
FXCQ80, 125M8	35	

4TW25519-2

7 Piping diagram

FXCQ-M8

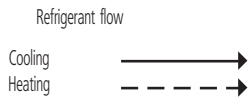
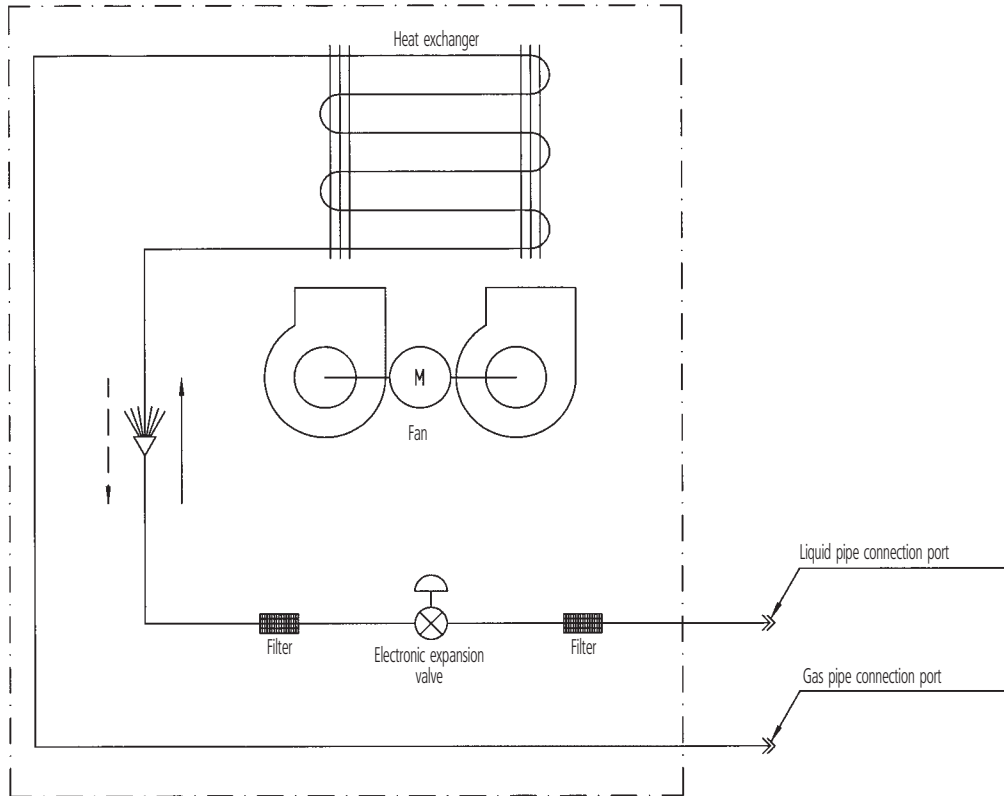

Piping connection diameter

Model	Gas	Liquid
FXCQ20,25,32,40,50M8	ø12.7	ø6.4
FXCQ63,80,125M8	ø15.9	ø9.5

3TW25515-1

8 Wiring diagram

8 - 1 Wiring diagram

FXCQ20,25,32,63M8

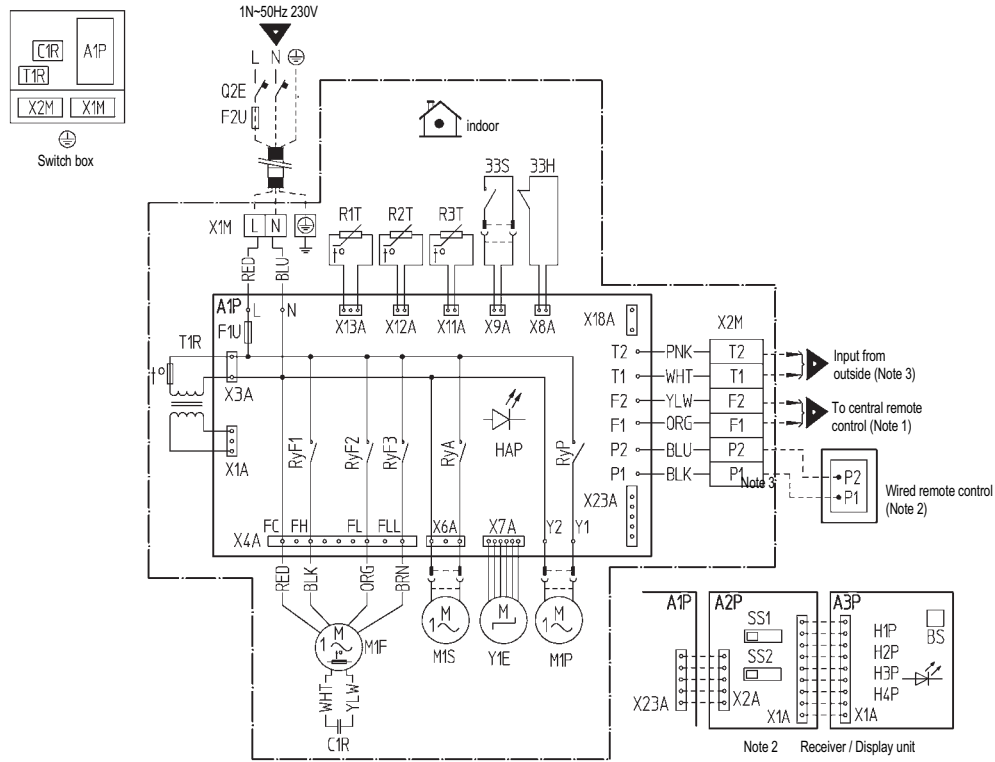

33H	Float switch	R2T,R3T	Thermistor (Coil)	BS	On/off button	
33S	Limit switch (Swing flap)	Q2E	Earth leak detector	H1P	Light emitting diode (On-red)	
A1P	Printed circuit board	RyA	Magnetic relay (M1S)	H2P	Light emitting diode (Timer-green)	
C1R	Capacitor (M1F)	RyF1-3	Magnetic relay (M1F)	H3P	Light emitting diode (filter sign-red)	
F1T	Thermal fuse (152°C) (M1F Embedded)	RyP	Magnetic relay (M1P)	H4P	Light emitting diode (defrost-orange)	
F1U	Fuse (250V)	T1R	Transformer (220-240V/22V)	SS1	Selector switch (main/sub)	
F2U	Field fuse	X1M	Terminal strip (Power)	SS2	Selector switch (wireless address set)	
HAP	Light emitting diode (service monitor-green)	X2M	Terminal strip (control)	Connector for optional parts		
M1F	Motor (Indoor fan)	Y1E	Electronic expansion valve	X18A	Connector (wiring, adapter for electrical appendices)	
M1S	Motor (Swing flap)	Receiver/Display unit (attached to infrared remote control)			X23A	Connector (infrared remote control)
M1P	Motor (Drain pump)	A2P,A3P	Printed circuit board			
R1T	Thermistor (Air)	Q2E	Earth leak detector			

- : Field wiring
- L : Live
- N : Neutral
- : Connector
- : Wire clamp
- : Protective earth (screw)

- Colors:
- BLK: Black
 - BLU: Blue
 - BRN: Brown
 - ORG: Orange
 - PNK: Pink
 - RED: Red
 - WHT: White
 - YLW: Yellow

2TW23776-1D

NOTES

- When using the central remote control, see manual for connection to the unit.
- X23A is connected when the wireless remote control kit is used.
- When connecting the input wires from the outdoor unit, "forcedoff" or "on/off" operation can be selected by the remote control, for more details see installation manual.
- Use copper conductors only.

8 Wiring diagram

8 - 1 Wiring diagram

FXCQ40,50,80,125M8

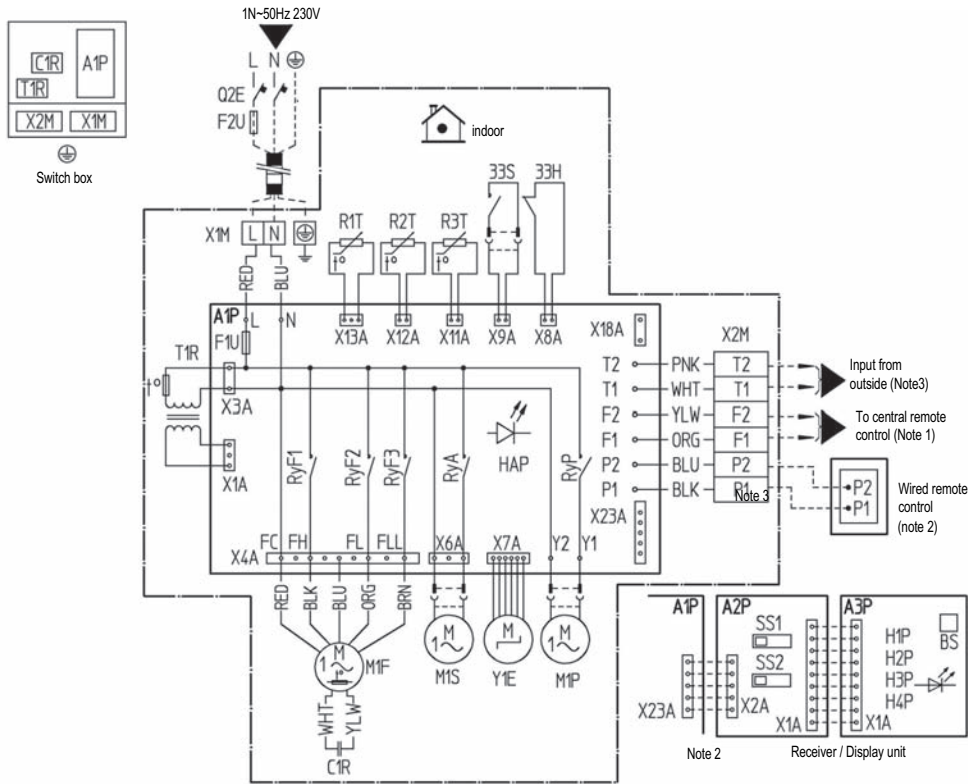

33H	Float switch	R2T, R3T	thermistor (coil)	BS	On/off button
33S	Limit switch (Swing flap)	Q2E	Earth leak detector	H1P	Light emitting diode (on-red)
A1P	Printed circuit board	RyA	Magnetic relay (M1S)	H2P	Light emitting diode (timer-green)
C1R	Capacitor (M1F)	RyF1-3	Magnetic relay (M1F)	H3P	Light emitting diode (filter sign-red)
F1T	Thermal fuse (152°C)(M1F embedded)	RyP	Magnetic relay (M1P)	H4P	Light emitting diode (defrost-orange)
F1U	Fuse (250V, 5A)	T1R	Transformer (220-240V/22V)	SS1	Selector switch (main/sub)
F2U	Field fuse	X1M	Terminal strip (power)	SS2	Selector switch (Wireless address set)
HAP	Light emitting diode (service monitor green)	X2M	Terminal strip (control)	Connector for optional parts	
M1F	Motor (Indoor fan)	Y1E	Electronic expansion valve	X18A	Connector (wiring, adaptor for electrical appendices)
M1S	Motor (Swing flap)	Receiver/display unit (attached to wireless remote control)		X23A	Connector (wireless remote control)
M1P	Motor (drain pump)				
R1T	Thermistor (air)	A2P, A3P	printed circuit board		

- : Field wiring
 - L : Live
 - N : Neutral
 - : Connector
 - : Wire clamp
 - : Protective earth (screw)
- Colors: BLK: Black PNK: Pink
 BLU: Blue RED: Red
 BRN: Brown WHT: White
 ORG: Orange YLW: Yellow

2TW23806-1D

NOTES

- When using the central remote control, see manual for connection to the unit.
- X23A is connected when the wireless remote control kit is used.
- When the connecting the input wires from the outdoor unit, "forced off" or "on/off operation can be selected by the remote control for more details see installation manual.
- Use copper conductors only.

9 Sound data

9 - 1 Sound level data

FXCQ-M8

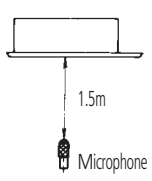
Model	Sound pressure level - 230V		Measuring location	Sound power level
	H	L		
FXCQ20M8	33	28		45
FXCQ25M8	35	29		50
FXCQ32M8	35	29		50
FXCQ40M8	35.5	30.5		50
FXCQ50M8	35.5	30.5		50
FXCQ63M8	38	33		52
FXCQ80M8	40	35		54
FXCQ125M8	45	39		60

NOTES

- 1 dBA = A-weighted sound pressure level (A-scale according to IEC).
- 2 Reference acoustic pressure 0 dB = 20 Pa.
- 3 These operating values were obtained in a dead room (conversion values). Noise values will vary depending on a range of factors such as the construction of the particular room in which the equipment is installed.
- 4 Operating noise differs with operation and ambient conditions.

9 Sound data

9 - 2 Sound pressure spectrum

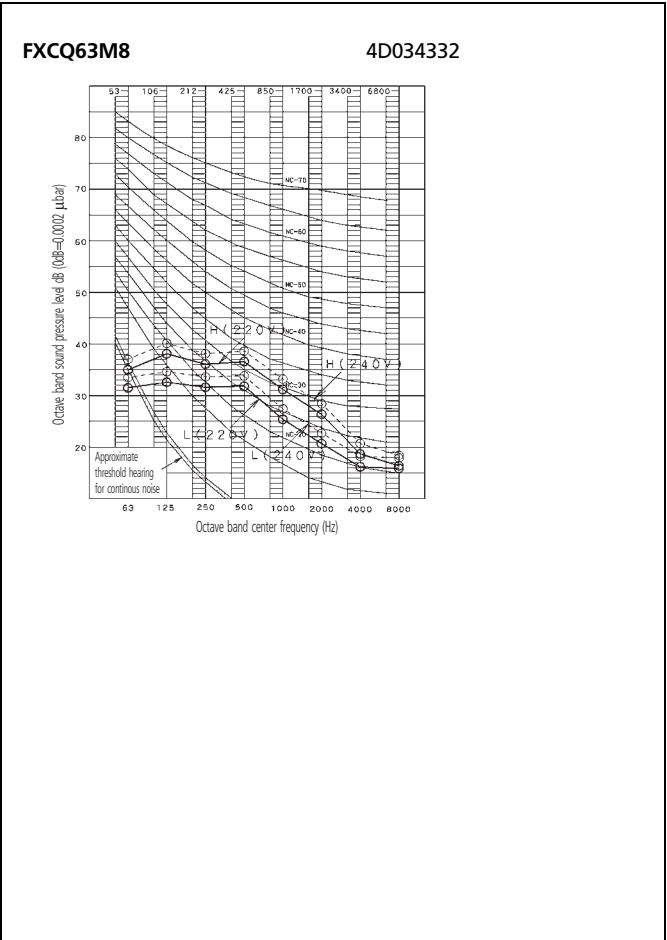
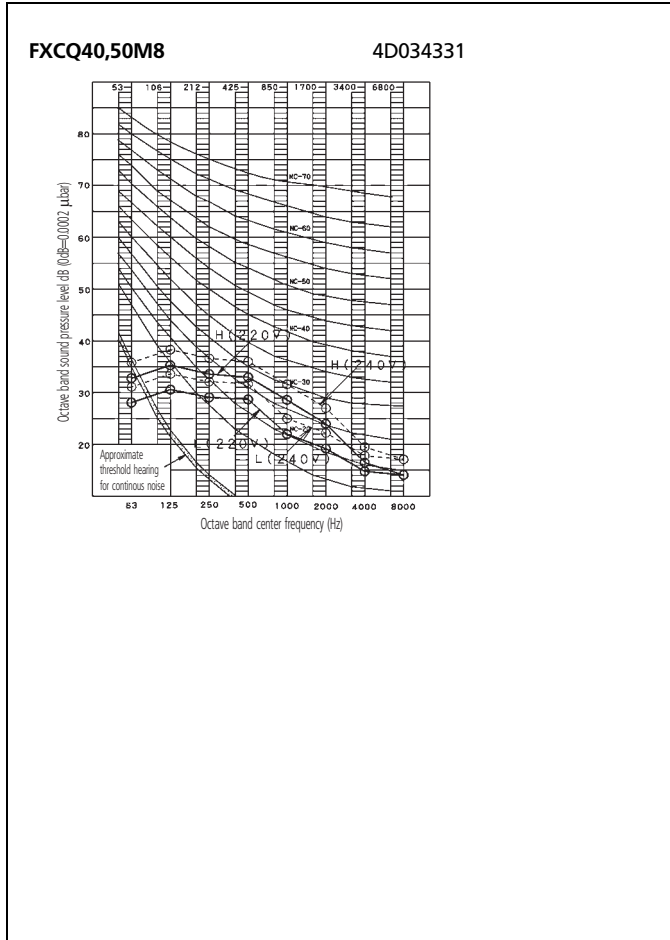
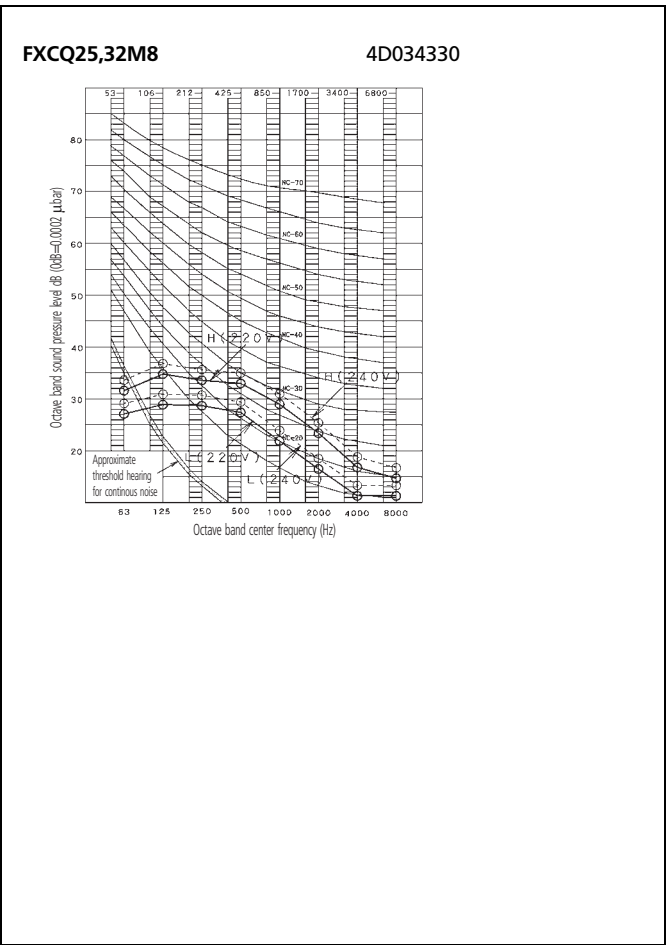
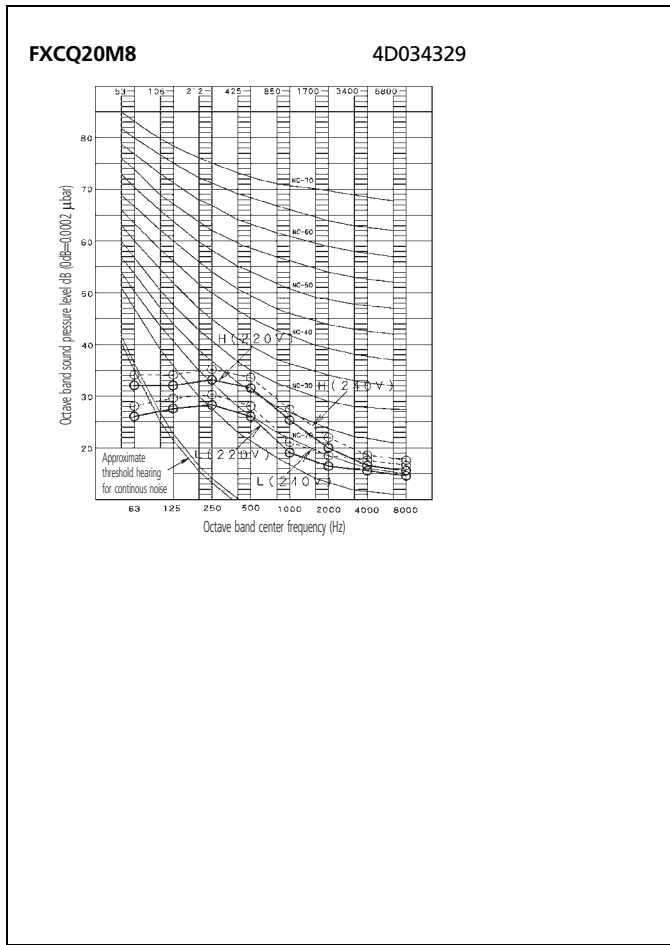

9 Sound data

9 - 2 Sound pressure spectrum

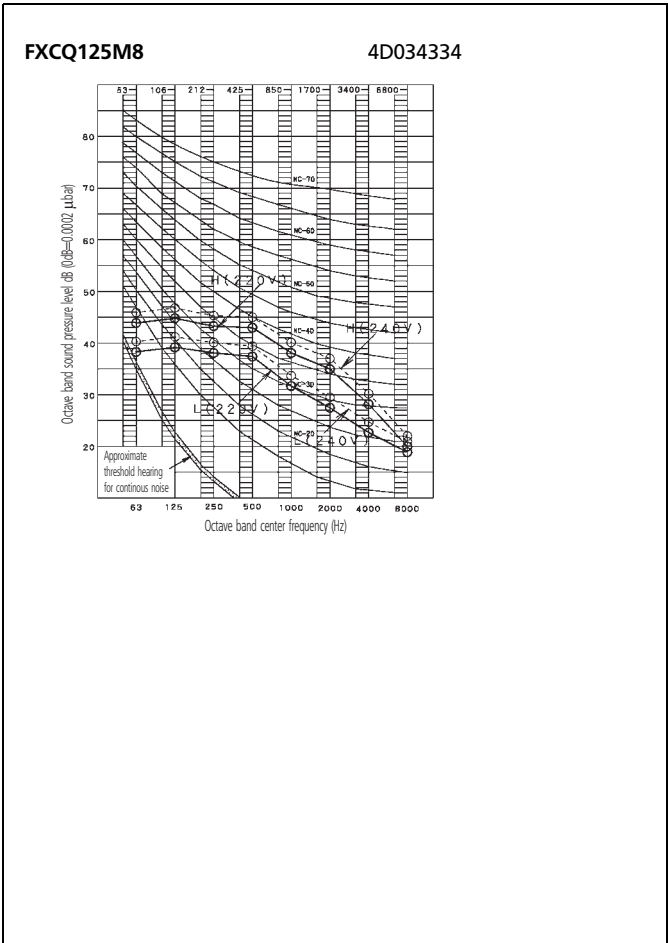
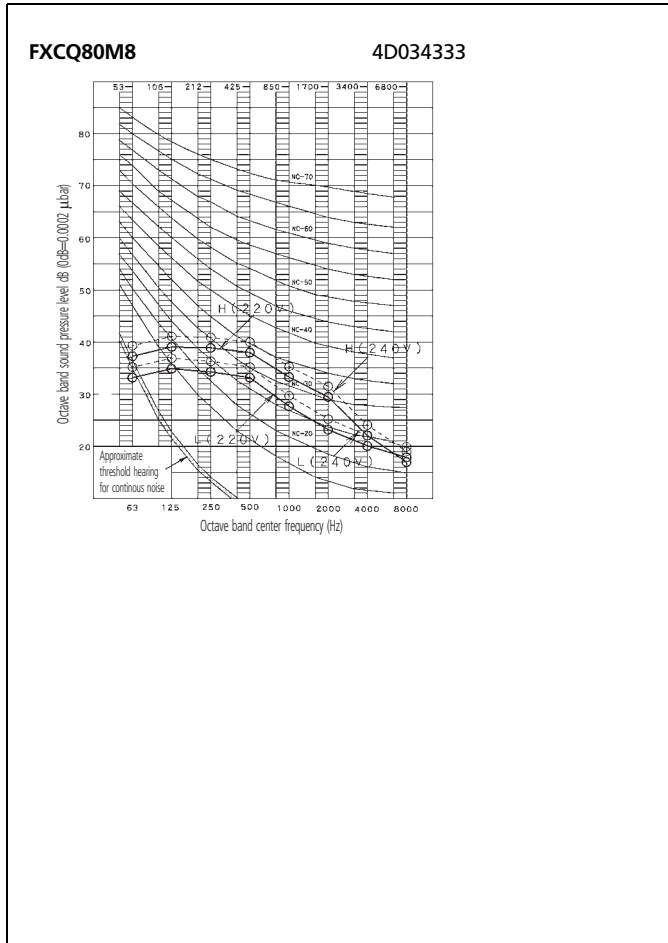

10 Air flow pattern

FXCQ63M8

Heating air velocity distribution

Discharge angle: 60°

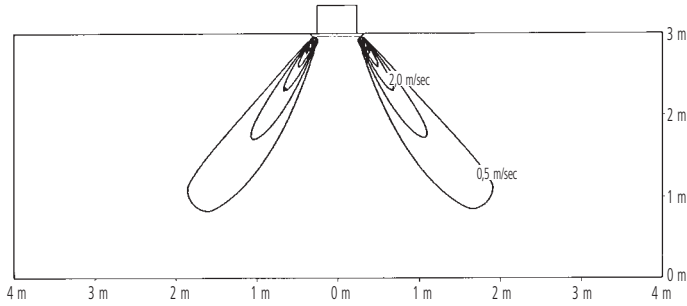

Heating temperature distribution

Discharge angle: 60°

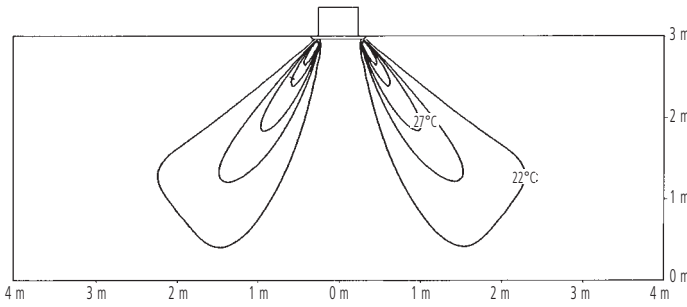

NOTES

- 1 The standard set-up height of the 2-way blow type is 3 m maximum. Shown here is the measurement distribution at a ceiling height of 3 m.

FXCQ125M8

Heating air velocity distribution

Discharge angle: 60°

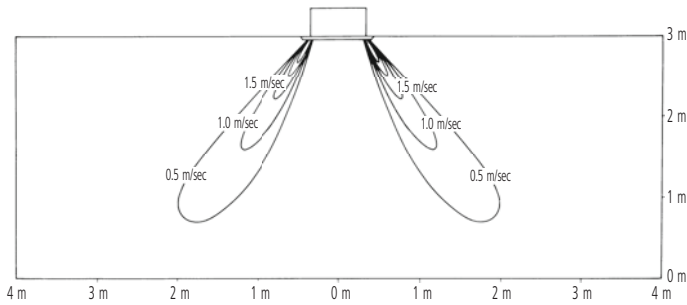

Heating temperature distribution

Discharge angle: 60°

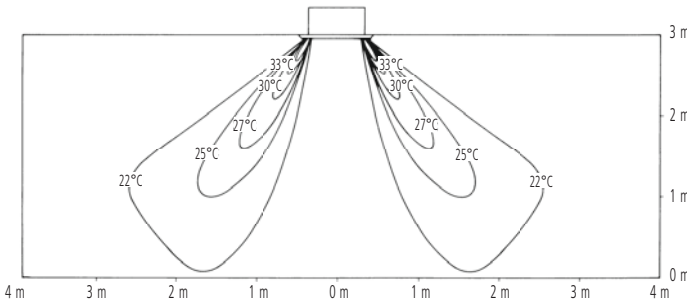

NOTES

- 1 The standard set-up height of the 2-way blow type is 3 m maximum. Shown here is the measurement distribution at a ceiling height of 3 m.



Daikin's unique position as a manufacturer of air conditioning equipment, compressors and refrigerants has led to its close involvement in environmental issues. For several years Daikin has had the intention to become a leader in the provision of products that have limited impact on the environment. This challenge demands the eco design and development of a wide range of products and an energy management system, resulting in energy conservation and a reduction of waste.

VRV[®] products are not within the scope of the Eurovent certification programme.



The present publication is drawn up by way of information only and does not constitute an offer binding upon Daikin Europe N.V. Daikin Europe N.V. has compiled the content of this publication to the best of its knowledge. No express or implied warranty is given for the completeness, accuracy, reliability or fitness for particular purpose of its content and the products and services presented therein. Specifications are subject to change without prior notice. Daikin Europe N.V. explicitly rejects any liability for any direct or indirect damage, in the broadest sense, arising from or related to the use and/or interpretation of this publication. All content is copyrighted by Daikin Europe N.V.

Daikin products are distributed by: