***VRV* SYSTEM Inverter Air Conditioners**

MODELS

Ceiling Suspended type

FXH32LVE
FXH63LVE
FXH100LVE

FXHQ32MVE
FXHQ63MVE
FXHQ100MVE

FXHQ32MAVE
FXHQ63MAVE
FXHQ100MAVE

English

Deutsch

Français

Español

Italiano

Ελληνικά

Nederlands

Portugues

Русский

中文
(繁體)中文
(简体)

Thank you for purchasing this Daikin air conditioner. Carefully read this operation manual before using the air conditioner. It will tell you how to use the unit properly and help you if any trouble occurs. This manual explains about the indoor unit only. Use it along with the operation manual for the outdoor unit. After reading the manual, file it away for future reference.

Vielen Dank für den Kauf einer Klimaanlage von Daikin. Lesen Sie dieses Betriebshandbuch vor Inbetriebnahme der Klimaanlage sorgfältig durch. Sie erfahren hier, wie die Einheit korrekt genutzt wird, und es ist Ihnen bei Störungen behilflich. Das Betriebsbuch erklärt nur das Innenaggregat. Verwenden Sie es deshalb zusammen mit dem entsprechenden Handbuch für das Aussenaggregat. Wenn Sie das Handbuch durchgelesen haben, bewahren Sie es gut auf, damit Sie auch später noch nachschlagen können.

Nous vous remercions pour votre acquisition de ce système de climatisation Daikin. Lisez attentivement ce manuel avant d'utiliser le climatiseur. Il vous expliquera comment vous servir correctement de l'appareil et vous guidera en cas de problème. Ce manuel ne décrit que l'unité intérieure. Utilisez-le avec le manuel de l'unité extérieure. Lorsqu'on vous aura lu le manuel, rangez-le afin de pouvoir vous y référer ultérieurement.

Le agradecemos la compra de este acondicionador de aire Daikin. Lea cuidadosamente el manual de funcionamiento antes de utilizar el acondicionador de aire. Dicho manual le indicará cómo utilizar adecuadamente la máquina y le ayudará en caso de avería. Este manual describe sólo la unidad interior. Utilice conjuntamente con el manual de instrucciones de la unidad exterior. Después de leer el manual, consérvelo para consultas futuras.

La ringraziamo di aver acquistato questo condizionatore d'aria Daikin. Leggere attentamente questo manuale prima di utilizzare il condizionatore. Contiene le istruzioni per usare correttamente l'unità e per rimediare ad eventuali problemi di funzionamento. Il presente manuale è valido per l'unità interna. Utilizzarlo congiuntamente al manuale d'istruzioni per l'unità esterna. Dopo averlo letto, conservare il manuale per consultazioni future.

Σας ευχαριστούμε που αγοράσατε αυτή την κλιματιστική συσκευή της Daikin. Διαβάστε προσεκτικά αυτό το εγχειρίδιο χρήσης πριν χρησιμοποιήσετε την κλιματιστική συσκευή. Θα σας εξηγήσει πώς να χρησιμοποιείτε τη μονάδα σωστά και θα σας βοηθήσει αν παρουσιαστεί κάποιο πρόβλημα. Αυτό το εγχειρίδιο περιγράφει μόνο την εσωτερική μονάδα. Χρησιμοποιήστε το μαζί με το εγχειρίδιο λειτουργίας για την εξωτερική μονάδα. Αφού διαβάσετε το εγχειρίδιο, φυλάξτε το για μελλοντική χρήση.

Wij danken u voor de aankoop van deze Daikin-airconditioner.

Lees deze bedrijfshandleiding aandachtig door voordat u de airconditioner gebruikt. Het omvat uitleg over het correcte gebruik van de unit en biedt hulp in geval een storing mocht optreden. Deze handleiding beschrijft alleen het binnentoestel. Gebruik ze samen met de bedieningshandleiding voor het buitentoestel. Gebruik deze handleiding voor verdere raadpleging.

Obrigado pela sua compra deste aparelho de ar condicionado Daikin.

Leia com atenção este manual de operação antes de proceder à utilização do aparelho de ar condicionado. Este indicar-lhe-á como deverá utilizar a unidade correctamente e ajudá-lo-á no caso de surgir qualquer problema. Este manual apenas contém explicações sobre a unidade interior. Use-o em conjunto com o manual de operação da unidade exterior. Depois de ler o manual, guarde-o a fim de o poder consultar caso venha a ser preciso.

Благодарим за покупку кондиционера Daikin. До начала работы с кондиционером внимательно изучите данное руководство по эксплуатации. В нем излагаются правила пользования и приводятся рекомендации по поиску и устранению неисправностей. В данном руководстве рассматривается только комнатный блок. Используйте его вместе с руководством для наружного блока. После изучения руководства сохраните его для справки.

感謝您購買大金的空調機。在使用本空調機之前，請仔細閱讀本使用說明書。本說明書說明空調機的正确的使用方法，以及發生故障時的對應措施。本使用說明書為室內機專用的說明書，請同時參照閱讀室外機附帶的使用說明書。閱讀完畢本說明書以後，請妥善保管，以備需要時查閱。

感谢您购买大金的空调机。在使用本空调机之前，请仔细阅读本使用说明书。本说明书说明空调机的正确使用方法，以及发生故障时的对应措施。本使用说明书为室内机专用的说明书，请同时参照阅读室外机附带的说明书。阅读完毕本说明书以后，请妥善保管，以备需要时查阅。

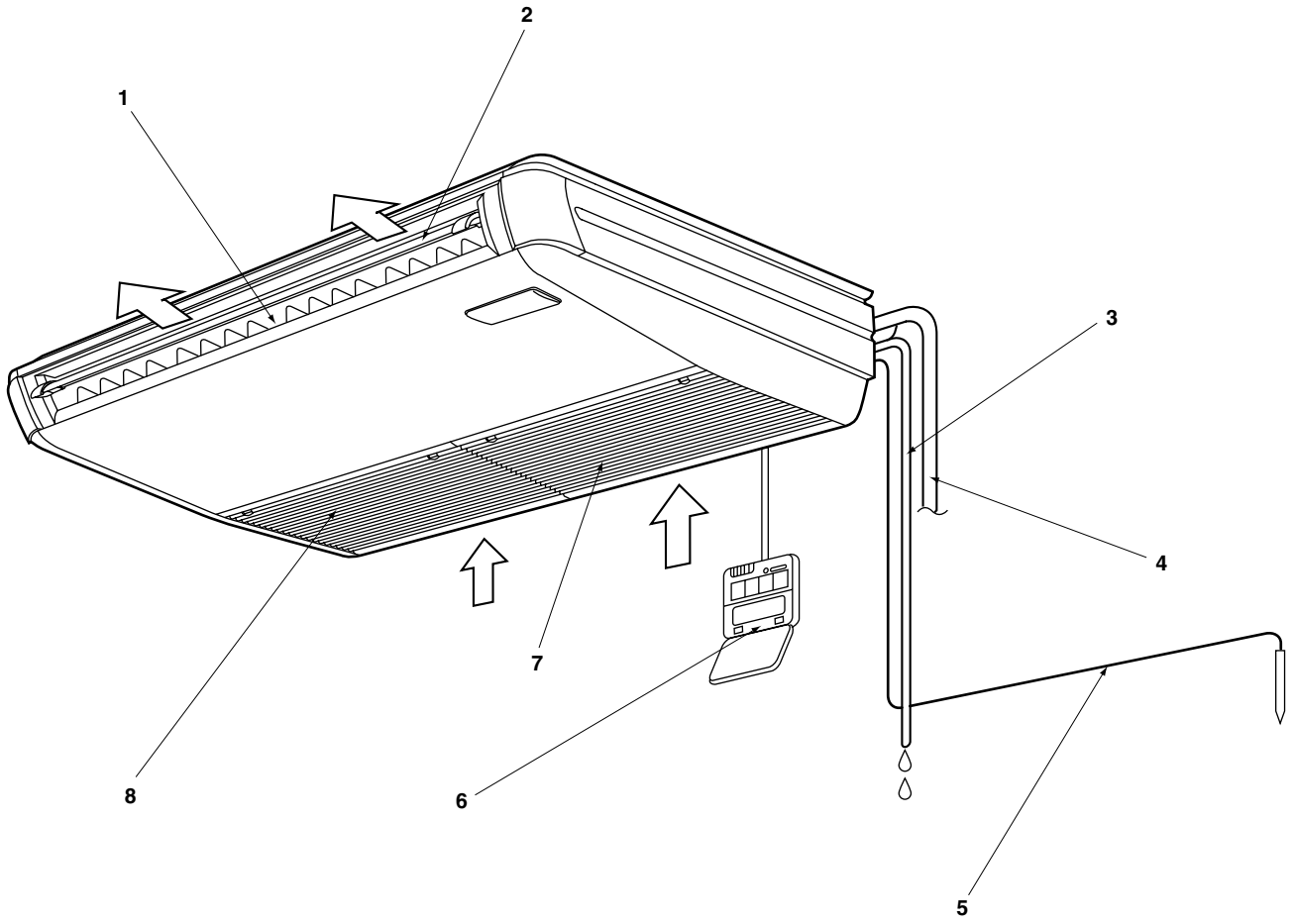

1

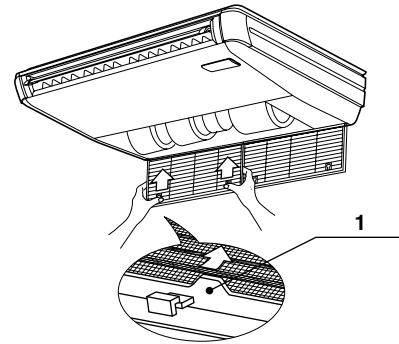
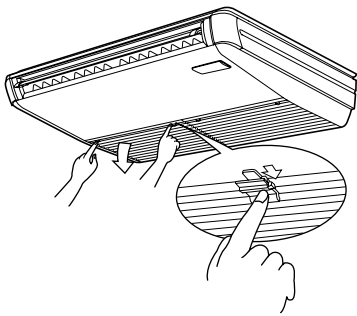

2

3

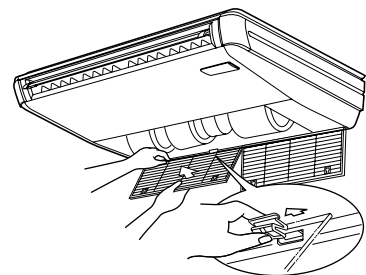
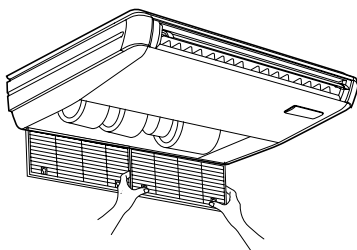

4

5

Important information regarding the refrigerant used

This product contains fluorinated greenhouse gases covered by the Kyoto Protocol.

Refrigerant type	R410A	R407C
GWP ⁽¹⁾ value	1975	1652.5

⁽¹⁾ GWP = global warming potential

Periodical inspections for refrigerant leaks may be required depending on European or local legislation. Please contact your local dealer for more information.

SAFETY CONSIDERATIONS

Be sure to follow them.

(Before operation, read this operation manual carefully to operate it properly.)

- This air conditioner comes under the term “appliances not accessible to the general public”.
- **Cautions indicated here are classified into the following two types.**
Each type of caution describes important contents relate to safety. Make sure to observe each caution.

⚠ WARNING..... These are the matters with possibilities leading to serious consequences such as death or serious injury due to erroneous handling.

⚠ CAUTION..... These are the matters with possibilities leading to injury or material damage due to erroneous handling including probabilities leading to serious consequences in some cases.

⚠ CAUTION.....

- **Do not place objects in direct proximity of the outdoor unit and do not let leaves and other debris accumulate around the unit.**

Leaves are a hotbed for small animals which can enter the unit. Once in the unit, such animals can cause malfunctions, smoke or fire when making contact with electrical parts.

NAME OF PARTS

Refer to figure 1 on page [1]

1. Air outlet
2. Air flow flap (at air outlet)
3. Drain pipe
4. Refrigerant pipe
Transmission wiring
5. Grounding wire
Conducts electricity from the unit into the ground to prevent electric shock.
6. Remote controller
7. Suction grille
8. Air filter (inside suction grille)

MAINTENANCE (FOR SERVICE PERSONNEL)

⚠ WARNING.....

- **Only a qualified person is allowed to perform maintenance without daily maintenance.**
- **Before touching any of connection wirings, be sure to turn off all power supply switches.**
- **For installation of optional parts, only a qualified person is allowed to do so.**

Be sure to use optional parts specified by our company. Installation in your own manner may result in water leakage, electric shock or fire.

⚠ CAUTION.....

- **Be sure to stop operation and turn the power switch off before cleaning the air conditioner.**
Otherwise, an electric shock or injury may result.
- **Do not wash the air conditioner with water.**
Doing so may result in an electric shock.
- **Consult with installation contractor for cleaning the inside of the air conditioner.**
Wrong cleaning may make the plastics parts broken or cause failure of water leakage or electric shock.
- **Watch your steps at the time of air filter cleaning or inspection.**
High-place work is required, to which utmost attention must be paid.
If the scaffold is unstable, you may fall or topple down, thus causing injury.

HOW TO CLEAN THE AIR FILTER

Clean the air filter when the display shows “” (TIME TO CLEAN AIR FILTER).

Increase the frequency of cleaning if the unit is installed in a room where the air is extremely contaminated.

(As a yardstick for regulating yourself, consider cleaning the filter once a half year.)

If the dirt becomes impossible to clean, change the air filter. (Air filter for exchange is optional.)

1. Open the suction grille.

Slide both knobs simultaneously as shown and then pull them downward.

(Do the same procedure for closing.)

Refer to figure 2 on page [1]

2. Remove the air filters.

Pull the two tabs up and remove.

Refer to figure 3 on page [1]

1. Tab

3. Clean the air filter.

Use vacuum cleaner **A)** or wash the air filter with water **B).**

A) Using a vacuum cleaner



- B) Washing with water**
To clean the air filter, use soft brush and neutral detergent.



Remove water and dry in the shade.

NOTE 

- Do not wash the air conditioner with hot water of more than 50°C. Doing so may result in discoloration or deformation.
- Never dry the filter by direct firing. Doing so may result in burning.

4. Fix the air filter.

- Return the air filter to its original place once cleaning is completed.

Refer to figure 4 on page [1]

5. Shut the air inlet grille.

Refer to item No. 1.

6. Press the FILTER SIGN RESET BUTTON on the remote controller.

The display “” (TIME TO CLEAN AIR FILTER) vanishes.

(For details, see the operation manual for the outdoor unit.)

NOTE 

- Do not remove the air filter except when cleaning. Unnecessary handling may damage the filter.

HOW TO CLEAN AIR OUTLET AND OUTSIDE PANELS

- Clean with soft cloth.
- When it is difficult to remove stains, use water or neutral detergent.

NOTE 

- Do not use gasoline, benzene, thinner, polishing powder, liquid insecticide. It may cause discoloring or warping.
- Do not let the indoor unit get wet. It may cause an electric shock or a fire.
- Do not use hot water of 50°C or higher, as doing so may result in discoloration or deformation.

HOW TO CLEAN THE SUCTION GRILLE

1. Open the suction grille.

Slide both knobs and then pull them downward.
(Do the same procedure for closing.)

Refer to figure 2 on page [1]

2. Detach the air filter.

Refer to “HOW TO CLEAN THE AIR FILTER”.

3. Detach the suction grille.

With the intake grille open, hold the rear tabs and pull the intake grille forward.

Refer to figure 5 on page [1]

4. Clean the suction grille.

Wash with a soft bristle brush and neutral detergent or water, and dry thoroughly.



NOTE 

- When badly soiled, spray with a typical kitchen cleanser and let sit for about 10 minutes. Then, wash with water.
- Do not use hot water of 50°C or higher, as doing so may result in discoloration or deformation.

5. Reattach the suction grille.

Refer to item No. 3.

6. Reattach the air filter.

Refer to “HOW TO CLEAN THE AIR FILTER”.

7. Close the suction grille.

Refer to item No. 1.

DAIKIN INDUSTRIES, LTD.

Head office:

Umeda Center Bldg., 2-4-12, Nakazaki-Nishi,
Kita-ku, Osaka, 530-8323 Japan

Tokyo office:

JR Shinagawa East Bldg., 2-18-1, Konan,
Minato-ku, Tokyo, 108-0075 Japan

大金工業株式会社

總公司

日本大阪府大阪市北區中崎西二丁目4番12號
梅田中心大廈 郵政編號 530-8323

東京分公司

日本東京都港區港南二丁目18番1號
JR品川東大廈 郵政編碼108-0075

DAIKIN EUROPE NV

Zandvoordestraat 300, B-8400 Oostende, Belgium

大金工業株式会社

总公司

日本大阪府大阪市北区中崎西二丁目4番12号
梅田中心大廈 邮政编码 530-8323

东京分公司

日本東京都港區港南二丁目18番1号
JR品川東大廈 邮政编码108-0075