



Air Conditioners

Technical Data

VRV[®] III-S

VRV[®] Heat Pump



EEDEN10-200

RXYSQ4-6PAV

TABLE OF CONTENTS

RXYSQ4-6PAV

1	Specifications	478
	Technical Specifications	478
	Electrical Specifications (50Hz)	480
2	Options	481
3	Capacity tables	482
	Cooling capacity tables	482
	Heating capacity tables	488
4	Dimensional drawing & centre of gravity	494
	Dimensional drawing	494
	Centre of gravity	495
5	Piping diagram.....	496
6	Wiring diagram.....	497
	Wiring diagram	497
	External connection diagram	498
7	Sound data.....	499
	Sound pressure spectrum	499
	Sound power spectrum	501
8	Installation.....	502
	Service space	502
9	Operation range	504

1 Specifications

1-1 Technical Specifications				RXYSQ4PA7V1B	RXYSQ5PA7V1B	RXYSQ6PA7V1B	
Capacity	Cooling	kW		11.2	14.0	15.5	
	Heating	kW		12.5	16.0	18.0	
COP	Cooling			3.99	3.99	3.42	
	Heating			4.56	4.15	3.94	
Capacity range		HP		4	5	6	
PED category	Category I						
Max no of indoor units to be connected				6	8	9	
Indoor index connection	Minimum			50	62.5	70	
	Maximum			130	162.5	182	
Casing	Colour	Daikin White					
	Material	Painted galvanised steel					
Dimensions	Packing	Height	mm	1,524			
		Width	mm	980	980	980	
		Depth	mm	420	420	420	
	Unit	Height	mm	1,345			
		Width	mm	900	900	900	
		Depth	mm	320	320	320	
Weight	Unit	kg		120	120	120	
	Packed Unit	kg		130	130	130	
Packing	Material	Carton, wood + EPS					
	Weight	kg		8	8	8	
Heat Exchanger	Dimensions	Length	mm	857	857	857	
		Nr of Rows		2	2	2	
		Fin Pitch	mm	2	2	2	
		Nr of Passes		10	10	10	
		Face Area	m ²	1,131			
		Nr of Stages		60	60	60	
	Tube type	Hi-XSS (8)					
	Fin	Fin type	Non-symmetric waffle louvre				
Treatment		Corrosion resistant					
Fan	Type	Propeller					
	Quantity			2	2	2	
Air Flow Rate (nominal at 230V)	Cooling	m ³ /min		106	106	106	
	Heating	m ³ /min		102	105	105	
Fan	Discharge direction	Horizontal					
	Motor	Quantity		2	2	2	
		Model	Brushless DC motor				
Motor	Speed (nominal)	Cooling	rpm	850/815			
		Heating	rpm	820/785	840/805	840/805	
Fan	Motor	Drive	Direct drive				
		Output motor	W	70	70	70	
Compressor	Quantity			1	1	1	
	Motor	Quantity		1	1	1	
		Model	JT100G-VDL				
		Type	Hermetically sealed scroll compressor				
		Speed	rpm	6,480			
		Motor Output	kW	2.5	3.0	3.5	
		Starting Method	Direct on line				
		Crankcase Heater	W	33	33	33	
Cooling	Standard	Min	°CDB	-5	-5	-5	
Operation Range	Cooling	Max	°CDB	46	46	46	
		Heating	Min	°CWB	-20	-20	-20
	Heating	Max	°CWB	15.5	15.5	15.5	

1 Specifications

1-1 Technical Specifications				RXYSQ4PA7V1B	RXYSQ5PA7V1B	RXYSQ6PA7V1B
Sound level	Cooling	Sound Power (Nominal)	dBA	66	67	69
		Sound Pressure (Nominal)	dBA	50	51	53
	Heating	Sound Pressure (Nominal)	dBA	52	53	55
Refrigerant	Name			R-410A		
	Charge		kg	4.0	4.0	4.0
	Control			Expansion valve (electronic type)		
	Nr of Circuits			1	1	1
Refrigerant Oil	Name			Daphne FVC68D		
	Charged Volume		l	1.5	1.5	1.5
Piping connections	Liquid (OD)	Type		Flare connection		
		Diameter (OD)	mm	9.52	9.52	9.52
	Gas	Type		Flare connection	Flare connection	Braze connection
		Diameter (OD)	mm	15.9	15.9	19.1
	Drain	Quantity		3	3	3
		Diameter (OD)	mm	26 x 3		
	Heat Insulation			Both liquid and gas pipes		
Max total length		m	300	300	300	
Defrost Method				Reversed cycle		
Defrost Control				Sensor for outdoor heat exchanger temperature		
Capacity Control Method				Inverter controlled		
Capacity Control				24 to 100		
Safety devices				HPS		
				Fan motor thermal protection		
				Inverter overload protector		
				PC board fuse		
Standard Accessories	Standard Accessories			Installation manual		
	Quantity			1	1	1
	Standard Accessories			Operation manual		
	Quantity			1	1	1
	Standard Accessories					Connection pipes
Quantity					3	
Notes				Nominal cooling capacities are based on : indoor temperature : 27°CDB, 19°CWB, outdoor temperature : 35°CDB, equivalent refrigerant piping : 5m, level difference : 0m.		
				Nominal heating capacities are based on : indoor temperature : 20°CDB, outdoor temperature : 7°CDB, 6°CWB, equivalent refrigerant piping : 5m, level difference : 0m		
				Sound pressure level is a relative value, depending on the distance and acoustic environment. For more details, please refer to sound level drawings.		
				Sound power level is an absolute value that a sound source generates.		
				Sound values are measured in a semi-anechoic room.		

1 Specifications

1-2 Electrical Specifications (50Hz)				RXYSQ4PA7V1B	RXYSQ5PA7V1B	RXYSQ6PA7V1B
Power Supply	Name			V1		
	Phase			1N~		
	Frequency	Hz		50		
	Voltage			220-240		
Current	Nominal running current (RLA)	Cooling	A	15.9	20.2	22.2
	Starting current (MSC)			15.9	20.2	22.2
	Minimum Ssc value			kVa		
	Maximum Running Current			27.0	27.0	27.0
	Minimum circuit amps (MCA)			27.0	27.0	27.0
	Maximum fuse amps (MFA)			32.0	32.0	32.0
	Full load amps (FLA)			0.3+0.3 (Fan motor)		
Voltage range	Minimum			198	198	198
	Maximum			264	264	264
Wiring connections	For Power Supply	Quantity		3	3	3
		Remark	Earth wire included			
	For connection with indoor	Quantity		2	2	2
		Remark	F1+F2			
Power Supply Intake				Both indoor and outdoor unit		
Field earth leakage breaker			mA	300	300	300
Notes				RLA is based on following conditions : indoor temperature : 27°CDB/19°CWB , outdoor temperature : 35°CDB		
				Voltage range : units are suitable for use on electrical systems where voltage supplied to unit terminal is not below or above listed range limits		
				Maximum allowable voltage range variation between phases is 2%		
				Instead of fuse, use circuit breaker. MFA is used to select circuit breaker and the ground fault circuit interrupter (earth leakage circuit breaker)		
				MSC means the maximum current during start up of the compressor		
				Select wire size based on MCA		
				EN/IEC 61000-3-12: European/international technical standard setting the limits for harmonic currents produced by equipment connected to public low-voltage system with input current > 16A and <= 75A per phase		
SSC means: Short-circuit power						

2 Options

RXYSQ-PV

No	Item	RXYSQ4PV	RXYSQ5PV	RXYSQ6PV
1	COOL/HEAT SELECTOR		KRC19-26A6	
2	FIXING BOX		KJB111A	
3	REFNET HEADER		KHRQ22M29H	
4	REFNET JOINT		KHRQ22M20T	
5	CENTRAL DRAIN PAN KIT		KKPJ5F180	

NOTES

- 1 All options are kits.

4TW26101-4A

3 Capacity tables

3 - 1 Cooling capacity tables

RXYSQ4PAV1			TC: Total capacity (kW); PI: Power Input (kW) (Compressor + Outdoor fan motor)															
Combination (%)	Capacity index (kW)	Outdoor air temp.(°CDB)	Indoor air temp. (°CWB)															
			14.0		16.0		18.0		19.0		20.0		22.0		24.0			
			TC kW	PI kW	TC kW	PI kW	TC kW	PI kW	TC kW	PI kW	TC kW	PI kW	TC kW	PI kW	TC kW	PI kW		
130	14.56	10	9.83	1.29	11.7	1.58	13.6	1.88	14.6	2.04	15.5	2.19	16.6	2.27	16.9	2.17		
		12	9.83	1.32	11.7	1.61	13.6	1.92	14.6	2.07	15.5	2.23	16.4	2.26	16.7	2.22		
		14	9.83	1.34	11.7	1.64	13.6	1.96	14.6	2.11	15.5	2.27	16.1	2.33	16.5	2.34		
		16	9.83	1.37	11.7	1.68	13.6	1.99	14.6	2.18	15.5	2.41	15.9	2.45	16.3	2.47		
		18	9.83	1.40	11.7	1.71	13.6	2.12	14.6	2.35	15.4	2.55	15.7	2.57	16.1	2.59		
		20	9.83	1.42	11.7	1.82	13.6	2.28	14.6	2.53	15.2	2.68	15.5	2.70	15.9	2.72		
		21	9.83	1.46	11.7	1.89	13.6	2.37	14.6	2.63	15.0	2.74	15.4	2.76	15.8	2.78		
		23	9.83	1.57	11.7	2.02	13.6	2.54	14.6	2.82	14.8	2.87	15.2	2.89	15.5	2.91		
		25	9.83	1.68	11.7	2.17	13.6	2.72	14.4	2.98	14.6	2.99	15.0	3.02	15.3	3.04		
		27	9.83	1.79	11.7	2.32	13.6	2.91	14.2	3.10	14.4	3.12	14.8	3.14	15.1	3.17		
		29	9.83	1.91	11.7	2.48	13.6	3.12	14.0	3.23	14.2	3.24	14.5	3.27	14.9	3.30		
		31	9.83	2.04	11.7	2.64	13.6	3.33	13.8	3.35	14.0	3.37	14.3	3.40	14.7	3.43		
		33	9.83	2.17	11.7	2.82	13.4	3.46	13.6	3.48	13.8	3.50	14.1	3.53	14.5	3.56		
		35	9.83	2.31	11.7	3.01	13.2	3.59	13.4	3.61	13.6	3.62	13.9	3.65	14.3	3.69		
		37	9.83	2.46	11.7	3.21	13.0	3.72	13.2	3.73	13.3	3.75	13.7	3.78	14.1	3.82		
		39	9.83	2.62	11.7	3.42	12.8	3.84	13.0	3.86	13.1	3.88	13.5	3.91	13.8	3.95		
		120	13.44	10	9.07	1.18	10.8	1.44	12.6	1.72	13.4	1.86	14.3	2.00	16.1	2.28	16.7	2.25
				12	9.07	1.20	10.8	1.47	12.6	1.75	13.4	1.89	14.3	2.03	16.1	2.32	16.4	2.23
14	9.07			1.23	10.8	1.50	12.6	1.78	13.4	1.93	14.3	2.07	15.9	2.32	16.2	2.33		
16	9.07			1.25	10.8	1.53	12.6	1.82	13.4	1.96	14.3	2.13	15.7	2.44	16.0	2.45		
18	9.07			1.27	10.8	1.56	12.6	1.88	13.4	2.08	14.3	2.29	15.5	2.56	15.8	2.58		
20	9.07			1.30	10.8	1.62	12.6	2.02	13.4	2.24	14.3	2.47	15.3	2.69	15.6	2.70		
21	9.07			1.31	10.8	1.68	12.6	2.09	13.4	2.32	14.3	2.56	15.2	2.75	15.5	2.77		
23	9.07			1.40	10.8	1.80	12.6	2.25	13.4	2.49	14.3	2.75	14.9	2.87	15.3	2.89		
25	9.07			1.50	10.8	1.92	12.6	2.41	13.4	2.67	14.3	2.94	14.7	3.00	15.1	3.02		
27	9.07			1.60	10.8	2.06	12.6	2.58	13.4	2.86	14.2	3.10	14.5	3.12	14.8	3.15		
29	9.07			1.70	10.8	2.20	12.6	2.75	13.4	3.06	14.0	3.22	14.3	3.25	14.6	3.28		
31	9.07			1.82	10.8	2.35	12.6	2.94	13.4	3.27	13.8	3.35	14.1	3.38	14.4	3.40		
33	9.07			1.93	10.8	2.50	12.6	3.14	13.4	3.46	13.5	3.48	13.9	3.50	14.2	3.53		
35	9.07			2.06	10.8	2.67	12.6	3.35	13.2	3.59	13.3	3.60	13.7	3.63	14.0	3.66		
37	9.07			2.19	10.8	2.84	12.6	3.58	13.0	3.71	13.1	3.73	13.4	3.76	13.8	3.79		
39	9.07			2.33	10.8	3.03	12.6	3.82	12.7	3.84	12.9	3.86	13.2	3.89	13.6	3.92		
110	12.32			10	8.31	1.07	9.92	1.31	11.5	1.55	12.3	1.68	13.1	1.81	14.7	2.06	16.3	2.32
				12	8.31	1.09	9.92	1.33	11.5	1.58	12.3	1.71	13.1	1.84	14.7	2.10	16.2	2.32
		14	8.31	1.11	9.92	1.36	11.5	1.61	12.3	1.74	13.1	1.87	14.7	2.14	15.9	2.32		
		16	8.31	1.13	9.92	1.38	11.5	1.64	12.3	1.78	13.1	1.91	14.7	2.22	15.7	2.44		
		18	8.31	1.16	9.92	1.41	11.5	1.68	12.3	1.83	13.1	2.01	14.7	2.40	15.5	2.56		
		20	8.31	1.18	9.92	1.44	11.5	1.78	12.3	1.96	13.1	2.16	14.7	2.58	15.3	2.69		
		21	8.31	1.19	9.92	1.48	11.5	1.84	12.3	2.03	13.1	2.24	14.7	2.67	15.2	2.75		
		23	8.31	1.24	9.92	1.59	11.5	1.97	12.3	2.18	13.1	2.40	14.7	2.86	15.0	2.88		
		25	8.31	1.33	9.92	1.70	11.5	2.11	12.3	2.34	13.1	2.57	14.5	2.98	14.8	3.00		
		27	8.31	1.42	9.92	1.81	11.5	2.26	12.3	2.50	13.1	2.75	14.3	3.11	14.6	3.13		
		29	8.31	1.51	9.92	1.94	11.5	2.41	12.3	2.67	13.1	2.94	14.0	3.23	14.3	3.25		
		31	8.31	1.61	9.92	2.06	11.5	2.58	12.3	2.85	13.1	3.15	13.8	3.36	14.1	3.38		
		33	8.31	1.71	9.92	2.20	11.5	2.75	12.3	3.05	13.1	3.36	13.6	3.48	13.9	3.51		
		35	8.31	1.82	9.92	2.34	11.5	2.93	12.3	3.25	13.1	3.58	13.4	3.61	13.7	3.64		
		37	8.31	1.94	9.92	2.50	11.5	3.13	12.3	3.47	12.9	3.71	13.2	3.74	13.5	3.77		
		39	8.31	2.06	9.92	2.66	11.5	3.33	12.3	3.70	12.7	3.83	13.0	3.86	13.3	3.89		
		100	11.20	10	7.56	0.97	9.02	1.17	10.5	1.39	11.2	1.50	11.9	1.62	13.4	1.85	14.8	2.08
				12	7.56	0.99	9.02	1.20	10.5	1.42	11.2	1.53	11.9	1.65	13.4	1.88	14.8	2.12
14	7.56			1.00	9.02	1.22	10.5	1.44	11.2	1.56	11.9	1.68	13.4	1.92	14.8	2.16		
16	7.56			1.02	9.02	1.24	10.5	1.47	11.2	1.59	11.9	1.71	13.4	1.96	14.8	2.25		
18	7.56			1.04	9.02	1.26	10.5	1.50	11.2	1.62	11.9	1.75	13.4	2.07	14.8	2.43		
20	7.56			1.06	9.02	1.29	10.5	1.55	11.2	1.70	11.9	1.87	13.4	2.22	14.8	2.61		
21	7.56			1.07	9.02	1.30	10.5	1.60	11.2	1.77	11.9	1.94	13.4	2.31	14.8	2.71		
23	7.56			1.10	9.02	1.39	10.5	1.72	11.2	1.89	11.9	2.08	13.4	2.47	14.7	2.86		
25	7.56			1.17	9.02	1.48	10.5	1.84	11.2	2.02	11.9	2.22	13.4	2.65	14.5	2.98		
27	7.56			1.25	9.02	1.58	10.5	1.96	11.2	2.17	11.9	2.38	13.4	2.84	14.3	3.11		
29	7.56			1.33	9.02	1.69	10.5	2.09	11.2	2.31	11.9	2.54	13.4	3.04	14.1	3.23		
31	7.56			1.42	9.02	1.80	10.5	2.23	11.2	2.47	11.9	2.72	13.4	3.25	13.9	3.36		
33	7.56			1.51	9.02	1.92	10.5	2.38	11.2	2.64	11.9	2.90	13.4	3.46	13.6	3.48		
35	7.56			1.60	9.02	2.04	10.5	2.54	11.2	2.81	11.9	3.09	13.2	3.59	13.4	3.61		
37	7.56			1.70	9.02	2.17	10.5	2.71	11.2	3.00	11.9	3.30	12.9	3.71	13.2	3.74		
39	7.56			1.80	9.02	2.31	10.5	2.88	11.2	3.19	11.9	3.52	12.7	3.84	13.0	3.87		

4TW30372-1

NOTE

1 The above table shows the average value of conditions which may occur.

3 Capacity tables

3 - 1 Cooling capacity tables

RXYSQ4PAV1			Indoor air temp. (°CWB)													
Combination (%)	Capacity index (kW)	Outdoor air temp.(°CDB)	14.0		16.0		18.0		19.0		20.0		22.0		24.0	
			TC	PI	TC	PI	TC	PI	TC	PI	TC	PI	TC	PI	TC	PI
			kW	kW	kW	kW	kW	kW	kW	kW	kW	kW	kW	kW	kW	kW
90	10.08	10	6.80	0.87	8.11	1.05	9.42	1.23	10.1	1.33	10.7	1.43	12.0	1.64	13.4	1.84
		12	6.80	0.88	8.11	1.06	9.42	1.26	10.1	1.36	10.7	1.46	12.0	1.67	13.4	1.88
		14	6.80	0.90	8.11	1.08	9.42	1.28	10.1	1.38	10.7	1.49	12.0	1.70	13.4	1.91
		16	6.80	0.91	8.11	1.10	9.42	1.30	10.1	1.41	10.7	1.51	12.0	1.73	13.4	1.95
		18	6.80	0.93	8.11	1.12	9.42	1.33	10.1	1.44	10.7	1.54	12.0	1.77	13.4	2.06
		20	6.80	0.95	8.11	1.15	9.42	1.36	10.1	1.47	10.7	1.60	12.0	1.90	13.4	2.22
		21	6.80	0.95	8.11	1.16	9.42	1.38	10.1	1.52	10.7	1.66	12.0	1.97	13.4	2.30
		23	6.80	0.97	8.11	1.20	9.42	1.48	10.1	1.62	10.7	1.78	12.0	2.11	13.4	2.47
		25	6.80	1.02	8.11	1.29	9.42	1.58	10.1	1.74	10.7	1.90	12.0	2.26	13.4	2.64
		27	6.80	1.09	8.11	1.37	9.42	1.69	10.1	1.86	10.7	2.03	12.0	2.42	13.4	2.83
		29	6.80	1.16	8.11	1.46	9.42	1.80	10.1	1.98	10.7	2.17	12.0	2.58	13.4	3.03
		31	6.80	1.23	8.11	1.56	9.42	1.92	10.1	2.11	10.7	2.32	12.0	2.76	13.4	3.24
		33	6.80	1.31	8.11	1.66	9.42	2.04	10.1	2.25	10.7	2.47	12.0	2.94	13.4	3.46
		35	6.80	1.39	8.11	1.76	9.42	2.18	10.1	2.40	10.7	2.64	12.0	3.14	13.2	3.59
		37	6.80	1.48	8.11	1.87	9.42	2.32	10.1	2.56	10.7	2.81	12.0	3.35	12.9	3.71
		39	6.80	1.57	8.11	1.99	9.42	2.47	10.1	2.72	10.7	2.99	12.0	3.57	12.7	3.84
80	8.96	10	6.05	0.77	7.21	0.92	8.38	1.08	8.96	1.17	9.54	1.25	10.7	1.43	11.9	1.61
		12	6.05	0.78	7.21	0.94	8.38	1.10	8.96	1.19	9.54	1.27	10.7	1.45	11.9	1.64
		14	6.05	0.79	7.21	0.95	8.38	1.12	8.96	1.21	9.54	1.30	10.7	1.48	11.9	1.67
		16	6.05	0.81	7.21	0.97	8.38	1.14	8.96	1.23	9.54	1.32	10.7	1.51	11.9	1.70
		18	6.05	0.82	7.21	0.99	8.38	1.16	8.96	1.26	9.54	1.35	10.7	1.54	11.9	1.74
		20	6.05	0.84	7.21	1.01	8.38	1.19	8.96	1.28	9.54	1.38	10.7	1.60	11.9	1.86
		21	6.05	0.84	7.21	1.02	8.38	1.20	8.96	1.29	9.54	1.40	10.7	1.65	11.9	1.92
		23	6.05	0.86	7.21	1.04	8.38	1.26	8.96	1.38	9.54	1.50	10.7	1.77	11.9	2.06
		25	6.05	0.89	7.21	1.10	8.38	1.34	8.96	1.47	9.54	1.61	10.7	1.90	11.9	2.21
		27	6.05	0.94	7.21	1.18	8.38	1.43	8.96	1.57	9.54	1.72	10.7	2.03	11.9	2.36
		29	6.05	1.00	7.21	1.25	8.38	1.53	8.96	1.68	9.54	1.83	10.7	2.16	11.9	2.53
		31	6.05	1.07	7.21	1.33	8.38	1.63	8.96	1.79	9.54	1.95	10.7	2.31	11.9	2.70
		33	6.05	1.13	7.21	1.41	8.38	1.73	8.96	1.90	9.54	2.08	10.7	2.46	11.9	2.88
		35	6.05	1.20	7.21	1.50	8.38	1.84	8.96	2.02	9.54	2.22	10.7	2.63	11.9	3.07
		37	6.05	1.27	7.21	1.60	8.38	1.96	8.96	2.15	9.54	2.36	10.7	2.80	11.9	3.28
		39	6.05	1.35	7.21	1.69	8.38	2.08	8.96	2.29	9.54	2.51	10.7	2.98	11.9	3.49
70	7.84	10	5.29	0.68	6.31	0.80	7.33	0.94	7.84	1.01	8.35	1.08	9.37	1.23	10.4	1.38
		12	5.29	0.69	6.31	0.82	7.33	0.95	7.84	1.02	8.35	1.10	9.37	1.25	10.4	1.40
		14	5.29	0.70	6.31	0.83	7.33	0.97	7.84	1.04	8.35	1.12	9.37	1.27	10.4	1.43
		16	5.29	0.71	6.31	0.84	7.33	0.99	7.84	1.06	8.35	1.14	9.37	1.30	10.4	1.46
		18	5.29	0.72	6.31	0.86	7.33	1.01	7.84	1.08	8.35	1.16	9.37	1.32	10.4	1.49
		20	5.29	0.73	6.31	0.87	7.33	1.02	7.84	1.10	8.35	1.18	9.37	1.35	10.4	1.53
		21	5.29	0.74	6.31	0.88	7.33	1.03	7.84	1.11	8.35	1.19	9.37	1.37	10.4	1.58
		23	5.29	0.75	6.31	0.90	7.33	1.06	7.84	1.15	8.35	1.25	9.37	1.47	10.4	1.70
		25	5.29	0.77	6.31	0.93	7.33	1.13	7.84	1.23	8.35	1.34	9.37	1.57	10.4	1.81
		27	5.29	0.81	6.31	0.99	7.33	1.20	7.84	1.31	8.35	1.43	9.37	1.67	10.4	1.94
		29	5.29	0.86	6.31	1.06	7.33	1.28	7.84	1.40	8.35	1.52	9.37	1.78	10.4	2.07
		31	5.29	0.91	6.31	1.12	7.33	1.36	7.84	1.49	8.35	1.62	9.37	1.90	10.4	2.21
		33	5.29	0.96	6.31	1.19	7.33	1.44	7.84	1.58	8.35	1.72	9.37	2.03	10.4	2.36
		35	5.29	1.02	6.31	1.26	7.33	1.54	7.84	1.68	8.35	1.83	9.37	2.16	10.4	2.51
		37	5.29	1.08	6.31	1.34	7.33	1.63	7.84	1.79	8.35	1.95	9.37	2.30	10.4	2.67
		39	5.29	1.14	6.31	1.42	7.33	1.73	7.84	1.90	8.35	2.07	9.37	2.44	10.4	2.85
60	6.72	10	4.54	0.59	5.41	0.69	6.28	0.80	6.72	0.86	7.16	0.91	8.03	1.03	8.90	1.16
		12	4.54	0.60	5.41	0.70	6.28	0.81	6.72	0.87	7.16	0.93	8.03	1.05	8.90	1.18
		14	4.54	0.61	5.41	0.71	6.28	0.83	6.72	0.89	7.16	0.95	8.03	1.07	8.90	1.20
		16	4.54	0.61	5.41	0.72	6.28	0.84	6.72	0.90	7.16	0.96	8.03	1.09	8.90	1.22
		18	4.54	0.62	5.41	0.74	6.28	0.86	6.72	0.92	7.16	0.98	8.03	1.11	8.90	1.25
		20	4.54	0.63	5.41	0.75	6.28	0.87	6.72	0.93	7.16	1.00	8.03	1.13	8.90	1.27
		21	4.54	0.64	5.41	0.75	6.28	0.88	6.72	0.94	7.16	1.01	8.03	1.14	8.90	1.28
		23	4.54	0.65	5.41	0.77	6.28	0.89	6.72	0.96	7.16	1.03	8.03	1.19	8.90	1.37
		25	4.54	0.66	5.41	0.78	6.28	0.93	6.72	1.01	7.16	1.09	8.03	1.27	8.90	1.46
		27	4.54	0.68	5.41	0.83	6.28	0.99	6.72	1.07	7.16	1.16	8.03	1.35	8.90	1.56
		29	4.54	0.73	5.41	0.88	6.28	1.05	6.72	1.14	7.16	1.24	8.03	1.44	8.90	1.66
		31	4.54	0.77	5.41	0.93	6.28	1.12	6.72	1.21	7.16	1.32	8.03	1.54	8.90	1.77
		33	4.54	0.81	5.41	0.99	6.28	1.19	6.72	1.29	7.16	1.40	8.03	1.63	8.90	1.89
		35	4.54	0.86	5.41	1.05	6.28	1.26	6.72	1.37	7.16	1.49	8.03	1.74	8.90	2.01
		37	4.54	0.91	5.41	1.11	6.28	1.33	6.72	1.45	7.16	1.58	8.03	1.85	8.90	2.13
		39	4.54	0.96	5.41	1.17	6.28	1.41	6.72	1.54	7.16	1.68	8.03	1.96	8.90	2.27
50	5.60	10	3.78	0.51	4.51	0.59	5.24	0.67	5.60	0.71	5.96	0.76	6.69	0.85	7.42	0.95
		12	3.78	0.51	4.51	0.59	5.24	0.68	5.60	0.73	5.96	0.77	6.69	0.87	7.42	0.97
		14	3.78	0.52	4.51	0.60	5.24	0.69	5.60	0.74	5.96	0.78	6.69	0.88	7.42	0.98
		16	3.78	0.53	4.51	0.61	5.24	0.70	5.60	0.75	5.96	0.80	6.69	0.90	7.42	1.00
		18	3.78	0.53	4.51	0.62	5.24	0.71	5.60	0.76	5.96	0.81	6.69	0.91	7.42	1.02
		20	3.78	0.54	4.51	0.63	5.24	0.73	5.60	0.77	5.96	0.83	6.69	0.93	7.42	1.04
		21	3.78	0.55	4.51	0.64	5.24	0.73	5.60	0.78	5.96	0.83	6.69	0.94	7.42	1.05
		23	3.78	0.55	4.51	0.65	5.24	0.74	5.60	0.80	5.96	0.85	6.69	0.96	7.42	1.07
		25	3.78	0.56	4.51	0.66	5.24	0.76	5.60	0.81	5.96	0.87	6.69	1.00	7.42	1.14
		27	3.78	0.57	4.51	0.68	5.24	0.80	5.60	0.86	5.96	0.93	6.69	1.07	7.42	1.22
		29	3.78	0.60	4.51	0.72	5.24	0.85	5.60	0.92	5.96	0.99	6.69	1.14	7.42	1.30
		31	3.78	0.64	4.51											

3 Capacity tables

3 - 1 Cooling capacity tables

RXYSQ5PAV1			TC: Total capacity (kW); PI: Power Input (kW) (Compressor + Outdoor fan motor)															
Combination (%)	Capacity index (kW)	Outdoor air temp.(°CDB)	Indoor air temp. (°CWB)															
			14.0		16.0		18.0		19.0		20.0		22.0		24.0			
			TC	PI	TC	PI	TC	PI	TC	PI	TC	PI	TC	PI	TC	PI		
			kW	kW	kW	kW	kW	kW	kW	kW	kW	kW	kW	kW	kW			
130	18.20	10	12.3	1.62	14.7	1.98	17.0	2.35	18.2	2.54	19.1	2.67	19.6	2.55	20.0	2.44		
		12	12.3	1.65	14.7	2.02	17.0	2.40	18.2	2.59	18.9	2.65	19.3	2.54	19.8	2.49		
		14	12.3	1.68	14.7	2.05	17.0	2.44	18.2	2.64	18.6	2.64	19.1	2.61	19.5	2.64		
		16	12.3	1.71	14.7	2.09	17.0	2.49	18.2	2.72	18.4	2.73	18.8	2.75	19.3	2.78		
		18	12.3	1.74	14.7	2.14	17.0	2.65	17.9	2.86	18.1	2.87	18.6	2.90	19.0	2.92		
		20	12.3	1.78	14.7	2.28	17.0	2.85	17.7	3.00	17.9	3.01	18.3	3.04	18.8	3.06		
		21	12.3	1.83	14.7	2.36	17.0	2.96	17.5	3.07	17.8	3.08	18.2	3.11	18.7	3.13		
		23	12.3	1.96	14.7	2.53	17.0	3.17	17.3	3.21	17.5	3.22	18.0	3.25	18.4	3.28		
		25	12.3	2.09	14.7	2.71	16.8	3.33	17.1	3.35	17.3	3.36	17.7	3.39	18.2	3.42		
		27	12.3	2.24	14.7	2.89	16.6	3.47	16.8	3.49	17.0	3.50	17.5	3.54	17.9	3.57		
		29	12.3	2.39	14.7	3.09	16.3	3.61	16.6	3.63	16.8	3.65	17.2	3.68	17.7	3.71		
		31	12.3	2.54	14.7	3.30	16.1	3.75	16.3	3.77	16.5	3.79	17.0	3.82	17.4	3.86		
		33	12.3	2.71	14.7	3.53	15.8	3.89	16.1	3.91	16.3	3.93	16.7	3.97	17.2	4.01		
		35	12.3	2.89	14.7	3.76	15.6	4.04	15.8	4.06	16.0	4.08	16.5	4.12	16.9	4.16		
		37	12.3	3.08	14.7	4.01	15.3	4.18	15.6	4.20	15.8	4.22	16.2	4.26	16.7	4.31		
		39	12.3	3.27	14.7	4.28	15.1	4.32	15.3	4.34	15.5	4.37	16.0	4.41	16.4	4.46		
120	16.80	10	11.3	1.48	13.5	1.80	15.7	2.14	16.8	2.32	17.9	2.49	19.3	2.64	19.7	2.53		
		12	11.3	1.50	13.5	1.84	15.7	2.19	16.8	2.36	17.9	2.54	19.0	2.62	19.4	2.51		
		14	11.3	1.53	13.5	1.87	15.7	2.23	16.8	2.41	17.9	2.59	18.8	2.60	19.2	2.62		
		16	11.3	1.56	13.5	1.91	15.7	2.27	16.8	2.45	17.9	2.66	18.5	2.74	18.9	2.76		
		18	11.3	1.59	13.5	1.95	15.7	2.35	16.8	2.60	17.9	2.86	18.3	2.88	18.7	2.90		
		20	11.3	1.62	13.5	2.02	15.7	2.52	16.8	2.80	17.6	2.99	18.0	3.02	18.4	3.04		
		21	11.3	1.64	13.5	2.10	15.7	2.62	16.8	2.90	17.5	3.06	17.9	3.09	18.3	3.11		
		23	11.3	1.75	13.5	2.25	15.7	2.81	16.8	3.11	17.2	3.20	17.7	3.23	18.1	3.26		
		25	11.3	1.87	13.5	2.40	15.7	3.01	16.8	3.33	17.0	3.34	17.4	3.37	17.8	3.40		
		27	11.3	2.00	13.5	2.57	15.7	3.22	16.5	3.47	16.7	3.48	17.2	3.51	17.6	3.54		
		29	11.3	2.13	13.5	2.74	15.7	3.44	16.3	3.61	16.5	3.62	16.9	3.66	17.3	3.69		
		31	11.3	2.27	13.5	2.93	15.7	3.68	16.0	3.75	16.3	3.77	16.7	3.80	17.1	3.83		
		33	11.3	2.42	13.5	3.12	15.6	3.87	15.8	3.89	16.0	3.91	16.4	3.94	16.8	3.98		
		35	11.3	2.57	13.5	3.33	15.3	4.01	15.5	4.03	15.8	4.05	16.2	4.09	16.6	4.12		
		37	11.3	2.74	13.5	3.55	15.1	4.15	15.3	4.17	15.5	4.19	15.9	4.23	16.3	4.27		
		39	11.3	2.91	13.5	3.78	14.8	4.30	15.1	4.32	15.3	4.34	15.7	4.38	16.1	4.42		
110	15.40	10	10.4	1.34	12.4	1.63	14.4	1.94	15.4	2.10	16.4	2.26	18.4	2.58	19.3	2.62		
		12	10.4	1.37	12.4	1.66	14.4	1.98	15.4	2.14	16.4	2.30	18.4	2.62	19.1	2.60		
		14	10.4	1.39	12.4	1.69	14.4	2.01	15.4	2.18	16.4	2.34	18.4	2.67	18.8	2.60		
		16	10.4	1.42	12.4	1.73	14.4	2.05	15.4	2.22	16.4	2.39	18.2	2.72	18.6	2.74		
		18	10.4	1.44	12.4	1.76	14.4	2.09	15.4	2.28	16.4	2.51	18.0	2.86	18.3	2.88		
		20	10.4	1.47	12.4	1.80	14.4	2.22	15.4	2.45	16.4	2.70	17.7	3.00	18.1	3.02		
		21	10.4	1.49	12.4	1.85	14.4	2.30	15.4	2.54	16.4	2.79	17.6	3.07	18.0	3.09		
		23	10.4	1.55	12.4	1.98	14.4	2.46	15.4	2.72	16.4	3.00	17.3	3.21	17.7	3.23		
		25	10.4	1.66	12.4	2.12	14.4	2.64	15.4	2.92	16.4	3.21	17.1	3.35	17.5	3.38		
		27	10.4	1.77	12.4	2.26	14.4	2.82	15.4	3.12	16.4	3.44	16.8	3.49	17.2	3.52		
		29	10.4	1.89	12.4	2.42	14.4	3.01	15.4	3.34	16.2	3.60	16.6	3.63	17.0	3.66		
		31	10.4	2.01	12.4	2.58	14.4	3.22	15.4	3.57	16.0	3.74	16.3	3.77	16.7	3.80		
		33	10.4	2.14	12.4	2.75	14.4	3.43	15.4	3.81	15.7	3.88	16.1	3.92	16.5	3.95		
		35	10.4	2.28	12.4	2.93	14.4	3.66	15.3	4.01	15.5	4.02	15.8	4.06	16.2	4.09		
		37	10.4	2.42	12.4	3.12	14.4	3.91	15.0	4.15	15.2	4.17	15.6	4.20	16.0	4.24		
		39	10.4	2.57	12.4	3.32	14.4	4.16	14.8	4.29	15.0	4.31	15.4	4.35	15.7	4.39		
100	14.00	10	9.45	1.21	11.3	1.47	13.1	1.74	14.0	1.88	14.9	2.02	16.7	2.31	18.6	2.60		
		12	9.45	1.23	11.3	1.49	13.1	1.77	14.0	1.91	14.9	2.06	16.7	2.35	18.6	2.65		
		14	9.45	1.25	11.3	1.52	13.1	1.80	14.0	1.95	14.9	2.10	16.7	2.40	18.5	2.68		
		16	9.45	1.28	11.3	1.55	13.1	1.84	14.0	1.99	14.9	2.14	16.7	2.44	18.2	2.72		
		18	9.45	1.30	11.3	1.58	13.1	1.88	14.0	2.03	14.9	2.18	16.7	2.58	18.0	2.86		
		20	9.45	1.32	11.3	1.61	13.1	1.93	14.0	2.13	14.9	2.34	16.7	2.78	17.7	3.00		
		21	9.45	1.34	11.3	1.63	13.1	2.00	14.0	2.20	14.9	2.42	16.7	2.88	17.6	3.07		
		23	9.45	1.37	11.3	1.74	13.1	2.14	14.0	2.36	14.9	2.59	16.7	3.09	17.4	3.21		
		25	9.45	1.46	11.3	1.85	13.1	2.29	14.0	2.53	14.9	2.78	16.7	3.31	17.1	3.35		
		27	9.45	1.56	11.3	1.98	13.1	2.45	14.0	2.70	14.9	2.97	16.5	3.47	16.9	3.49		
		29	9.45	1.66	11.3	2.11	13.1	2.62	14.0	2.89	14.9	3.18	16.3	3.61	16.6	3.63		
		31	9.45	1.77	11.3	2.25	13.1	2.79	14.0	3.08	14.9	3.39	16.0	3.75	16.4	3.78		
		33	9.45	1.88	11.3	2.40	13.1	2.98	14.0	3.29	14.9	3.62	15.8	3.89	16.1	3.92		
		35	9.45	2.00	11.3	2.55	13.1	3.17	14.0	3.51	14.9	3.86	15.5	4.03	15.9	4.06		
		37	9.45	2.12	11.3	2.71	13.1	3.38	14.0	3.74	14.9	4.12	15.3	4.17	15.6	4.21		
		39	9.45	2.25	11.3	2.89	13.1	3.60	14.0	3.99	14.7	4.28	15.0	4.32	15.4	4.35		

4TW30372-1

NOTE

1 The above table shows the average value of conditions which may occur.

3 Capacity tables

3 - 1 Cooling capacity tables

RXYSQ5PAV1			Indoor air temp. (°CWB)															
Combination (%)	Capacity index (kW)	Outdoor air temp.(°CDB)	14.0		16.0		18.0		19.0		20.0		22.0		24.0			
			TC	PI	TC	PI	TC	PI	TC	PI	TC	PI	TC	PI	TC	PI		
			kW	kW	kW	kW	kW	kW	kW	kW	kW	kW	kW	kW	kW	kW	kW	
90	12.60	10	8.50	1.08	10.1	1.31	11.8	1.54	12.6	1.66	13.4	1.79	15.1	2.04	16.7	2.30		
		12	8.50	1.10	10.1	1.33	11.8	1.57	12.6	1.69	13.4	1.82	15.1	2.08	16.7	2.35		
		14	8.50	1.12	10.1	1.35	11.8	1.60	12.6	1.73	13.4	1.86	15.1	2.12	16.7	2.39		
		16	8.50	1.14	10.1	1.38	11.8	1.63	12.6	1.76	13.4	1.89	15.1	2.16	16.7	2.44		
		18	8.50	1.16	10.1	1.40	11.8	1.66	12.6	1.79	13.4	1.93	15.1	2.21	16.7	2.58		
		20	8.50	1.18	10.1	1.43	11.8	1.69	12.6	1.83	13.4	2.00	15.1	2.37	16.7	2.77		
		21	8.50	1.19	10.1	1.45	11.8	1.72	12.6	1.89	13.4	2.07	15.1	2.46	16.7	2.87		
		23	8.50	1.22	10.1	1.51	11.8	1.85	12.6	2.03	13.4	2.22	15.1	2.63	16.7	3.08		
		25	8.50	1.28	10.1	1.61	11.8	1.97	12.6	2.17	13.4	2.38	15.1	2.82	16.7	3.30		
		27	8.50	1.36	10.1	1.71	11.8	2.11	12.6	2.32	13.4	2.54	15.1	3.02	16.5	3.47		
		29	8.50	1.45	10.1	1.83	11.8	2.25	12.6	2.47	13.4	2.71	15.1	3.22	16.3	3.61		
		31	8.50	1.54	10.1	1.94	11.8	2.40	12.6	2.64	13.4	2.90	15.1	3.44	16.0	3.75		
		33	8.50	1.64	10.1	2.07	11.8	2.55	12.6	2.81	13.4	3.09	15.1	3.68	15.8	3.89		
		35	8.50	1.74	10.1	2.20	11.8	2.72	12.6	3.00	13.4	3.29	15.1	3.92	15.5	4.03		
		37	8.50	1.85	10.1	2.34	11.8	2.89	12.6	3.19	13.4	3.51	15.0	4.14	15.3	4.17		
		39	8.50	1.96	10.1	2.49	11.8	3.08	12.6	3.40	13.4	3.74	14.7	4.28	15.0	4.31		
		80	11.20	10	7.56	0.96	9.02	1.15	10.5	1.35	11.2	1.46	11.9	1.56	13.4	1.78	14.8	2.01
				12	7.56	0.98	9.02	1.17	10.5	1.38	11.2	1.48	11.9	1.59	13.4	1.82	14.8	2.05
14	7.56			0.99	9.02	1.19	10.5	1.40	11.2	1.51	11.9	1.62	13.4	1.85	14.8	2.09		
16	7.56			1.01	9.02	1.21	10.5	1.43	11.2	1.54	11.9	1.65	13.4	1.89	14.8	2.13		
18	7.56			1.03	9.02	1.23	10.5	1.46	11.2	1.57	11.9	1.69	13.4	1.92	14.8	2.17		
20	7.56			1.05	9.02	1.26	10.5	1.48	11.2	1.60	11.9	1.72	13.4	1.99	14.8	2.32		
21	7.56			1.05	9.02	1.27	10.5	1.50	11.2	1.62	11.9	1.75	13.4	2.07	14.8	2.40		
23	7.56			1.07	9.02	1.29	10.5	1.57	11.2	1.72	11.9	1.88	13.4	2.21	14.8	2.58		
25	7.56			1.11	9.02	1.38	10.5	1.68	11.2	1.84	11.9	2.01	13.4	2.37	14.8	2.76		
27	7.56			1.18	9.02	1.47	10.5	1.79	11.2	1.96	11.9	2.14	13.4	2.53	14.8	2.95		
29	7.56			1.25	9.02	1.56	10.5	1.91	11.2	2.09	11.9	2.29	13.4	2.70	14.8	3.15		
31	7.56			1.33	9.02	1.66	10.5	2.03	11.2	2.23	11.9	2.44	13.4	2.89	14.8	3.37		
33	7.56			1.41	9.02	1.77	10.5	2.16	11.2	2.38	11.9	2.60	13.4	3.08	14.8	3.60		
35	7.56			1.50	9.02	1.88	10.5	2.30	11.2	2.53	11.9	2.77	13.4	3.28	14.8	3.84		
37	7.56			1.59	9.02	1.99	10.5	2.45	11.2	2.69	11.9	2.95	13.4	3.50	14.8	4.09		
39	7.56			1.68	9.02	2.12	10.5	2.60	11.2	2.86	11.9	3.14	13.4	3.72	14.7	4.28		
70	9.80			10	6.61	0.85	7.89	1.00	9.16	1.17	9.80	1.26	10.4	1.35	11.7	1.53	13.0	1.72
				12	6.61	0.86	7.89	1.02	9.16	1.19	9.80	1.28	10.4	1.37	11.7	1.56	13.0	1.75
		14	6.61	0.87	7.89	1.04	9.16	1.21	9.80	1.30	10.4	1.40	11.7	1.59	13.0	1.79		
		16	6.61	0.89	7.89	1.05	9.16	1.23	9.80	1.33	10.4	1.42	11.7	1.62	13.0	1.82		
		18	6.61	0.90	7.89	1.07	9.16	1.26	9.80	1.35	10.4	1.45	11.7	1.65	13.0	1.86		
		20	6.61	0.92	7.89	1.09	9.16	1.28	9.80	1.38	10.4	1.48	11.7	1.68	13.0	1.91		
		21	6.61	0.92	7.89	1.10	9.16	1.29	9.80	1.39	10.4	1.49	11.7	1.71	13.0	1.98		
		23	6.61	0.94	7.89	1.12	9.16	1.32	9.80	1.44	10.4	1.56	11.7	1.83	13.0	2.12		
		25	6.61	0.96	7.89	1.17	9.16	1.41	9.80	1.54	10.4	1.67	11.7	1.96	13.0	2.27		
		27	6.61	1.01	7.89	1.24	9.16	1.50	9.80	1.64	10.4	1.78	11.7	2.09	13.0	2.42		
		29	6.61	1.07	7.89	1.32	9.16	1.60	9.80	1.74	10.4	1.90	11.7	2.23	13.0	2.59		
		31	6.61	1.14	7.89	1.40	9.16	1.70	9.80	1.86	10.4	2.02	11.7	2.38	13.0	2.76		
		33	6.61	1.20	7.89	1.49	9.16	1.80	9.80	1.97	10.4	2.15	11.7	2.53	13.0	2.94		
		35	6.61	1.28	7.89	1.58	9.16	1.92	9.80	2.10	10.4	2.29	11.7	2.70	13.0	3.14		
		37	6.61	1.35	7.89	1.68	9.16	2.04	9.80	2.23	10.4	2.43	11.7	2.87	13.0	3.34		
		39	6.61	1.43	7.89	1.78	9.16	2.16	9.80	2.37	10.4	2.59	11.7	3.05	13.0	3.56		
		60	8.40	10	5.67	0.74	6.76	0.86	7.85	1.00	8.40	1.07	8.95	1.14	10.0	1.29	11.1	1.45
				12	5.67	0.75	6.76	0.88	7.85	1.01	8.40	1.09	8.95	1.16	10.0	1.31	11.1	1.47
14	5.67			0.76	6.76	0.89	7.85	1.03	8.40	1.11	8.95	1.18	10.0	1.34	11.1	1.50		
16	5.67			0.77	6.76	0.90	7.85	1.05	8.40	1.13	8.95	1.20	10.0	1.36	11.1	1.53		
18	5.67			0.78	6.76	0.92	7.85	1.07	8.40	1.15	8.95	1.22	10.0	1.39	11.1	1.56		
20	5.67			0.79	6.76	0.93	7.85	1.09	8.40	1.17	8.95	1.25	10.0	1.42	11.1	1.59		
21	5.67			0.80	6.76	0.94	7.85	1.10	8.40	1.18	8.95	1.26	10.0	1.43	11.1	1.60		
23	5.67			0.81	6.76	0.96	7.85	1.12	8.40	1.20	8.95	1.28	10.0	1.48	11.1	1.71		
25	5.67			0.82	6.76	0.98	7.85	1.16	8.40	1.26	8.95	1.36	10.0	1.59	11.1	1.82		
27	5.67			0.85	6.76	1.04	7.85	1.24	8.40	1.34	8.95	1.45	10.0	1.69	11.1	1.95		
29	5.67			0.91	6.76	1.10	7.85	1.31	8.40	1.43	8.95	1.55	10.0	1.80	11.1	2.07		
31	5.67			0.96	6.76	1.17	7.85	1.40	8.40	1.52	8.95	1.65	10.0	1.92	11.1	2.21		
33	5.67			1.01	6.76	1.24	7.85	1.48	8.40	1.61	8.95	1.75	10.0	2.04	11.1	2.35		
35	5.67			1.07	6.76	1.31	7.85	1.57	8.40	1.71	8.95	1.86	10.0	2.17	11.1	2.51		
37	5.67			1.13	6.76	1.39	7.85	1.67	8.40	1.82	8.95	1.97	10.0	2.31	11.1	2.67		
39	5.67			1.20	6.76	1.47	7.85	1.77	8.40	1.93	8.95	2.09	10.0	2.45	11.1	2.84		
50	7.00			10	4.72	0.63	5.63	0.73	6.54	0.84	7.00	0.89	7.46	0.95	8.37	1.06	9.28	1.19
				12	4.72	0.64	5.63	0.74	6.54	0.85	7.00	0.91	7.46	0.96	8.37	1.08	9.28	1.21
		14	4.72	0.65	5.63	0.75	6.54	0.86	7.00	0.92	7.46	0.98	8.37	1.10	9.28	1.23		
		16	4.72	0.66	5.63	0.76	6.54	0.88	7.00	0.94	7.46	1.00	8.37	1.12	9.28	1.25		
		18	4.72	0.67	5.63	0.78	6.54	0.89	7.00	0.95	7.46	1.01	8.37	1.14	9.28	1.27		
		20	4.72	0.68	5.63	0.79	6.54	0.91	7.00	0.97	7.46	1.03	8.37	1.16	9.28	1.30		
		21	4.72	0.68	5.63	0.79	6.54	0.91	7.00	0.98	7.46	1.04	8.37	1.17	9.28	1.31		
		23	4.72	0.69	5.63	0.81	6.54	0.93	7.00	0.99	7.46	1.06	8.37	1.19	9.28	1.34		
		25	4.72	0.70	5.63	0.82	6.54	0.95	7.00	1.01	7.46	1.09	8.37	1.25	9.28	1.43		
		27	4.72	0.71	5.63	0.85	6.54	1.00	7.00	1.08	7.46	1.16	8.37	1.34	9.28	1.52		
		29	4.72	0.75	5.63	0.90	6.54	1.06	7.00	1.14	7.46	1.23	8.37	1.42	9.28	1.62		
		31	4.72	0.80	5.63													

3 Capacity tables

3 - 1 Cooling capacity tables

RXYSQ6PAV1			TC: Total capacity (kW); PI: Power Input (kW) (Compressor + Outdoor fan motor)															
Combination (%)	Capacity index (kW)	Outdoor air temp. (°CDB)	Indoor air temp. (°CWB)															
			14.0		16.0		18.0		19.0		20.0		22.0		24.0			
			TC	PI	TC	PI	TC	PI	TC	PI	TC	PI	TC	PI	TC	PI		
			kW	kW	kW	kW	kW	kW	kW	kW	kW	kW	kW	kW	kW			
130	20.15	10	13.6	2.09	16.2	2.55	18.8	3.04	20.2	3.28	20.4	3.22	20.9	3.08	21.4	2.94		
		12	13.6	2.12	16.2	2.60	18.8	3.09	19.9	3.27	20.1	3.20	20.6	3.06	21.1	3.01		
		14	13.6	2.16	16.2	2.65	18.8	3.15	19.6	3.25	19.9	3.18	20.4	3.15	20.9	3.18		
		16	13.6	2.21	16.2	2.70	18.8	3.21	19.4	3.28	19.6	3.29	20.1	3.32	20.6	3.35		
		18	13.6	2.25	16.2	2.76	18.8	3.42	19.1	3.44	19.3	3.46	19.8	3.49	20.3	3.52		
		20	13.6	2.29	16.2	2.94	18.6	3.59	18.8	3.61	19.1	3.63	19.6	3.66	20.1	3.70		
		21	13.6	2.36	16.2	3.04	18.5	3.68	18.7	3.70	19.0	3.71	19.4	3.75	19.9	3.78		
		23	13.6	2.53	16.2	3.26	18.2	3.85	18.4	3.86	18.7	3.88	19.2	3.92	19.7	3.96		
		25	13.6	2.70	16.2	3.49	17.9	4.01	18.2	4.03	18.4	4.05	18.9	4.09	19.4	4.13		
		27	13.6	2.88	16.2	3.74	17.7	4.18	17.9	4.20	18.2	4.22	18.7	4.27	19.1	4.31		
		29	13.6	3.08	16.2	3.99	17.4	4.35	17.7	4.37	17.9	4.40	18.4	4.44	18.9	4.48		
		31	13.6	3.28	16.2	4.26	17.2	4.52	17.4	4.54	17.6	4.57	18.1	4.61	18.6	4.66		
		33	13.6	3.50	16.2	4.55	16.9	4.69	17.1	4.72	17.4	4.74	17.9	4.79	18.4	4.84		
		35	13.6	3.73	16.1	4.81	16.6	4.86	16.9	4.89	17.1	4.91	17.6	4.97	18.1	5.02		
		37	13.6	3.97	15.9	4.98	16.4	5.04	16.6	5.06	16.9	5.09	17.3	5.14	17.8	5.20		
		39	13.6	4.23	15.6	5.15	16.1	5.21	16.4	5.24	16.6	5.27	17.1	5.32	17.6	5.38		
120	18.60	10	12.6	1.91	15.0	2.33	17.4	2.77	18.6	2.99	19.8	3.22	20.5	3.18	21.0	3.05		
		12	12.6	1.94	15.0	2.37	17.4	2.82	18.6	3.05	19.8	3.28	20.3	3.16	20.7	3.03		
		14	12.6	1.98	15.0	2.42	17.4	2.87	18.6	3.11	19.6	3.27	20.0	3.14	20.5	3.16		
		16	12.6	2.01	15.0	2.46	17.4	2.93	18.6	3.17	19.3	3.27	19.8	3.30	20.2	3.33		
		18	12.6	2.05	15.0	2.51	17.4	3.03	18.6	3.36	19.0	3.44	19.5	3.47	19.9	3.50		
		20	12.6	2.09	15.0	2.61	17.4	3.26	18.6	3.59	18.8	3.61	19.2	3.64	19.7	3.67		
		21	12.6	2.11	15.0	2.71	17.4	3.38	18.4	3.67	18.6	3.69	19.1	3.72	19.6	3.76		
		23	12.6	2.26	15.0	2.90	17.4	3.62	18.2	3.84	18.4	3.86	18.8	3.89	19.3	3.93		
		25	12.6	2.41	15.0	3.10	17.4	3.88	17.9	4.01	18.1	4.03	18.6	4.06	19.0	4.10		
		27	12.6	2.58	15.0	3.32	17.4	4.15	17.6	4.18	17.9	4.20	18.3	4.24	18.8	4.27		
		29	12.6	2.75	15.0	3.54	17.1	4.33	17.4	4.35	17.6	4.37	18.1	4.41	18.5	4.45		
		31	12.6	2.93	15.0	3.78	16.9	4.50	17.1	4.52	17.3	4.54	17.8	4.58	18.2	4.62		
		33	12.6	3.12	15.0	4.03	16.6	4.66	16.8	4.69	17.1	4.71	17.5	4.76	18.0	4.80		
		35	12.6	3.32	15.0	4.30	16.4	4.83	16.6	4.86	16.8	4.88	17.3	4.93	17.7	4.98		
		37	12.6	3.53	15.0	4.58	16.1	5.00	16.3	5.03	16.5	5.06	17.0	5.11	17.5	5.16		
		39	12.6	3.76	15.0	4.88	15.8	5.18	16.1	5.20	16.3	5.23	16.7	5.28	17.2	5.34		
110	17.05	10	11.5	1.73	13.7	2.11	15.9	2.50	17.1	2.71	18.2	2.91	20.2	3.27	20.6	3.16		
		12	11.5	1.76	13.7	2.15	15.9	2.55	17.1	2.76	18.2	2.97	19.9	3.25	20.3	3.14		
		14	11.5	1.79	13.7	2.19	15.9	2.60	17.1	2.81	18.2	3.02	19.7	3.24	20.1	3.14		
		16	11.5	1.83	13.7	2.23	15.9	2.65	17.1	2.86	18.2	3.08	19.4	3.28	19.8	3.30		
		18	11.5	1.86	13.7	2.27	15.9	2.70	17.1	2.94	18.2	3.24	19.1	3.45	19.6	3.47		
		20	11.5	1.90	13.7	2.32	15.9	2.86	17.1	3.16	18.2	3.48	18.9	3.61	19.3	3.64		
		21	11.5	1.92	13.7	2.39	15.9	2.97	17.1	3.28	18.2	3.60	18.8	3.70	19.2	3.73		
		23	11.5	2.01	13.7	2.56	15.9	3.18	17.1	3.51	18.1	3.84	18.5	3.87	18.9	3.90		
		25	11.5	2.14	13.7	2.74	15.9	3.40	17.1	3.76	17.8	4.00	18.2	4.04	18.6	4.07		
		27	11.5	2.29	13.7	2.92	15.9	3.64	17.1	4.03	17.6	4.17	18.0	4.21	18.4	4.24		
		29	11.5	2.44	13.7	3.12	15.9	3.89	17.1	4.31	17.3	4.34	17.7	4.38	18.1	4.41		
		31	11.5	2.59	13.7	3.33	15.9	4.15	16.8	4.49	17.0	4.51	17.4	4.55	17.9	4.59		
		33	11.5	2.76	13.7	3.55	15.9	4.43	16.6	4.66	16.8	4.68	17.2	4.72	17.6	4.76		
		35	11.5	2.94	13.7	3.78	15.9	4.73	16.3	4.83	16.5	4.85	16.9	4.89	17.3	4.94		
		37	11.5	3.12	13.7	4.02	15.8	4.97	16.0	5.00	16.2	5.02	16.7	5.07	17.1	5.11		
		39	11.5	3.32	13.7	4.28	15.6	5.14	15.8	5.17	16.0	5.19	16.4	5.24	16.8	5.29		
100	15.50	10	10.5	1.56	12.5	1.89	14.5	2.24	15.5	2.42	16.5	2.61	18.5	2.98	20.2	3.26		
		12	10.5	1.59	12.5	1.93	14.5	2.28	15.5	2.47	16.5	2.66	18.5	3.03	20.0	3.25		
		14	10.5	1.62	12.5	1.96	14.5	2.33	15.5	2.52	16.5	2.71	18.5	3.09	19.7	3.23		
		16	10.5	1.65	12.5	2.00	14.5	2.37	15.5	2.56	16.5	2.76	18.5	3.15	19.4	3.28		
		18	10.5	1.68	12.5	2.04	14.5	2.42	15.5	2.62	16.5	2.81	18.5	3.33	19.2	3.45		
		20	10.5	1.71	12.5	2.08	14.5	2.49	15.5	2.75	16.5	3.01	18.5	3.59	18.9	3.62		
		21	10.5	1.72	12.5	2.10	14.5	2.58	15.5	2.85	16.5	3.12	18.4	3.67	18.8	3.70		
		23	10.5	1.77	12.5	2.24	14.5	2.77	15.5	3.05	16.5	3.35	18.1	3.84	18.5	3.87		
		25	10.5	1.89	12.5	2.39	14.5	2.96	15.5	3.26	16.5	3.59	17.9	4.01	18.3	4.04		
		27	10.5	2.01	12.5	2.55	14.5	3.16	15.5	3.49	16.5	3.84	17.6	4.18	18.0	4.21		
		29	10.5	2.14	12.5	2.72	14.5	3.38	15.5	3.73	16.5	4.10	17.4	4.35	17.7	4.38		
		31	10.5	2.28	12.5	2.90	14.5	3.60	15.5	3.98	16.5	4.38	17.1	4.52	17.5	4.55		
		33	10.5	2.43	12.5	3.09	14.5	3.84	15.5	4.25	16.5	4.65	16.8	4.69	17.2	4.72		
		35	10.5	2.58	12.5	3.29	14.5	4.09	15.5	4.53	16.2	4.82	16.6	4.86	16.9	4.90		
		37	10.5	2.74	12.5	3.50	14.5	4.36	15.5	4.83	15.9	4.99	16.3	5.03	16.7	5.07		
		39	10.5	2.91	12.5	3.73	14.5	4.65	15.5	5.13	15.7	5.16	16.0	5.20	16.4	5.25		

4TW30372-1

NOTE

1 The above table shows the average value of conditions which may occur.

3 Capacity tables

3 - 1 Cooling capacity tables

RXYSQ6PAV1			TC: Total capacity (kW); PI: Power Input (kW) (Compressor + Outdoor fan motor)															
Combination (%)	Capacity index (kW)	Outdoor air temp.(°CDB)	Indoor air temp. (°CWB)															
			14.0		16.0		18.0		19.0		20.0		22.0		24.0			
			TC	PI	TC	PI	TC	PI	TC	PI	TC	PI	TC	PI	TC	PI		
			kW	kW	kW	kW	kW	kW	kW	kW	kW	kW	kW	kW	kW			
90	13.95	10	9.41	1.40	11.2	1.69	13.0	1.99	14.0	2.15	14.9	2.31	16.7	2.64	18.5	2.97		
		12	9.41	1.42	11.2	1.72	13.0	2.03	14.0	2.19	14.9	2.35	16.7	2.69	18.5	3.03		
		14	9.41	1.45	11.2	1.75	13.0	2.06	14.0	2.23	14.9	2.40	16.7	2.74	18.5	3.09		
		16	9.41	1.47	11.2	1.78	13.0	2.10	14.0	2.27	14.9	2.44	16.7	2.79	18.5	3.15		
		18	9.41	1.50	11.2	1.81	13.0	2.14	14.0	2.32	14.9	2.49	16.7	2.85	18.5	3.32		
		20	9.41	1.53	11.2	1.85	13.0	2.19	14.0	2.36	14.9	2.58	16.7	3.06	18.5	3.57		
		21	9.41	1.54	11.2	1.87	13.0	2.23	14.0	2.44	14.9	2.68	16.7	3.17	18.4	3.67		
		23	9.41	1.57	11.2	1.94	13.0	2.38	14.0	2.62	14.9	2.87	16.7	3.40	18.1	3.84		
		25	9.41	1.65	11.2	2.07	13.0	2.55	14.0	2.80	14.9	3.07	16.7	3.64	17.9	4.01		
		27	9.41	1.76	11.2	2.21	13.0	2.72	14.0	2.99	14.9	3.28	16.7	3.89	17.6	4.18		
		29	9.41	1.87	11.2	2.36	13.0	2.90	14.0	3.19	14.9	3.50	16.7	4.16	17.4	4.35		
		31	9.41	1.99	11.2	2.51	13.0	3.09	14.0	3.41	14.9	3.74	16.7	4.45	17.1	4.51		
		33	9.41	2.11	11.2	2.67	13.0	3.29	14.0	3.63	14.9	3.99	16.5	4.65	16.8	4.68		
		35	9.41	2.24	11.2	2.84	13.0	3.51	14.0	3.87	14.9	4.25	16.2	4.82	16.6	4.86		
		37	9.41	2.38	11.2	3.02	13.0	3.73	14.0	4.12	14.9	4.53	16.0	4.99	16.3	5.03		
		39	9.41	2.53	11.2	3.21	13.0	3.97	14.0	4.39	14.9	4.83	15.7	5.16	16.0	5.20		
		80	12.40	10	8.37	1.24	10.0	1.49	11.6	1.75	12.4	1.88	13.2	2.02	14.8	2.30	16.4	2.59
				12	8.37	1.26	10.0	1.51	11.6	1.78	12.4	1.91	13.2	2.05	14.8	2.34	16.4	2.64
14	8.37			1.28	10.0	1.54	11.6	1.81	12.4	1.95	13.2	2.09	14.8	2.39	16.4	2.69		
16	8.37			1.30	10.0	1.56	11.6	1.84	12.4	1.99	13.2	2.13	14.8	2.44	16.4	2.74		
18	8.37			1.33	10.0	1.59	11.6	1.88	12.4	2.03	13.2	2.18	14.8	2.48	16.4	2.80		
20	8.37			1.35	10.0	1.62	11.6	1.91	12.4	2.06	13.2	2.22	14.8	2.57	16.4	2.99		
21	8.37			1.36	10.0	1.64	11.6	1.93	12.4	2.09	13.2	2.26	14.8	2.67	16.4	3.10		
23	8.37			1.39	10.0	1.67	11.6	2.03	12.4	2.22	13.2	2.42	14.8	2.86	16.4	3.32		
25	8.37			1.43	10.0	1.78	11.6	2.16	12.4	2.37	13.2	2.59	14.8	3.06	16.4	3.56		
27	8.37			1.52	10.0	1.89	11.6	2.31	12.4	2.53	13.2	2.77	14.8	3.27	16.4	3.81		
29	8.37			1.62	10.0	2.02	11.6	2.46	12.4	2.70	13.2	2.95	14.8	3.49	16.4	4.07		
31	8.37			1.72	10.0	2.15	11.6	2.62	12.4	2.88	13.2	3.15	14.8	3.72	16.4	4.35		
33	8.37			1.82	10.0	2.28	11.6	2.79	12.4	3.07	13.2	3.35	14.8	3.97	16.4	4.64		
35	8.37			1.93	10.0	2.42	11.6	2.97	12.4	3.26	13.2	3.57	14.8	4.23	16.2	4.82		
37	8.37			2.05	10.0	2.57	11.6	3.16	12.4	3.47	13.2	3.80	14.8	4.51	15.9	4.98		
39	8.37			2.17	10.0	2.73	11.6	3.36	12.4	3.69	13.2	4.05	14.8	4.81	15.7	5.15		
70	10.85			10	7.32	1.09	8.73	1.29	10.1	1.51	10.9	1.62	11.6	1.74	13.0	1.98	14.4	2.22
				12	7.32	1.11	8.73	1.32	10.1	1.54	10.9	1.65	11.6	1.77	13.0	2.01	14.4	2.26
		14	7.32	1.12	8.73	1.34	10.1	1.56	10.9	1.68	11.6	1.80	13.0	2.05	14.4	2.31		
		16	7.32	1.14	8.73	1.36	10.1	1.59	10.9	1.71	11.6	1.84	13.0	2.09	14.4	2.35		
		18	7.32	1.16	8.73	1.38	10.1	1.62	10.9	1.74	11.6	1.87	13.0	2.13	14.4	2.40		
		20	7.32	1.18	8.73	1.41	10.1	1.65	10.9	1.78	11.6	1.91	13.0	2.17	14.4	2.46		
		21	7.32	1.19	8.73	1.42	10.1	1.67	10.9	1.80	11.6	1.93	13.0	2.21	14.4	2.55		
		23	7.32	1.21	8.73	1.45	10.1	1.70	10.9	1.86	11.6	2.02	13.0	2.36	14.4	2.73		
		25	7.32	1.23	8.73	1.51	10.1	1.82	10.9	1.98	11.6	2.16	13.0	2.52	14.4	2.92		
		27	7.32	1.30	8.73	1.60	10.1	1.93	10.9	2.11	11.6	2.30	13.0	2.70	14.4	3.13		
		29	7.32	1.38	8.73	1.70	10.1	2.06	10.9	2.25	11.6	2.45	13.0	2.88	14.4	3.34		
		31	7.32	1.47	8.73	1.81	10.1	2.19	10.9	2.40	11.6	2.61	13.0	3.07	14.4	3.56		
		33	7.32	1.55	8.73	1.92	10.1	2.33	10.9	2.55	11.6	2.78	13.0	3.27	14.4	3.80		
		35	7.32	1.65	8.73	2.04	10.1	2.47	10.9	2.71	11.6	2.95	13.0	3.48	14.4	4.05		
		37	7.32	1.74	8.73	2.16	10.1	2.63	10.9	2.88	11.6	3.14	13.0	3.70	14.4	4.31		
		39	7.32	1.84	8.73	2.29	10.1	2.79	10.9	3.06	11.6	3.34	13.0	3.94	14.4	4.59		
		60	9.30	10	6.28	0.95	7.49	1.11	8.70	1.29	9.30	1.38	9.90	1.47	11.1	1.67	12.3	1.87
				12	6.28	0.96	7.49	1.13	8.70	1.31	9.30	1.40	9.90	1.50	11.1	1.70	12.3	1.90
14	6.28			0.98	7.49	1.15	8.70	1.33	9.30	1.43	9.90	1.52	11.1	1.73	12.3	1.94		
16	6.28			0.99	7.49	1.17	8.70	1.35	9.30	1.45	9.90	1.55	11.1	1.76	12.3	1.97		
18	6.28			1.01	7.49	1.19	8.70	1.38	9.30	1.48	9.90	1.58	11.1	1.79	12.3	2.01		
20	6.28			1.02	7.49	1.21	8.70	1.40	9.30	1.51	9.90	1.61	11.1	1.83	12.3	2.05		
21	6.28			1.03	7.49	1.22	8.70	1.42	9.30	1.52	9.90	1.63	11.1	1.84	12.3	2.07		
23	6.28			1.05	7.49	1.24	8.70	1.44	9.30	1.55	9.90	1.66	11.1	1.92	12.3	2.20		
25	6.28			1.06	7.49	1.26	8.70	1.50	9.30	1.63	9.90	1.76	11.1	2.05	12.3	2.35		
27	6.28			1.10	7.49	1.34	8.70	1.59	9.30	1.73	9.90	1.88	11.1	2.18	12.3	2.51		
29	6.28			1.17	7.49	1.42	8.70	1.69	9.30	1.84	9.90	2.00	11.1	2.32	12.3	2.68		
31	6.28			1.24	7.49	1.50	8.70	1.80	9.30	1.96	9.90	2.12	11.1	2.47	12.3	2.85		
33	6.28			1.31	7.49	1.60	8.70	1.91	9.30	2.08	9.90	2.26	11.1	2.63	12.3	3.04		
35	6.28			1.38	7.49	1.69	8.70	2.03	9.30	2.21	9.90	2.40	11.1	2.80	12.3	3.23		
37	6.28			1.46	7.49	1.79	8.70	2.15	9.30	2.34	9.90	2.55	11.1	2.98	12.3	3.44		
39	6.28			1.55	7.49	1.89	8.70	2.28	9.30	2.49	9.90	2.70	11.1	3.16	12.3	3.66		
50	7.75			10	5.23	0.82	6.24	0.94	7.25	1.08	7.75	1.15	8.25	1.22	9.26	1.37	10.3	1.53
				12	5.23	0.83	6.24	0.96	7.25	1.10	7.75	1.17	8.25	1.24	9.26	1.40	10.3	1.56
		14	5.23	0.84	6.24	0.97	7.25	1.11	7.75	1.19	8.25	1.26	9.26	1.42	10.3	1.58		
		16	5.23	0.85	6.24	0.99	7.25	1.13	7.75	1.21	8.25	1.28	9.26	1.45	10.3	1.61		
		18	5.23	0.86	6.24	1.00	7.25	1.15	7.75	1.23	8.25	1.31	9.26	1.47	10.3	1.64		
		20	5.23	0.87	6.24	1.02	7.25	1.17	7.75	1.25	8.25	1.33	9.26	1.50	10.3	1.67		
		21	5.23	0.88	6.24	1.02	7.25	1.18	7.75	1.26	8.25	1.34	9.26	1.51	10.3	1.69		
		23	5.23	0.89	6.24	1.04	7.25	1.20	7.75	1.28	8.25	1.37	9.26	1.54	10.3	1.73		
		25	5.23	0.91	6.24	1.06	7.25	1.22	7.75	1.31	8.25	1.41	9.26	1.62	10.3	1.84		
		27	5.23	0.92	6.24	1.10	7.25	1.29	7.75	1.39	8.25	1.50	9.26	1.72	10.3	1.97		
		29	5.23	0.97	6.24	1.16	7.25	1.37	7.75	1.48	8.25	1.59	9.26	1.83	10.3	2.09		
		31	5.23	1.03	6.24	1.23	7.25	1.45	7.75	1.57	8.25	1.69	9.26	1.95	10.3	2.23		
		33	5.23	1.09	6.24	1.30	7.25	1.54	7.75	1.66	8.25	1.79	9.26	2.07	10.3	2.37		
		35	5.23	1.15	6.24	1.38	7.25	1.63	7.75	1.76	8.25	1.90	9.26	2.20	10.3	2.52		
		37	5.23	1.21	6.24	1.45	7.25	1.72	7.75	1.86	8.25	2.01	9.26	2.33	10.3	2.67		
		39	5.23	1.27	6.24	1.53	7.25	1.82	7.75	1.97	8.25	2.13	9.26	2.47	10.3	2.84		

4TW30372-1

10

3

3 Capacity tables

3 - 2 Heating capacity tables

RXYSQ4PAV1		TC: Total capacity (kW); PI: Power Input (kW) (Compressor + Outdoor fan motor)													
Combination (%)	Capacity index (kW)	Outdoor air temp.		Indoor air temp. (°CWB)											
				16.0		18.0		20.0		21.0		22.0		24.0	
		°CDB	°CWB	TC	PI	TC	PI	TC	PI	TC	PI	TC	PI	TC	PI
130	16.25	-19.8	-20	10.2	3.26	10.2	3.39	10.1	3.52	10.1	3.59	10.1	3.65	10.1	3.78
		-18.8	-19	10.5	3.33	10.5	3.46	10.4	3.59	10.4	3.65	10.4	3.71	10.4	3.84
		-16.7	-17	11.1	3.46	11.1	3.58	11.0	3.70	11.0	3.76	11.0	3.82	11.0	3.94
		-14.7	-15	11.7	3.58	11.7	3.69	11.7	3.81	11.6	3.87	11.6	3.92	11.6	4.04
		-12.6	-13	12.3	3.69	12.3	3.79	12.3	3.90	12.3	3.96	12.2	4.01	12.2	4.12
		-10.5	-11	12.9	3.78	12.9	3.89	12.9	3.99	12.9	4.04	12.9	4.09	12.8	4.19
		-9.5	-10	13.2	3.83	13.2	3.93	13.2	4.03	13.2	4.08	13.2	4.13	13.1	4.23
		-8.5	-9.1	13.5	3.87	13.5	3.97	13.5	4.06	13.4	4.11	13.4	4.16	13.4	4.26
		-7.0	-7.6	14.0	3.93	13.9	4.02	13.9	4.12	13.9	4.17	13.9	4.21	13.9	4.31
		-5.0	-5.6	14.6	4.00	14.6	4.09	14.5	4.19	14.5	4.23	14.5	4.28	14.2	4.22
		-3.0	-3.7	15.2	4.07	15.1	4.16	15.1	4.24	15.1	4.29	15.1	4.33	14.2	4.00
		0.0	-0.7	16.1	4.17	16.1	4.25	16.0	4.33	15.7	4.25	15.2	4.06	14.2	3.71
		3.0	2.2	17.0	4.25	16.9	4.33	16.3	4.13	15.7	3.96	15.2	3.79	14.2	3.46
		5.0	4.1	17.6	4.30	17.3	4.28	16.3	3.95	15.7	3.79	15.2	3.63	14.2	3.32
		7.0	6	18.1	4.34	17.3	4.10	16.3	3.79	15.7	3.63	15.2	3.48	14.2	3.19
		9.0	7.9	18.3	4.25	17.3	3.94	16.3	3.64	15.7	3.49	15.2	3.35	14.2	3.07
		11.0	9.8	18.3	4.08	17.3	3.79	16.3	3.50	15.7	3.36	15.2	3.22	14.2	2.95
13.0	11.8	18.3	3.92	17.3	3.64	16.3	3.36	15.7	3.23	15.2	3.10	14.2	2.84		
15.0	13.7	18.3	3.78	17.3	3.51	16.3	3.25	15.7	3.12	15.2	2.99	14.2	2.75		
120	15.00	-19.8	-20	10.1	3.44	10.1	3.56	10.1	3.68	10.1	3.74	10.1	3.80	10.0	3.92
		-18.8	-19	10.5	3.50	10.4	3.62	10.4	3.74	10.4	3.80	10.4	3.86	10.3	3.97
		-16.7	-17	11.1	3.62	11.0	3.74	11.0	3.85	11.0	3.90	11.0	3.96	11.0	4.07
		-14.7	-15	11.7	3.73	11.6	3.84	11.6	3.94	11.6	4.00	11.6	4.05	11.6	4.16
		-12.6	-13	12.3	3.83	12.3	3.93	12.2	4.03	12.2	4.08	12.2	4.13	12.2	4.23
		-10.5	-11	12.9	3.92	12.9	4.02	12.8	4.11	12.8	4.16	12.8	4.21	12.8	4.30
		-9.5	-10	13.2	3.96	13.2	4.06	13.2	4.15	13.1	4.20	13.1	4.24	13.1	4.32
		-8.5	-9.1	13.5	4.00	13.5	4.09	13.4	4.18	13.4	4.23	13.4	4.27	13.1	4.20
		-7.0	-7.6	13.9	4.06	13.9	4.14	13.9	4.23	13.9	4.28	13.9	4.32	13.1	4.02
		-5.0	-5.6	14.5	4.13	14.5	4.21	14.5	4.29	14.5	4.34	14.0	4.17	13.1	3.80
		-3.0	-3.7	15.1	4.19	15.1	4.27	15.0	4.31	14.5	4.14	14.0	3.96	13.1	3.62
		0.0	-0.7	16.0	4.28	16.0	4.33	15.0	3.99	14.5	3.83	14.0	3.67	13.1	3.36
		3.0	2.2	16.9	4.35	16.0	4.03	15.0	3.72	14.5	3.57	14.0	3.43	13.1	3.14
		5.0	4.1	16.9	4.16	16.0	3.86	15.0	3.57	14.5	3.42	14.0	3.28	13.1	3.01
		7.0	6	16.9	3.99	16.0	3.70	15.0	3.42	14.5	3.29	14.0	3.15	13.1	2.89
		9.0	7.9	16.9	3.83	16.0	3.56	15.0	3.29	14.5	3.16	14.0	3.03	13.1	2.78
		11.0	9.8	16.9	3.68	16.0	3.42	15.0	3.17	14.5	3.04	14.0	2.92	13.1	2.68
13.0	11.8	16.9	3.54	16.0	3.29	15.0	3.05	14.5	2.93	14.0	2.81	13.1	2.58		
15.0	13.7	16.9	3.42	16.0	3.18	15.0	2.94	14.5	2.83	14.0	2.72	13.1	2.50		
110	13.75	-19.8	-20	10.1	3.61	10.1	3.73	10.1	3.84	10.0	3.89	10.0	3.95	10.0	4.06
		-18.8	-19	10.4	3.68	10.4	3.78	10.4	3.89	10.4	3.95	10.3	4.00	10.3	4.11
		-16.7	-17	11.0	3.79	11.0	3.89	11.0	3.99	11.0	4.04	11.0	4.09	10.9	4.20
		-14.7	-15	11.6	3.89	11.6	3.98	11.6	4.08	11.6	4.13	11.6	4.18	11.5	4.27
		-12.6	-13	12.2	3.98	12.2	4.07	12.2	4.16	12.2	4.21	12.2	4.25	12.0	4.25
		-10.5	-11	12.9	4.06	12.8	4.15	12.8	4.24	12.8	4.28	12.8	4.32	12.0	3.98
		-9.5	-10	13.2	4.10	13.1	4.18	13.1	4.27	13.1	4.31	12.9	4.23	12.0	3.86
		-8.5	-9.1	13.4	4.13	13.4	4.22	13.4	4.30	13.3	4.30	12.9	4.12	12.0	3.76
		-7.0	-7.6	13.9	4.18	13.9	4.27	13.8	4.30	13.3	4.12	12.9	3.94	12.0	3.60
		-5.0	-5.6	14.5	4.25	14.5	4.33	13.8	4.06	13.3	3.89	12.9	3.73	12.0	3.41
		-3.0	-3.7	15.1	4.31	14.6	4.18	13.8	3.86	13.3	3.70	12.9	3.54	12.0	3.24
		0.0	-0.7	15.5	4.17	14.6	3.87	13.8	3.57	13.3	3.43	12.9	3.29	12.0	3.01
		3.0	2.2	15.5	3.89	14.6	3.61	13.8	3.34	13.3	3.21	12.9	3.08	12.0	2.82
		5.0	4.1	15.5	3.72	14.6	3.46	13.8	3.20	13.3	3.08	12.9	2.95	12.0	2.71
		7.0	6	15.5	3.57	14.6	3.32	13.8	3.07	13.3	2.95	12.9	2.84	12.0	2.61
		9.0	7.9	15.5	3.43	14.6	3.19	13.8	2.96	13.3	2.84	12.9	2.73	12.0	2.51
		11.0	9.8	15.5	3.30	14.6	3.07	13.8	2.85	13.3	2.74	12.9	2.63	12.0	2.42
13.0	11.8	15.5	3.18	14.6	2.96	13.8	2.74	13.3	2.64	12.9	2.54	12.0	2.34		
15.0	13.7	15.5	3.07	14.6	2.86	13.8	2.65	13.3	2.55	12.9	2.45	12.0	2.26		
100	12.50	-19.8	-20	10.1	3.79	10.0	3.89	10.0	3.99	10.0	4.05	10.0	4.10	10.0	4.20
		-18.8	-19	10.4	3.85	10.4	3.95	10.3	4.04	10.3	4.09	10.3	4.14	10.3	4.24
		-16.7	-17	11.0	3.95	11.0	4.04	10.9	4.14	10.9	4.18	10.9	4.23	10.9	4.32
		-14.7	-15	11.6	4.04	11.6	4.13	11.6	4.22	11.5	4.26	11.5	4.31	10.9	4.02
		-12.6	-13	12.2	4.13	12.2	4.21	12.2	4.29	12.1	4.30	11.7	4.12	10.9	3.76
		-10.5	-11	12.8	4.20	12.8	4.28	12.5	4.21	12.1	4.03	11.7	3.86	10.9	3.53
		-9.5	-10	13.1	4.24	13.1	4.31	12.5	4.08	12.1	3.91	11.7	3.75	10.9	3.42
		-8.5	-9.1	13.4	4.27	13.3	4.30	12.5	3.97	12.1	3.81	11.7	3.65	10.9	3.33
		-7.0	-7.6	13.9	4.31	13.3	4.11	12.5	3.80	12.1	3.64	11.7	3.49	10.9	3.20
		-5.0	-5.6	14.1	4.19	13.3	3.89	12.5	3.59	12.1	3.45	11.7	3.31	10.9	3.03
		-3.0	-3.7	14.1	3.98	13.3	3.70	12.5	3.42	12.1	3.28	11.7	3.15	10.9	2.89
		0.0	-0.7	14.1	3.69	13.3	3.43	12.5	3.17	12.1	3.05	11.7	2.93	10.9	2.69
		3.0	2.2	14.1	3.45	13.3	3.21	12.5	2.97	12.1	2.85	11.7	2.74	10.9	2.52
		5.0	4.1	14.1	3.30	13.3	3.07	12.5	2.85	12.1	2.74	11.7	2.63	10.9	2.42
		7.0	6	14.1	3.17	13.3	2.95	12.5	2.74	12.1	2.64	11.7	2.53	10.9	2.33
		9.0	7.9	14.1	3.05	13.3	2.84	12.5	2.64	12.1	2.54	11.7	2.44	10.9	2.25
		11.0	9.8	14.1	2.94	13.3	2.74	12.5	2.54	12.1	2.45	11.7	2.35	10.9	2.17
13.0	11.8	14.1	2.83	13.3	2.64	12.5	2.45	12.1	2.36	11.7	2.27	10.9	2.09		
15.0	13.7	14.1	2.73	13.3	2.55	12.5	2.37	12.1	2.28	11.7	2.20	10.9	2.03		

4TW30372-2

NOTE

1 The above table shows the average value of conditions which may occur.

3 Capacity tables

3 - 2 Heating capacity tables

RXYSQ4PAV1				Indoor air temp. (°CWB)											
Combination (%)	Capacity index (kW)	Outdoor air temp.		16.0		18.0		20.0		21.0		22.0		24.0	
		°CDB	°CWB	TC	PI	TC	PI	TC	PI	TC	PI	TC	PI	TC	PI
				kW	kW	kW	kW	kW	kW	kW	kW	kW	kW	kW	kW
90	11.25	-19.8	-20	10.0	3.97	10.0	4.06	10.0	4.15	10.0	4.20	10.0	4.24	9.80	4.23
		-18.8	-19	10.3	4.02	10.3	4.11	10.3	4.20	10.3	4.24	10.3	4.29	9.80	4.07
		-16.7	-17	10.9	4.11	10.9	4.20	10.9	4.28	10.9	4.32	10.5	4.13	9.80	3.77
		-14.7	-15	11.6	4.20	11.5	4.28	11.3	4.19	10.9	4.02	10.5	3.85	9.80	3.51
		-12.6	-13	12.2	4.27	12.0	4.24	11.3	3.92	10.9	3.76	10.5	3.60	9.80	3.29
		-10.5	-11	12.7	4.29	12.0	3.98	11.3	3.67	10.9	3.53	10.5	3.38	9.80	3.10
		-9.5	-10	12.7	4.16	12.0	3.86	11.3	3.56	10.9	3.42	10.5	3.28	9.80	3.01
		-8.5	-9.1	12.7	4.05	12.0	3.76	11.3	3.47	10.9	3.33	10.5	3.20	9.80	2.93
		-7.0	-7.6	12.7	3.87	12.0	3.60	11.3	3.33	10.9	3.19	10.5	3.07	9.80	2.81
		-5.0	-5.6	12.7	3.66	12.0	3.40	11.3	3.15	10.9	3.03	10.5	2.91	9.80	2.67
		-3.0	-3.7	12.7	3.49	12.0	3.24	11.3	3.00	10.9	2.89	10.5	2.77	9.80	2.55
		0.0	-0.7	12.7	3.24	12.0	3.01	11.3	2.79	10.9	2.69	10.5	2.58	9.80	2.37
		3.0	2.2	12.7	3.03	12.0	2.82	11.3	2.62	10.9	2.52	10.5	2.42	9.80	2.23
		5.0	4.1	12.7	2.90	12.0	2.71	11.3	2.51	10.9	2.42	10.5	2.33	9.80	2.15
		7.0	6	12.7	2.79	12.0	2.60	11.3	2.42	10.9	2.33	10.5	2.24	9.80	2.07
		9.0	7.9	12.7	2.69	12.0	2.51	11.3	2.33	10.9	2.25	10.5	2.16	9.80	2.00
		11.0	9.8	12.7	2.59	12.0	2.42	11.3	2.25	10.9	2.17	10.5	2.09	9.80	1.93
13.0	11.8	12.7	2.50	12.0	2.33	11.3	2.17	10.9	2.09	10.5	2.02	9.80	1.86		
15.0	13.7	12.7	2.41	12.0	2.26	11.3	2.10	10.9	2.03	10.5	1.95	9.80	1.81		
80	10.00	-19.8	-20	10.0	4.15	10.0	4.23	10.0	4.31	9.68	4.16	9.36	3.98	8.71	3.64
		-18.8	-19	10.3	4.19	10.3	4.27	10.0	4.17	9.68	4.00	9.36	3.83	8.71	3.50
		-16.7	-17	10.9	4.28	10.6	4.19	10.0	3.87	9.68	3.71	9.36	3.55	8.71	3.25
		-14.7	-15	11.3	4.21	10.6	3.90	10.0	3.60	9.68	3.46	9.36	3.32	8.71	3.04
		-12.6	-13	11.3	3.93	10.6	3.65	10.0	3.37	9.68	3.24	9.36	3.11	8.71	2.85
		-10.5	-11	11.3	3.69	10.6	3.43	10.0	3.17	9.68	3.05	9.36	2.92	8.71	2.68
		-9.5	-10	11.3	3.58	10.6	3.33	10.0	3.08	9.68	2.96	9.36	2.84	8.71	2.61
		-8.5	-9.1	11.3	3.49	10.6	3.24	10.0	3.00	9.68	2.88	9.36	2.77	8.71	2.55
		-7.0	-7.6	11.3	3.34	10.6	3.11	10.0	2.88	9.68	2.77	9.36	2.66	8.71	2.45
		-5.0	-5.6	11.3	3.16	10.6	2.94	10.0	2.73	9.68	2.63	9.36	2.53	8.71	2.32
		-3.0	-3.7	11.3	3.01	10.6	2.81	10.0	2.61	9.68	2.51	9.36	2.41	8.71	2.22
		0.0	-0.7	11.3	2.80	10.6	2.61	10.0	2.43	9.68	2.34	9.36	2.25	8.71	2.08
		3.0	2.2	11.3	2.63	10.6	2.45	10.0	2.28	9.68	2.20	9.36	2.12	8.71	1.95
		5.0	4.1	11.3	2.52	10.6	2.36	10.0	2.19	9.68	2.11	9.36	2.04	8.71	1.88
		7.0	6	11.3	2.43	10.6	2.27	10.0	2.11	9.68	2.04	9.36	1.96	8.71	1.81
		9.0	7.9	11.3	2.34	10.6	2.19	10.0	2.04	9.68	1.97	9.36	1.89	8.71	1.75
		11.0	9.8	11.3	2.26	10.6	2.11	10.0	1.97	9.68	1.90	9.36	1.83	8.71	1.70
13.0	11.8	11.3	2.18	10.6	2.04	10.0	1.90	9.68	1.84	9.36	1.77	8.71	1.64		
15.0	13.7	11.3	2.11	10.6	1.98	10.0	1.84	9.68	1.78	9.36	1.72	8.71	1.59		
70	8.75	-19.8	-20	9.87	4.27	9.31	3.96	8.75	3.66	8.47	3.51	8.19	3.36	7.63	3.08
		-18.8	-19	9.87	4.10	9.31	3.81	8.75	3.52	8.47	3.38	8.19	3.24	7.63	2.97
		-16.7	-17	9.87	3.80	9.31	3.53	8.75	3.27	8.47	3.14	8.19	3.01	7.63	2.76
		-14.7	-15	9.87	3.55	9.31	3.30	8.75	3.05	8.47	2.93	8.19	2.82	7.63	2.59
		-12.6	-13	9.87	3.32	9.31	3.09	8.75	2.86	8.47	2.75	8.19	2.64	7.63	2.43
		-10.5	-11	9.87	3.12	9.31	2.91	8.75	2.70	8.47	2.59	8.19	2.49	7.63	2.30
		-9.5	-10	9.87	3.03	9.31	2.82	8.75	2.62	8.47	2.52	8.19	2.42	7.63	2.23
		-8.5	-9.1	9.87	2.96	9.31	2.75	8.75	2.56	8.47	2.46	8.19	2.37	7.63	2.18
		-7.0	-7.6	9.87	2.84	9.31	2.64	8.75	2.46	8.47	2.37	8.19	2.27	7.63	2.10
		-5.0	-5.6	9.87	2.69	9.31	2.51	8.75	2.34	8.47	2.25	8.19	2.16	7.63	2.00
		-3.0	-3.7	9.87	2.57	9.31	2.40	8.75	2.23	8.47	2.15	8.19	2.07	7.63	1.91
		0.0	-0.7	9.87	2.39	9.31	2.24	8.75	2.08	8.47	2.01	8.19	1.94	7.63	1.79
		3.0	2.2	9.87	2.25	9.31	2.10	8.75	1.96	8.47	1.89	8.19	1.82	7.63	1.69
		5.0	4.1	9.87	2.16	9.31	2.02	8.75	1.89	8.47	1.82	8.19	1.76	7.63	1.63
		7.0	6	9.87	2.08	9.31	1.95	8.75	1.82	8.47	1.76	8.19	1.70	7.63	1.57
		9.0	7.9	9.87	2.01	9.31	1.88	8.75	1.76	8.47	1.70	8.19	1.64	7.63	1.52
		11.0	9.8	9.87	1.94	9.31	1.82	8.75	1.70	8.47	1.65	8.19	1.59	7.63	1.47
13.0	11.8	9.87	1.88	9.31	1.76	8.75	1.65	8.47	1.59	8.19	1.54	7.63	1.43		
15.0	13.7	9.87	1.82	9.31	1.71	8.75	1.60	8.47	1.54	8.19	1.49	7.63	1.39		
60	7.50	-19.8	-20	8.46	3.51	7.98	3.26	7.50	3.02	7.26	2.90	7.02	2.78	6.54	2.56
		-18.8	-19	8.46	3.37	7.98	3.14	7.50	2.91	7.26	2.79	7.02	2.68	6.54	2.47
		-16.7	-17	8.46	3.14	7.98	2.92	7.50	2.71	7.26	2.61	7.02	2.50	6.54	2.30
		-14.7	-15	8.46	2.93	7.98	2.73	7.50	2.54	7.26	2.44	7.02	2.35	6.54	2.16
		-12.6	-13	8.46	2.75	7.98	2.57	7.50	2.39	7.26	2.30	7.02	2.21	6.54	2.04
		-10.5	-11	8.46	2.59	7.98	2.42	7.50	2.25	7.26	2.17	7.02	2.09	6.54	1.93
		-9.5	-10	8.46	2.52	7.98	2.35	7.50	2.19	7.26	2.11	7.02	2.03	6.54	1.88
		-8.5	-9.1	8.46	2.46	7.98	2.30	7.50	2.14	7.26	2.06	7.02	1.99	6.54	1.84
		-7.0	-7.6	8.46	2.36	7.98	2.21	7.50	2.06	7.26	1.98	7.02	1.91	6.54	1.77
		-5.0	-5.6	8.46	2.25	7.98	2.10	7.50	1.96	7.26	1.89	7.02	1.82	6.54	1.69
		-3.0	-3.7	8.46	2.15	7.98	2.01	7.50	1.88	7.26	1.81	7.02	1.75	6.54	1.62
		0.0	-0.7	8.46	2.01	7.98	1.88	7.50	1.76	7.26	1.70	7.02	1.64	6.54	1.52
		3.0	2.2	8.46	1.89	7.98	1.77	7.50	1.66	7.26	1.60	7.02	1.55	6.54	1.44
		5.0	4.1	8.46	1.82	7.98	1.71	7.50	1.60	7.26	1.55	7.02	1.49	6.54	1.39
		7.0	6	8.46	1.76	7.98	1.65	7.50	1.55	7.26	1.49	7.02	1.44	6.54	1.34
		9.0	7.9	8.46	1.70	7.98	1.60	7.50	1.50	7.26	1.45	7.02	1.40	6.54	1.30
		11.0	9.8	8.46	1.64	7.98	1.55	7.50	1.45	7.26	1.40	7.02	1.35	6.54	1.26
13.0	11.8	8.46	1.59	7.98	1.50	7.50	1.40	7.26	1.36	7.02	1.31	6.54	1.22		
15.0	13.7	8.46	1.54	7.98	1.45	7.50	1.36	7.26	1.32	7.02	1.28	6.54	1.19		
50	6.25	-19.8	-20	7.05	2.80	6.65	2.61	6.25	2.43	6.05	2.34	5.85	2.25	5.45	2.07
		-18.8	-19	7.05	2.70	6.65	2.52	6.25	2.34	6.05	2.26	5.85	2.17	5.45	2.00
		-16.7	-17	7.05	2.52	6.65	2.35	6.25	2.19	6.05	2.11	5.85	2.03	5.45	1.88
		-14.7	-15	7.05	2.36	6.65	2.21	6.25	2.06	6.05	1.98	5.85	1.91	5.45	1.77
		-12.6	-13	7.05	2.22	6.65	2.08	6.25	1.94	6					

3 Capacity tables

3 - 2 Heating capacity tables

RXYSQ5PAV1		TC: Total capacity (kW); PI: Power Input (kW) (Compressor + Outdoor fan motor)													
Combination (%)	Capacity index (kW)	Outdoor air temp.		Indoor air temp. (°CWB)											
				16.0		18.0		20.0		21.0		22.0		24.0	
		°CDB	°CWB	TC	PI	TC	PI	TC	PI	TC	PI	TC	PI	TC	PI
130	20.80	-19.8	-20.0	11.1	3.10	11.0	3.29	11.0	3.47	11.0	3.57	11.0	3.66	10.9	3.85
		-18.8	-19.0	11.4	3.20	11.4	3.38	11.3	3.56	11.3	3.65	11.3	3.74	11.3	3.92
		-16.7	-17.0	12.1	3.39	12.0	3.56	12.0	3.73	12.0	3.81	11.9	3.90	11.9	4.07
		-14.7	-15.0	12.7	3.55	12.7	3.72	12.6	3.88	12.6	3.96	12.6	4.04	12.6	4.20
		-12.6	-13.0	13.4	3.70	13.3	3.86	13.3	4.01	13.3	4.08	13.3	4.16	13.2	4.31
		-10.5	-11.0	14.0	3.84	14.0	3.98	14.0	4.13	13.9	4.20	13.9	4.27	13.9	4.42
		-9.5	-10.0	14.4	3.90	14.3	4.04	14.3	4.18	14.3	4.25	14.3	4.33	14.2	4.47
		-8.5	-9.1	14.7	3.95	14.6	4.09	14.6	4.23	14.6	4.30	14.5	4.37	14.5	4.51
		-7.0	-7.6	15.2	4.04	15.1	4.17	15.1	4.31	15.1	4.37	15.0	4.44	15.0	4.58
		-5.0	-5.6	15.8	4.15	15.8	4.27	15.7	4.40	15.7	4.47	15.7	4.53	15.7	4.66
		-3.0	-3.7	16.4	4.24	16.4	4.36	16.4	4.48	16.3	4.55	16.3	4.61	16.3	4.73
		0.0	-0.7	17.4	4.37	17.4	4.49	17.4	4.60	17.3	4.66	17.3	4.72	17.3	4.83
		3.0	2.2	18.4	4.49	18.3	4.60	18.3	4.71	18.3	4.76	18.3	4.82	18.1	4.88
		5.0	4.1	19.0	4.55	19.0	4.66	18.9	4.77	18.9	4.82	18.9	4.87	18.1	4.68
		7.0	6.0	19.6	4.62	19.6	4.72	19.6	4.83	19.5	4.88	19.5	4.91	18.1	4.49
		9.0	7.9	20.3	4.68	20.2	4.78	20.2	4.88	20.1	4.92	19.5	4.72	18.1	4.32
		11.0	9.8	20.9	4.74	20.8	4.83	20.8	4.93	20.1	4.73	19.5	4.54	18.1	4.16
13.0	11.8	21.5	4.80	21.5	4.89	20.8	4.74	20.1	4.55	19.5	4.37	18.1	4.01		
15.0	13.7	22.2	4.85	22.1	4.94	20.8	4.57	20.1	4.39	19.5	4.22	18.1	3.87		
120	19.20	-19.8	-20.0	11.0	3.35	11.0	3.53	11.0	3.70	10.9	3.78	10.9	3.87	10.9	4.04
		-18.8	-19.0	11.4	3.45	11.3	3.61	11.3	3.78	11.3	3.86	11.2	3.95	11.2	4.11
		-16.7	-17.0	12.0	3.62	12.0	3.78	11.9	3.93	11.9	4.01	11.9	4.09	11.9	4.25
		-14.7	-15.0	12.7	3.77	12.6	3.92	12.6	4.07	12.6	4.14	12.6	4.22	12.5	4.36
		-12.6	-13.0	13.3	3.91	13.3	4.05	13.3	4.19	13.2	4.26	13.2	4.33	13.2	4.47
		-10.5	-11.0	14.0	4.03	14.0	4.17	13.9	4.30	13.9	4.37	13.9	4.44	13.8	4.57
		-9.5	-10.0	14.3	4.09	14.3	4.22	14.2	4.35	14.2	4.42	14.2	4.48	14.2	4.61
		-8.5	-9.1	14.6	4.14	14.6	4.27	14.5	4.40	14.5	4.46	14.5	4.53	14.5	4.65
		-7.0	-7.6	15.1	4.22	15.1	4.34	15.0	4.47	15.0	4.53	15.0	4.59	15.0	4.72
		-5.0	-5.6	15.8	4.32	15.7	4.44	15.7	4.56	15.7	4.61	15.7	4.67	15.6	4.79
		-3.0	-3.7	16.4	4.40	16.4	4.52	16.3	4.63	16.3	4.69	16.3	4.75	16.3	4.86
		0.0	-0.7	17.4	4.53	17.3	4.63	17.3	4.74	17.3	4.80	17.3	4.85	16.7	4.73
		3.0	2.2	18.3	4.63	18.3	4.74	18.3	4.84	18.2	4.89	18.0	4.83	16.7	4.42
		5.0	4.1	19.0	4.70	18.9	4.80	18.9	4.89	18.6	4.82	18.0	4.63	16.7	4.24
		7.0	6.0	19.6	4.76	19.5	4.85	19.2	4.82	18.6	4.63	18.0	4.44	16.7	4.07
		9.0	7.9	20.2	4.82	20.2	4.91	19.2	4.64	18.6	4.45	18.0	4.27	16.7	3.92
		11.0	9.8	20.8	4.87	20.4	4.82	19.2	4.46	18.6	4.29	18.0	4.12	16.7	3.78
13.0	11.8	21.5	4.92	20.4	4.64	19.2	4.29	18.6	4.13	18.0	3.96	16.7	3.64		
15.0	13.7	21.7	4.81	20.4	4.47	19.2	4.15	18.6	3.99	18.0	3.83	16.7	3.52		
110	17.60	-19.8	-20.0	11.0	3.60	10.9	3.76	10.9	3.92	10.9	4.00	10.9	4.08	10.8	4.23
		-18.8	-19.0	11.3	3.69	11.3	3.84	11.2	4.00	11.2	4.07	11.2	4.15	11.2	4.30
		-16.7	-17.0	12.0	3.85	11.9	3.99	11.9	4.14	11.9	4.21	11.9	4.28	11.8	4.42
		-14.7	-15.0	12.6	3.99	12.6	4.12	12.6	4.26	12.5	4.33	12.5	4.40	12.5	4.53
		-12.6	-13.0	13.3	4.12	13.2	4.24	13.2	4.37	13.2	4.44	13.2	4.50	13.2	4.63
		-10.5	-11.0	13.9	4.23	13.9	4.35	13.9	4.48	13.9	4.54	13.8	4.60	13.8	4.72
		-9.5	-10.0	14.3	4.28	14.2	4.40	14.2	4.52	14.2	4.58	14.2	4.64	14.1	4.76
		-8.5	-9.1	14.6	4.33	14.5	4.45	14.5	4.56	14.5	4.62	14.5	4.68	14.4	4.80
		-7.0	-7.6	15.1	4.40	15.0	4.50	15.0	4.63	15.0	4.69	15.0	4.74	14.9	4.86
		-5.0	-5.6	15.7	4.49	15.7	4.62	15.7	4.71	15.6	4.76	15.6	4.82	15.3	4.80
		-3.0	-3.7	16.3	4.57	16.3	4.68	16.3	4.78	16.3	4.83	16.2	4.88	15.3	4.57
		0.0	-0.7	17.3	4.68	17.3	4.78	17.3	4.88	17.0	4.83	16.5	4.63	15.3	4.25
		3.0	2.2	18.3	4.78	18.2	4.88	17.6	4.70	17.0	4.52	16.5	4.33	15.3	3.98
		5.0	4.1	18.9	4.84	18.7	4.87	17.6	4.51	17.0	4.33	16.5	4.16	15.3	3.82
		7.0	6.0	19.5	4.90	18.7	4.68	17.6	4.33	17.0	4.16	16.5	4.00	15.3	3.67
		9.0	7.9	19.9	4.84	18.7	4.50	17.6	4.17	17.0	4.01	16.5	3.85	15.3	3.54
		11.0	9.8	19.9	4.65	18.7	4.33	17.6	4.01	17.0	3.86	16.5	3.71	15.3	3.41
13.0	11.8	19.9	4.48	18.7	4.17	17.6	3.87	17.0	3.72	16.5	3.57	15.3	3.29		
15.0	13.7	19.9	4.32	18.7	4.02	17.6	3.74	17.0	3.59	16.5	3.45	15.3	3.18		
100	16.00	-19.8	-20.0	10.9	3.86	10.9	4.00	10.9	4.14	10.9	4.21	10.8	4.28	10.8	4.43
		-18.8	-19.0	11.3	3.93	11.2	4.07	11.2	4.21	11.2	4.28	11.2	4.35	11.1	4.49
		-16.7	-17.0	11.9	4.08	11.9	4.21	11.9	4.34	11.8	4.40	11.8	4.47	11.8	4.60
		-14.7	-15.0	12.6	4.21	12.5	4.33	12.5	4.45	12.5	4.51	12.5	4.58	12.5	4.70
		-12.6	-13.0	13.2	4.32	13.2	4.44	13.2	4.56	13.2	4.61	13.1	4.67	13.1	4.79
		-10.5	-11.0	13.9	4.43	13.9	4.54	13.8	4.65	13.8	4.70	13.8	4.76	13.8	4.87
		-9.5	-10.0	14.2	4.47	14.2	4.58	14.2	4.69	14.1	4.75	14.1	4.80	13.9	4.82
		-8.5	-9.1	14.5	4.52	14.5	4.62	14.5	4.73	14.4	4.78	14.4	4.84	13.9	4.70
		-7.0	-7.6	15.0	4.58	15.0	4.69	14.9	4.79	14.9	4.84	14.9	4.89	13.9	4.50
		-5.0	-5.6	15.7	4.67	15.6	4.76	15.6	4.86	15.5	4.86	15.0	4.66	13.9	4.27
		-3.0	-3.7	16.3	4.74	16.3	4.83	16.0	4.82	15.5	4.62	15.0	4.44	13.9	4.07
		0.0	-0.7	17.3	4.84	17.0	4.83	16.0	4.47	15.5	4.30	15.0	4.12	13.9	3.79
		3.0	2.2	18.1	4.86	17.0	4.52	16.0	4.18	15.5	4.02	15.0	3.86	13.9	3.55
		5.0	4.1	18.1	4.65	17.0	4.33	16.0	4.02	15.5	3.86	15.0	3.71	13.9	3.41
		7.0	6.0	18.1	4.47	17.0	4.16	16.0	3.86	15.5	3.71	15.0	3.57	13.9	3.28
		9.0	7.9	18.1	4.30	17.0	4.00	16.0	3.72	15.5	3.58	15.0	3.44	13.9	3.17
		11.0	9.8	18.1	4.14	17.0	3.86	16.0	3.58	15.5	3.45	15.0	3.32	13.9	3.06
13.0	11.8	18.1	3.99	17.0	3.72	16.0	3.45	15.5	3.33	15.0	3.20	13.9	2.95		
15.0	13.7	18.1	3.85	17.0	3.59	16.0	3.34	15.5	3.22	15.0	3.10	13.9	2.86		

4TW30372-2

NOTE

1 The above table shows the average value of conditions which may occur.

3 Capacity tables

3 - 2 Heating capacity tables

RXYSQ5PAV1				Indoor air temp. (°CWB)											
Combination (%)	Capacity index (kW)	Outdoor air temp.		16.0		18.0		20.0		21.0		22.0		24.0	
		°CDB	°CWB	TC	PI	TC	PI	TC	PI	TC	PI	TC	PI	TC	PI
				kW	kW	kW	kW	kW	kW	kW	kW	kW	kW	kW	kW
90	14.40	-19.8	-20.0	10.9	4.11	10.8	4.23	10.8	4.36	10.8	4.43	10.8	4.49	10.8	4.62
		-18.8	-19.0	11.2	4.18	11.2	4.30	11.2	4.43	11.1	4.49	11.1	4.55	11.1	4.68
		-16.7	-17.0	11.9	4.31	11.8	4.42	11.8	4.54	11.8	4.60	11.8	4.66	11.8	4.78
		-14.7	-15.0	12.5	4.42	12.5	4.53	12.5	4.64	12.5	4.70	12.4	4.76	12.4	4.87
		-12.6	-13.0	13.2	4.53	13.2	4.63	13.1	4.74	13.1	4.79	13.1	4.84	12.6	4.64
		-10.5	-11.0	13.8	4.62	13.8	4.72	13.8	4.82	13.8	4.87	13.5	4.76	12.6	4.36
		-9.5	-10.0	14.2	4.67	14.1	4.76	14.1	4.86	13.9	4.82	13.5	4.62	12.6	4.23
		-8.5	-9.1	14.5	4.70	14.4	4.80	14.4	4.89	13.9	4.70	13.5	4.50	12.6	4.13
		-7.0	-7.6	15.0	4.76	14.9	4.86	14.4	4.69	13.9	4.50	13.5	4.32	12.6	3.96
		-5.0	-5.6	15.6	4.84	15.3	4.80	14.4	4.44	13.9	4.27	13.5	4.09	12.6	3.76
		-3.0	-3.7	16.2	4.90	15.3	4.56	14.4	4.23	13.9	4.06	13.5	3.90	12.6	3.59
		0.0	-0.7	16.3	4.56	15.3	4.24	14.4	3.93	13.9	3.78	13.5	3.64	12.6	3.34
		3.0	2.2	16.3	4.26	15.3	3.97	14.4	3.69	13.9	3.55	13.5	3.41	12.6	3.14
		5.0	4.1	16.3	4.09	15.3	3.81	14.4	3.54	13.9	3.41	13.5	3.28	12.6	3.02
		7.0	6.0	16.3	3.93	15.3	3.67	14.4	3.41	13.9	3.28	13.5	3.16	12.6	2.91
		9.0	7.9	16.3	3.79	15.3	3.53	14.4	3.29	13.9	3.16	13.5	3.05	12.6	2.81
		11.0	9.8	16.3	3.65	15.3	3.41	14.4	3.17	13.9	3.06	13.5	2.94	12.6	2.72
13.0	11.8	16.3	3.52	15.3	3.29	14.4	3.06	13.9	2.95	13.5	2.84	12.6	2.62		
15.0	13.7	16.3	3.40	15.3	3.18	14.4	2.96	13.9	2.86	13.5	2.75	12.6	2.54		
80	12.80	-19.8	-20.0	10.8	4.36	10.8	4.47	10.8	4.59	10.8	4.64	10.8	4.70	10.7	4.81
		-18.8	-19.0	11.2	4.42	11.1	4.53	11.1	4.64	11.1	4.70	11.1	4.75	11.1	4.86
		-16.7	-17.0	11.8	4.54	11.8	4.64	11.8	4.74	11.8	4.80	11.7	4.85	11.2	4.58
		-14.7	-15.0	12.5	4.64	12.4	4.74	12.4	4.84	12.4	4.87	12.0	4.67	11.2	4.28
		-12.6	-13.0	13.1	4.73	13.1	4.83	12.8	4.75	12.4	4.56	12.0	4.38	11.2	4.01
		-10.5	-11.0	13.8	4.82	13.6	4.83	12.8	4.47	12.4	4.29	12.0	4.12	11.2	3.78
		-9.5	-10.0	14.1	4.86	13.6	4.68	12.8	4.34	12.4	4.17	12.0	4.00	11.2	3.68
		-8.5	-9.1	14.4	4.89	13.6	4.56	12.8	4.23	12.4	4.06	12.0	3.90	11.2	3.59
		-7.0	-7.6	14.4	4.70	13.6	4.38	12.8	4.06	12.4	3.90	12.0	3.75	11.2	3.44
		-5.0	-5.6	14.4	4.46	13.6	4.15	12.8	3.85	12.4	3.70	12.0	3.56	11.2	3.27
		-3.0	-3.7	14.4	4.24	13.6	3.95	12.8	3.67	12.4	3.53	12.0	3.40	11.2	3.13
		0.0	-0.7	14.4	3.95	13.6	3.68	12.8	3.42	12.4	3.30	12.0	3.17	11.2	2.92
		3.0	2.2	14.4	3.70	13.6	3.45	12.8	3.21	12.4	3.10	12.0	2.98	11.2	2.75
		5.0	4.1	14.4	3.56	13.6	3.32	12.8	3.09	12.4	2.98	12.0	2.87	11.2	2.65
		7.0	6.0	14.4	3.42	13.6	3.20	12.8	2.98	12.4	2.87	12.0	2.76	11.2	2.56
		9.0	7.9	14.4	3.30	13.6	3.08	12.8	2.87	12.4	2.77	12.0	2.67	11.2	2.47
		11.0	9.8	14.4	3.18	13.6	2.98	12.8	2.78	12.4	2.68	12.0	2.58	11.2	2.39
13.0	11.8	14.4	3.07	13.6	2.87	12.8	2.68	12.4	2.59	12.0	2.49	11.2	2.31		
15.0	13.7	14.4	2.97	13.6	2.78	12.8	2.60	12.4	2.51	12.0	2.42	11.2	2.24		
70	11.20	-19.8	-20.0	10.8	4.61	10.8	4.71	10.7	4.81	10.7	4.86	10.5	4.74	9.76	4.34
		-18.8	-19.0	11.1	4.66	11.1	4.76	11.1	4.86	10.8	4.76	10.5	4.56	9.76	4.18
		-16.7	-17.0	11.8	4.76	11.7	4.86	11.2	4.60	10.8	4.42	10.5	4.24	9.76	3.89
		-14.7	-15.0	12.4	4.86	11.9	4.64	11.2	4.30	10.8	4.13	10.5	3.97	9.76	3.64
		-12.6	-13.0	12.6	4.68	11.9	4.35	11.2	4.03	10.8	3.88	10.5	3.73	9.76	3.43
		-10.5	-11.0	12.6	4.40	11.9	4.10	11.2	3.80	10.8	3.66	10.5	3.51	9.76	3.23
		-9.5	-10.0	12.6	4.27	11.9	3.98	11.2	3.69	10.8	3.55	10.5	3.42	9.76	3.15
		-8.5	-9.1	12.6	4.16	11.9	3.88	11.2	3.60	10.8	3.47	10.5	3.33	9.76	3.07
		-7.0	-7.6	12.6	4.00	11.9	3.72	11.2	3.46	10.8	3.33	10.5	3.20	9.76	2.96
		-5.0	-5.6	12.6	3.79	11.9	3.54	11.2	3.29	10.8	3.17	10.5	3.05	9.76	2.81
		-3.0	-3.7	12.6	3.62	11.9	3.38	11.2	3.14	10.8	3.03	10.5	2.91	9.76	2.69
		0.0	-0.7	12.6	3.37	11.9	3.15	11.2	2.94	10.8	2.83	10.5	2.73	9.76	2.52
		3.0	2.2	12.6	3.17	11.9	2.96	11.2	2.76	10.8	2.67	10.5	2.57	9.76	2.38
		5.0	4.1	12.6	3.05	11.9	2.85	11.2	2.66	10.8	2.57	10.5	2.48	9.76	2.29
		7.0	6.0	12.6	2.94	11.9	2.75	11.2	2.57	10.8	2.48	10.5	2.39	9.76	2.22
		9.0	7.9	12.6	2.83	11.9	2.66	11.2	2.48	10.8	2.40	10.5	2.31	9.76	2.14
		11.0	9.8	12.6	2.74	11.9	2.57	11.2	2.40	10.8	2.32	10.5	2.24	9.76	2.08
13.0	11.8	12.6	2.65	11.9	2.48	11.2	2.32	10.8	2.24	10.5	2.16	9.76	2.01		
15.0	13.7	12.6	2.56	11.9	2.41	11.2	2.25	10.8	2.18	10.5	2.10	9.76	1.95		
60	9.60	-19.8	-20.0	10.7	4.86	10.2	4.59	9.60	4.25	9.29	4.09	8.98	3.92	8.37	3.60
		-18.8	-19.0	10.8	4.75	10.2	4.42	9.60	4.10	9.29	3.94	8.98	3.78	8.37	3.48
		-16.7	-17.0	10.8	4.42	10.2	4.11	9.60	3.82	9.29	3.67	8.98	3.53	8.37	3.25
		-14.7	-15.0	10.8	4.13	10.2	3.85	9.60	3.57	9.29	3.44	8.98	3.31	8.37	3.05
		-12.6	-13.0	10.8	3.88	10.2	3.61	9.60	3.36	9.29	3.24	8.98	3.11	8.37	2.87
		-10.5	-11.0	10.8	3.65	10.2	3.41	9.60	3.17	9.29	3.06	8.98	2.94	8.37	2.72
		-9.5	-10.0	10.8	3.55	10.2	3.32	9.60	3.09	9.29	2.97	8.98	2.86	8.37	2.65
		-8.5	-9.1	10.8	3.46	10.2	3.24	9.60	3.01	9.29	2.91	8.98	2.80	8.37	2.59
		-7.0	-7.6	10.8	3.33	10.2	3.11	9.60	2.90	9.29	2.80	8.98	2.69	8.37	2.49
		-5.0	-5.6	10.8	3.17	10.2	2.96	9.60	2.76	9.29	2.66	8.98	2.57	8.37	2.38
		-3.0	-3.7	10.8	3.03	10.2	2.83	9.60	2.64	9.29	2.55	8.98	2.46	8.37	2.28
		0.0	-0.7	10.8	2.83	10.2	2.65	9.60	2.48	9.29	2.39	8.98	2.31	8.37	2.14
		3.0	2.2	10.8	2.66	10.2	2.50	9.60	2.34	9.29	2.26	8.98	2.18	8.37	2.02
		5.0	4.1	10.8	2.57	10.2	2.41	9.60	2.25	9.29	2.18	8.98	2.10	8.37	1.96
		7.0	6.0	10.8	2.48	10.2	2.33	9.60	2.18	9.29	2.11	8.98	2.03	8.37	1.89
		9.0	7.9	10.8	2.39	10.2	2.25	9.60	2.11	9.29	2.04	8.98	1.97	8.37	1.83
		11.0	9.8	10.8	2.32	10.2	2.18	9.60	2.04	9.29	1.97	8.98	1.91	8.37	1.78
13.0	11.8	10.8	2.24	10.2	2.11	9.60	1.98	9.29	1.91	8.98	1.85	8.37	1.72		
15.0	13.7	10.8	2.17	10.2	2.05	9.60	1.92	9.29	1.86	8.98	1.80	8.37	1.68		
50	8.00	-19.8	-20.0	9.03	3.95	8.51	3.68	8.00	3.42	7.74	3.29	7.49	3.17	6.97	2.92
		-18.8	-19.0	9.03	3.80	8.51	3.55	8.00	3.30	7.74	3.18	7.49	3.06	6.97	2.82
		-16.7	-17.0	9.03	3.55	8.51	3.31	8.00	3.08	7.74	2.97	7.49	2.86	6.97	2.64
		-14.7	-15.0	9.03	3.33	8.51	3.11	8.00	2.90	7.74	2.79	7.49	2.69	6.97	2.49
		-12.6													

3 Capacity tables

3 - 2 Heating capacity tables

RXYSQ6PAV1		TC: Total capacity (kW); PI: Power Input (kW) (Compressor + Outdoor fan motor)													
Combination (%)	Capacity index (kW)	Outdoor air temp.		Indoor air temp. (°CWB)											
				16.0		18.0		20.0		21.0		22.0		24.0	
		°CDB	°CWB	TC	PI	TC	PI	TC	PI	TC	PI	TC	PI	TC	PI
130	23.40	-19.8	-20.0	11.3	2.81	11.3	3.03	11.2	3.25	11.2	3.36	11.2	3.47	11.1	3.69
		-18.8	-19.0	11.6	2.93	11.6	3.14	11.6	3.35	11.5	3.46	11.5	3.56	11.5	3.78
		-16.7	-17.0	12.3	3.14	12.3	3.34	12.2	3.55	12.2	3.65	12.2	3.75	12.1	3.95
		-14.7	-15.0	13.0	3.34	12.9	3.53	12.9	3.72	12.9	3.81	12.8	3.91	12.8	4.10
		-12.6	-13.0	13.6	3.51	13.6	3.69	13.6	3.88	13.5	3.97	13.5	4.06	13.5	4.24
		-10.5	-11.0	14.3	3.67	14.3	3.84	14.2	4.02	14.2	4.10	14.2	4.19	14.1	4.36
		-9.5	-10.0	14.6	3.75	14.6	3.91	14.6	4.08	14.5	4.17	14.5	4.25	14.5	4.42
		-8.5	-9.1	14.9	3.81	14.9	3.97	14.9	4.14	14.8	4.22	14.8	4.30	14.8	4.47
		-7.0	-7.6	15.4	3.91	15.4	4.07	15.4	4.23	15.3	4.31	15.3	4.39	15.3	4.55
		-5.0	-5.6	16.1	4.03	16.1	4.19	16.0	4.34	16.0	4.41	16.0	4.49	15.9	4.64
		-3.0	-3.7	16.7	4.14	16.7	4.29	16.7	4.44	16.6	4.51	16.6	4.58	16.6	4.73
		0.0	-0.7	17.7	4.30	17.7	4.44	17.7	4.57	17.6	4.64	17.6	4.71	17.6	4.85
		3.0	2.2	18.7	4.43	18.7	4.57	18.6	4.70	18.6	4.76	18.6	4.83	18.5	4.96
		5.0	4.1	19.3	4.52	19.3	4.64	19.3	4.77	19.2	4.83	19.2	4.89	19.2	5.02
		7.0	6.0	20.0	4.59	19.9	4.71	19.9	4.84	19.9	4.90	19.9	4.96	19.8	5.08
		9.0	7.9	20.6	4.66	20.6	4.78	20.5	4.90	20.5	4.96	20.5	5.02	20.4	5.11
		11.0	9.8	21.3	4.73	21.2	4.85	21.2	4.96	21.1	5.02	21.1	5.08	21.0	4.93
13.0	11.8	21.9	4.80	21.9	4.91	21.8	5.02	21.8	5.08	21.8	5.13	21.7	4.74		
15.0	13.7	22.6	4.86	22.5	4.97	22.5	5.07	22.4	5.13	21.9	4.99	20.4	4.58		
120	21.60	-19.8	-20.0	11.2	3.10	11.2	3.31	11.2	3.51	11.2	3.61	11.1	3.71	11.1	3.91
		-18.8	-19.0	11.6	3.21	11.5	3.41	11.5	3.61	11.5	3.71	11.5	3.80	11.4	4.00
		-16.7	-17.0	12.2	3.42	12.2	3.60	12.2	3.79	12.2	3.88	12.1	3.97	12.1	4.16
		-14.7	-15.0	12.9	3.60	12.9	3.77	12.8	3.95	12.8	4.03	12.8	4.12	12.8	4.30
		-12.6	-13.0	13.6	3.76	13.5	3.92	13.5	4.09	13.5	4.17	13.5	4.26	13.4	4.42
		-10.5	-11.0	14.3	3.90	14.2	4.06	14.2	4.22	14.2	4.30	14.1	4.38	14.1	4.54
		-9.5	-10.0	14.6	3.97	14.5	4.13	14.5	4.28	14.5	4.36	14.5	4.44	14.4	4.59
		-8.5	-9.1	14.9	4.03	14.8	4.18	14.8	4.34	14.8	4.41	14.8	4.49	14.7	4.64
		-7.0	-7.6	15.4	4.13	15.3	4.27	15.3	4.42	15.3	4.49	15.3	4.56	15.2	4.71
		-5.0	-5.6	16.1	4.24	16.0	4.38	16.0	4.52	16.0	4.59	15.9	4.66	15.9	4.80
		-3.0	-3.7	16.7	4.34	16.6	4.48	16.6	4.61	16.6	4.68	16.6	4.75	16.5	4.88
		0.0	-0.7	17.7	4.49	17.7	4.61	17.6	4.74	17.6	4.80	17.6	4.87	17.5	4.99
		3.0	2.2	18.7	4.61	18.6	4.73	18.6	4.85	18.6	4.91	18.5	4.97	18.5	5.09
		5.0	4.1	19.3	4.69	19.3	4.80	19.2	4.92	19.2	4.98	19.2	5.04	18.8	5.02
		7.0	6.0	19.9	4.76	19.9	4.87	19.9	4.98	19.8	5.04	19.8	5.09	19.8	4.82
		9.0	7.9	20.6	4.82	20.5	4.93	20.5	5.04	20.5	5.10	20.2	5.06	18.8	4.64
		11.0	9.8	21.2	4.89	21.2	4.99	21.1	5.10	20.9	5.08	20.2	4.87	18.8	4.47
13.0	11.8	21.9	4.95	21.8	5.05	21.6	5.08	20.9	4.89	20.2	4.69	18.8	4.31		
15.0	13.7	22.5	5.00	22.5	5.10	21.6	4.91	20.9	4.72	20.2	4.53	18.8	4.17		
110	19.80	-19.8	-20.0	11.2	3.40	11.2	3.59	11.1	3.77	11.1	3.86	11.1	3.96	11.1	4.14
		-18.8	-19.0	11.5	3.50	11.5	3.68	11.5	3.86	11.4	3.95	11.4	4.04	11.4	4.22
		-16.7	-17.0	12.2	3.69	12.2	3.86	12.1	4.03	12.1	4.11	12.1	4.20	12.1	4.37
		-14.7	-15.0	12.9	3.85	12.8	4.01	12.8	4.17	12.8	4.25	12.8	4.34	12.7	4.50
		-12.6	-13.0	13.5	4.00	13.5	4.15	13.5	4.31	13.4	4.38	13.4	4.46	13.4	4.61
		-10.5	-11.0	14.2	4.14	14.2	4.28	14.1	4.43	14.1	4.50	14.1	4.57	14.1	4.72
		-9.5	-10.0	14.5	4.20	14.5	4.34	14.5	4.48	14.4	4.55	14.4	4.63	14.4	4.77
		-8.5	-9.1	14.8	4.25	14.8	4.39	14.8	4.53	14.7	4.60	14.7	4.67	14.7	4.81
		-7.0	-7.6	15.3	4.34	15.3	4.47	15.3	4.61	15.2	4.68	15.2	4.74	15.2	4.88
		-5.0	-5.6	16.0	4.45	16.0	4.57	15.9	4.70	15.9	4.77	15.9	4.83	15.9	4.96
		-3.0	-3.7	16.6	4.54	16.6	4.66	16.6	4.79	16.5	4.85	16.5	4.91	16.5	5.03
		0.0	-0.7	17.6	4.67	17.6	4.79	17.6	4.90	17.5	4.96	17.5	5.02	17.3	5.03
		3.0	2.2	18.6	4.79	18.6	4.90	18.5	5.01	18.5	5.06	18.5	5.12	17.3	4.71
		5.0	4.1	19.2	4.86	19.2	4.96	19.2	5.07	19.1	5.12	18.5	4.92	17.3	4.52
		7.0	6.0	19.9	4.92	19.8	5.02	19.8	5.13	19.2	4.93	18.5	4.73	17.3	4.35
		9.0	7.9	20.5	4.98	20.5	5.08	19.8	4.93	19.2	4.74	18.5	4.55	17.3	4.19
		11.0	9.8	21.1	5.04	21.1	5.13	19.8	4.75	19.2	4.57	18.5	4.39	17.3	4.04
13.0	11.8	21.8	5.10	21.1	4.93	19.8	4.58	19.2	4.40	18.5	4.23	17.3	3.89		
15.0	13.7	22.3	5.12	21.1	4.76	19.8	4.42	19.2	4.26	18.5	4.09	17.3	3.77		
100	18.00	-19.8	-20.0	11.1	3.70	11.1	3.87	11.1	4.03	11.1	4.12	11.0	4.20	11.0	4.37
		-18.8	-19.0	11.5	3.79	11.4	3.95	11.4	4.12	11.4	4.20	11.4	4.28	11.3	4.44
		-16.7	-17.0	12.1	3.96	12.1	4.11	12.1	4.27	12.1	4.34	12.0	4.42	12.0	4.58
		-14.7	-15.0	12.8	4.11	12.8	4.26	12.7	4.40	12.7	4.48	12.7	4.55	12.7	4.69
		-12.6	-13.0	13.5	4.25	13.4	4.38	13.4	4.52	13.4	4.59	13.4	4.66	13.3	4.80
		-10.5	-11.0	14.1	4.37	14.1	4.50	14.1	4.63	14.1	4.70	14.0	4.77	14.0	4.90
		-9.5	-10.0	14.5	4.43	14.4	4.56	14.4	4.68	14.4	4.75	14.4	4.81	14.3	4.94
		-8.5	-9.1	14.8	4.48	14.7	4.60	14.7	4.73	14.7	4.79	14.7	4.85	14.6	4.98
		-7.0	-7.6	15.3	4.55	15.2	4.68	15.2	4.80	15.2	4.86	15.2	4.92	15.1	5.04
		-5.0	-5.6	15.9	4.65	15.9	4.77	15.9	4.88	15.9	4.94	15.8	5.00	15.7	5.05
		-3.0	-3.7	16.6	4.74	16.5	4.85	16.5	4.96	16.5	5.02	16.5	5.07	15.7	4.81
		0.0	-0.7	17.6	4.86	17.5	4.96	17.5	5.07	17.4	5.09	16.8	4.88	15.7	4.48
		3.0	2.2	18.5	4.96	18.5	5.06	18.0	4.95	17.4	4.76	16.8	4.57	15.7	4.20
		5.0	4.1	19.2	5.03	19.1	5.12	18.0	4.75	17.4	4.57	16.8	4.39	15.7	4.04
		7.0	6.0	19.8	5.09	19.2	4.93	18.0	4.57	17.4	4.40	16.8	4.22	15.7	3.89
		9.0	7.9	20.3	5.09	19.2	4.74	18.0	4.40	17.4	4.23	16.8	4.07	15.7	3.75
		11.0	9.8	20.3	4.90	19.2	4.57	18.0	4.24	17.4	4.08	16.8	3.93	15.7	3.62
13.0	11.8	20.3	4.72	19.2	4.40	18.0	4.09	17.4	3.94	16.8	3.79	15.7	3.49		
15.0	13.7	20.3	4.56	19.2	4.25	18.0	3.96	17.4	3.81	16.8	3.66	15.7	3.38		

4TW30372-2

NOTE

1 The above table shows the average value of conditions which may occur.

3 Capacity tables

3 - 2 Heating capacity tables

RXYSQ6PAV1				Indoor air temp. (°CWB)											
Combination (%)	Capacity index (kW)	Outdoor air temp.		16.0		18.0		20.0		21.0		22.0		24.0	
		°CDB	°CWB	TC	PI	TC	PI	TC	PI	TC	PI	TC	PI	TC	PI
				kW	kW	kW	kW	kW	kW	kW	kW	kW	kW	kW	kW
90	16.20	-19.8	-20.0	11.1	3.99	11.1	4.15	11.0	4.30	11.0	4.37	11.0	4.45	11.0	4.60
		-18.8	-19.0	11.4	4.08	11.4	4.22	11.4	4.37	11.3	4.45	11.3	4.52	11.3	4.67
		-16.7	-17.0	12.1	4.23	12.1	4.37	12.0	4.51	12.0	4.58	12.0	4.65	12.0	4.79
		-14.7	-15.0	12.7	4.37	12.7	4.50	12.7	4.63	12.7	4.70	12.7	4.76	12.6	4.89
		-12.6	-13.0	13.4	4.49	13.4	4.61	13.4	4.74	13.3	4.80	13.3	4.86	13.3	4.99
		-10.5	-11.0	14.1	4.60	14.1	4.72	14.0	4.84	14.0	4.90	14.0	4.96	14.0	5.08
		-9.5	-10.0	14.4	4.65	14.4	4.77	14.4	4.88	14.3	4.94	14.3	5.00	14.1	5.01
		-8.5	-9.1	14.7	4.70	14.7	4.81	14.7	4.92	14.6	4.98	14.6	5.04	14.1	4.89
		-7.0	-7.6	15.2	4.77	15.2	4.88	15.2	4.99	15.1	5.04	15.1	5.10	14.1	4.69
		-5.0	-5.6	15.9	4.86	15.9	4.96	15.8	5.07	15.7	5.05	15.2	4.85	14.1	4.45
		-3.0	-3.7	16.5	4.93	16.5	5.03	16.2	5.01	15.7	4.81	15.2	4.62	14.1	4.25
		0.0	-0.7	17.5	5.04	17.2	5.02	16.2	4.66	15.7	4.48	15.2	4.30	14.1	3.96
		3.0	2.2	18.3	5.05	17.2	4.70	16.2	4.37	15.7	4.20	15.2	4.04	14.1	3.72
		5.0	4.1	18.3	4.84	17.2	4.51	16.2	4.19	15.7	4.04	15.2	3.88	14.1	3.58
		7.0	6.0	18.3	4.66	17.2	4.34	16.2	4.04	15.7	3.89	15.2	3.74	14.1	3.45
		9.0	7.9	18.3	4.48	17.2	4.18	16.2	3.89	15.7	3.75	15.2	3.61	14.1	3.33
		11.0	9.8	18.3	4.32	17.2	4.03	16.2	3.75	15.7	3.62	15.2	3.48	14.1	3.22
13.0	11.8	18.3	4.17	17.2	3.89	16.2	3.62	15.7	3.49	15.2	3.36	14.1	3.11		
15.0	13.7	18.3	4.03	17.2	3.76	16.2	3.51	15.7	3.38	15.2	3.26	14.1	3.01		
80	14.40	-19.8	-20.0	11.0	4.29	11.0	4.43	11.0	4.56	11.0	4.63	10.9	4.70	10.9	4.83
		-18.8	-19.0	11.4	4.36	11.3	4.50	11.3	4.63	11.3	4.69	11.3	4.76	11.3	4.89
		-16.7	-17.0	12.0	4.50	12.0	4.62	12.0	4.75	12.0	4.81	11.9	4.87	11.9	5.00
		-14.7	-15.0	12.7	4.62	12.7	4.74	12.6	4.86	12.6	4.92	12.6	4.97	12.6	5.07
		-12.6	-13.0	13.4	4.73	13.3	4.84	13.3	4.96	13.3	5.01	13.3	5.07	12.6	4.75
		-10.5	-11.0	14.0	4.83	14.0	4.94	14.0	5.04	13.9	5.08	13.5	4.88	12.6	4.48
		-9.5	-10.0	14.4	4.88	14.3	4.98	14.3	5.09	13.9	4.94	13.5	4.74	12.6	4.35
		-8.5	-9.1	14.7	4.92	14.6	5.02	14.4	5.01	13.9	4.81	13.5	4.62	12.6	4.24
		-7.0	-7.6	15.2	4.98	15.1	5.08	14.4	4.80	13.9	4.62	13.5	4.44	12.6	4.08
		-5.0	-5.6	15.8	5.06	15.3	4.91	14.4	4.56	13.9	4.38	13.5	4.21	12.6	3.88
		-3.0	-3.7	16.3	5.03	15.3	4.68	14.4	4.35	13.9	4.18	13.5	4.02	12.6	3.70
		0.0	-0.7	16.3	4.68	15.3	4.36	14.4	4.05	13.9	3.90	13.5	3.75	12.6	3.46
		3.0	2.2	16.3	4.38	15.3	4.09	14.4	3.81	13.9	3.67	13.5	3.53	12.6	3.26
		5.0	4.1	16.3	4.21	15.3	3.93	14.4	3.66	13.9	3.53	13.5	3.40	12.6	3.14
		7.0	6.0	16.3	4.05	15.3	3.79	14.4	3.53	13.9	3.40	13.5	3.27	12.6	3.03
		9.0	7.9	16.3	3.90	15.3	3.65	14.4	3.40	13.9	3.28	13.5	3.16	12.6	2.92
		11.0	9.8	16.3	3.77	15.3	3.53	14.4	3.29	13.9	3.17	13.5	3.06	12.6	2.83
13.0	11.8	16.3	3.64	15.3	3.40	14.4	3.18	13.9	3.06	13.5	2.95	12.6	2.74		
15.0	13.7	16.3	3.52	15.3	3.30	14.4	3.08	13.9	2.97	13.5	2.86	12.6	2.65		
70	12.60	-19.8	-20.0	11.0	4.59	10.9	4.71	10.9	4.82	10.9	4.88	10.9	4.94	10.9	5.06
		-18.8	-19.0	11.3	4.65	11.3	4.77	11.3	4.88	11.2	4.94	11.2	5.00	11.0	4.95
		-16.7	-17.0	12.0	4.77	11.9	4.88	11.9	4.99	11.9	5.04	11.8	5.02	11.0	4.61
		-14.7	-15.0	12.6	4.88	12.6	4.98	12.6	5.08	12.2	4.89	11.8	4.70	11.0	4.31
		-12.6	-13.0	13.3	4.98	13.3	5.07	12.6	4.78	12.2	4.59	11.8	4.41	11.0	4.06
		-10.5	-11.0	14.0	5.06	13.4	4.85	12.6	4.50	12.2	4.33	11.8	4.16	11.0	3.83
		-9.5	-10.0	14.2	5.06	13.4	4.71	12.6	4.37	12.2	4.21	11.8	4.04	11.0	3.73
		-8.5	-9.1	14.2	4.93	13.4	4.59	12.6	4.27	12.2	4.10	11.8	3.95	11.0	3.64
		-7.0	-7.6	14.2	4.73	13.4	4.41	12.6	4.10	12.2	3.94	11.8	3.79	11.0	3.50
		-5.0	-5.6	14.2	4.49	13.4	4.19	12.6	3.89	12.2	3.75	11.8	3.61	11.0	3.33
		-3.0	-3.7	14.2	4.28	13.4	4.00	12.6	3.72	12.2	3.58	11.8	3.45	11.0	3.19
		0.0	-0.7	14.2	3.99	13.4	3.73	12.6	3.48	12.2	3.35	11.8	3.23	11.0	2.99
		3.0	2.2	14.2	3.75	13.4	3.51	12.6	3.27	12.2	3.16	11.8	3.04	11.0	2.82
		5.0	4.1	14.2	3.61	13.4	3.38	12.6	3.15	12.2	3.04	11.8	2.93	11.0	2.72
		7.0	6.0	14.2	3.48	13.4	3.26	12.6	3.04	12.2	2.93	11.8	2.83	11.0	2.62
		9.0	7.9	14.2	3.35	13.4	3.14	12.6	2.94	12.2	2.84	11.8	2.74	11.0	2.54
		11.0	9.8	14.2	3.24	13.4	3.04	12.6	2.84	12.2	2.74	11.8	2.65	11.0	2.46
13.0	11.8	14.2	3.13	13.4	2.94	12.6	2.75	12.2	2.66	11.8	2.56	11.0	2.38		
15.0	13.7	14.2	3.03	13.4	2.85	12.6	2.67	12.2	2.58	11.8	2.49	11.0	2.31		
60	10.80	-19.8	-20.0	10.9	4.88	10.9	4.99	10.8	5.03	10.5	4.84	10.1	4.64	9.41	4.27
		-18.8	-19.0	11.2	4.94	11.2	5.04	10.8	4.85	10.5	4.66	10.1	4.48	9.41	4.12
		-16.7	-17.0	11.9	5.04	11.5	4.87	10.8	4.52	10.5	4.35	10.1	4.18	9.41	3.84
		-14.7	-15.0	12.2	4.89	11.5	4.55	10.8	4.23	10.5	4.07	10.1	3.91	9.41	3.61
		-12.6	-13.0	12.2	4.59	11.5	4.28	10.8	3.98	10.5	3.83	10.1	3.69	9.41	3.40
		-10.5	-11.0	12.2	4.32	11.5	4.04	10.8	3.76	10.5	3.62	10.1	3.48	9.41	3.22
		-9.5	-10.0	12.2	4.20	11.5	3.93	10.8	3.66	10.5	3.52	10.1	3.39	9.41	3.13
		-8.5	-9.1	12.2	4.10	11.5	3.83	10.8	3.57	10.5	3.44	10.1	3.31	9.41	3.06
		-7.0	-7.6	12.2	3.94	11.5	3.68	10.8	3.43	10.5	3.31	10.1	3.19	9.41	2.95
		-5.0	-5.6	12.2	3.75	11.5	3.51	10.8	3.27	10.5	3.15	10.1	3.04	9.41	2.81
		-3.0	-3.7	12.2	3.58	11.5	3.35	10.8	3.13	10.5	3.02	10.1	2.91	9.41	2.70
		0.0	-0.7	12.2	3.35	11.5	3.14	10.8	2.93	10.5	2.83	10.1	2.73	9.41	2.53
		3.0	2.2	12.2	3.15	11.5	2.96	10.8	2.77	10.5	2.67	10.1	2.58	9.41	2.40
		5.0	4.1	12.2	3.04	11.5	2.85	10.8	2.67	10.5	2.58	10.1	2.49	9.41	2.31
		7.0	6.0	12.2	2.93	11.5	2.75	10.8	2.58	10.5	2.49	10.1	2.41	9.41	2.24
		9.0	7.9	12.2	2.83	11.5	2.66	10.8	2.50	10.5	2.41	10.1	2.33	9.41	2.17
		11.0	9.8	12.2	2.74	11.5	2.58	10.8	2.42	10.5	2.34	10.1	2.26	9.41	2.10
13.0	11.8	12.2	2.65	11.5	2.50	10.8	2.34	10.5	2.27	10.1	2.19	9.41	2.04		
15.0	13.7	12.2	2.57	11.5	2.42	10.8	2.27	10.5	2.20	10.1	2.13	9.41	1.98		
50	9.00	-19.8	-20.0	10.2	4.67	9.58	4.36	9.00	4.05	8.71	3.90	8.42	3.75	7.84	3.46
		-18.8	-19.0	10.2	4.50	9.58	4.20	9.00	3.91	8.71	3.76	8.42	3.62	7.84	3.34
		-16.7	-17.0	10.2	4.20	9.58	3.92	9.00	3.65	8.71	3.52	8.42	3.39	7.84	3.13
		-14.7	-15.0	10.2	3.94	9.58	3.68	9.00	3.43	8.71	3.31	8.42	3.18	7.84	2.95

4 Dimensional drawing & centre of gravity

4 - 1 Dimensional drawing

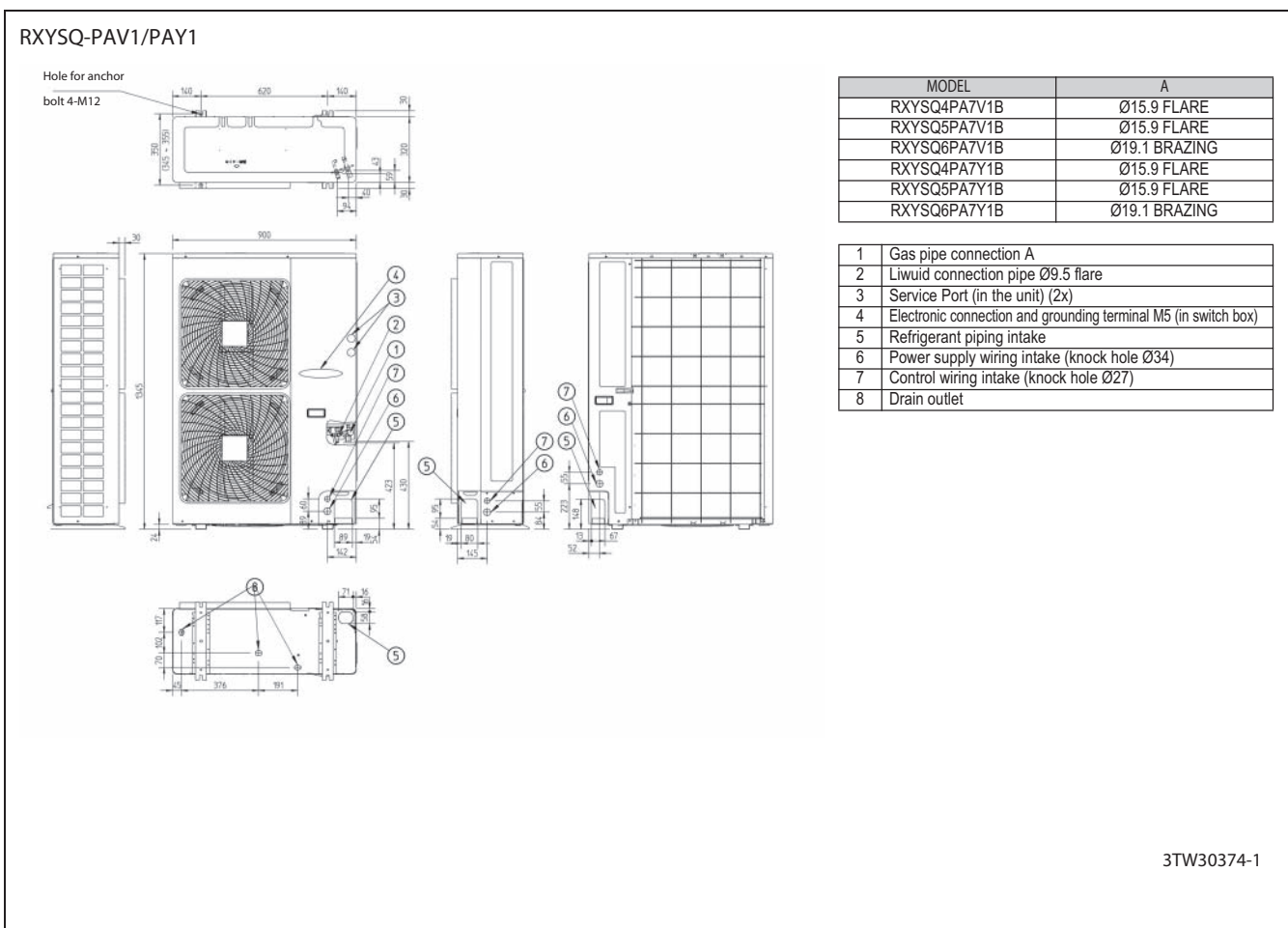

4 Dimensional drawing & centre of gravity

4 - 2 Centre of gravity

RXYSQ-PV

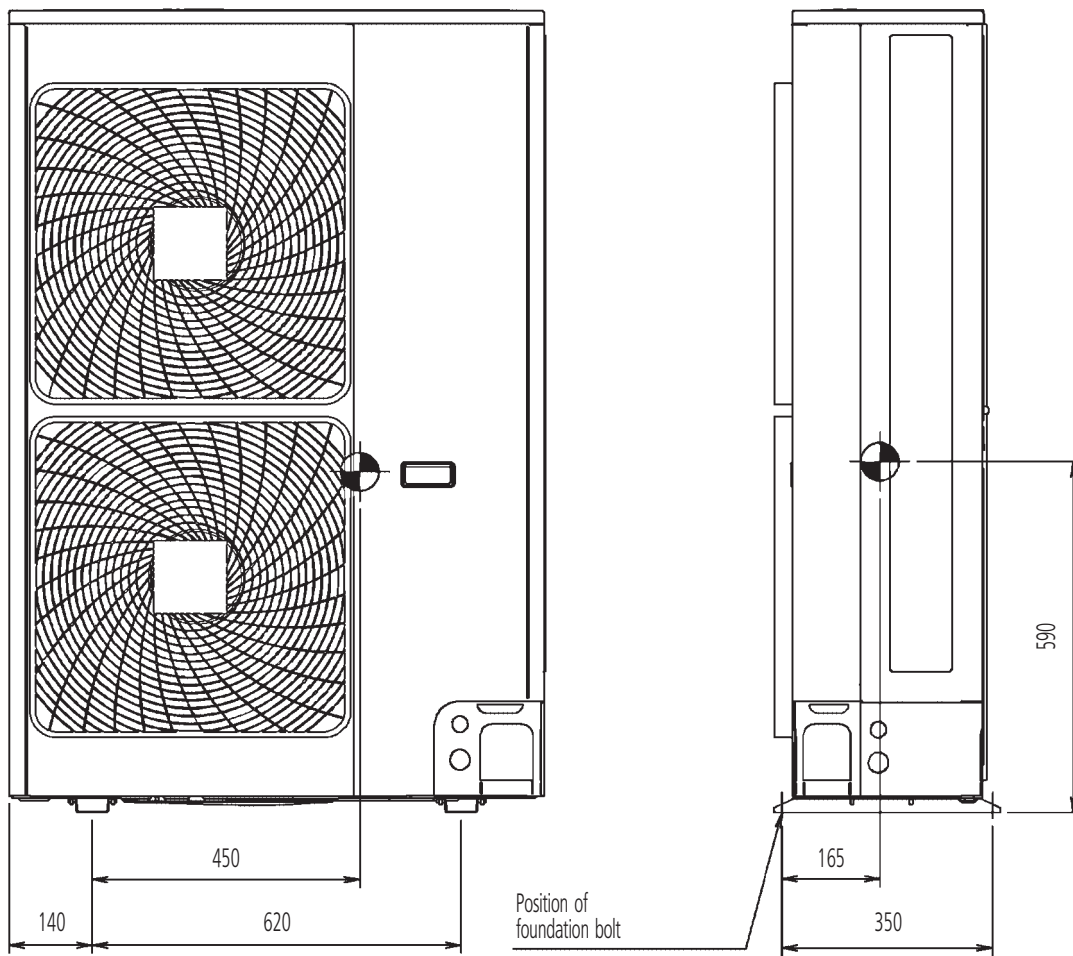

4D052604

5 Piping diagram

RXYSQ-PV

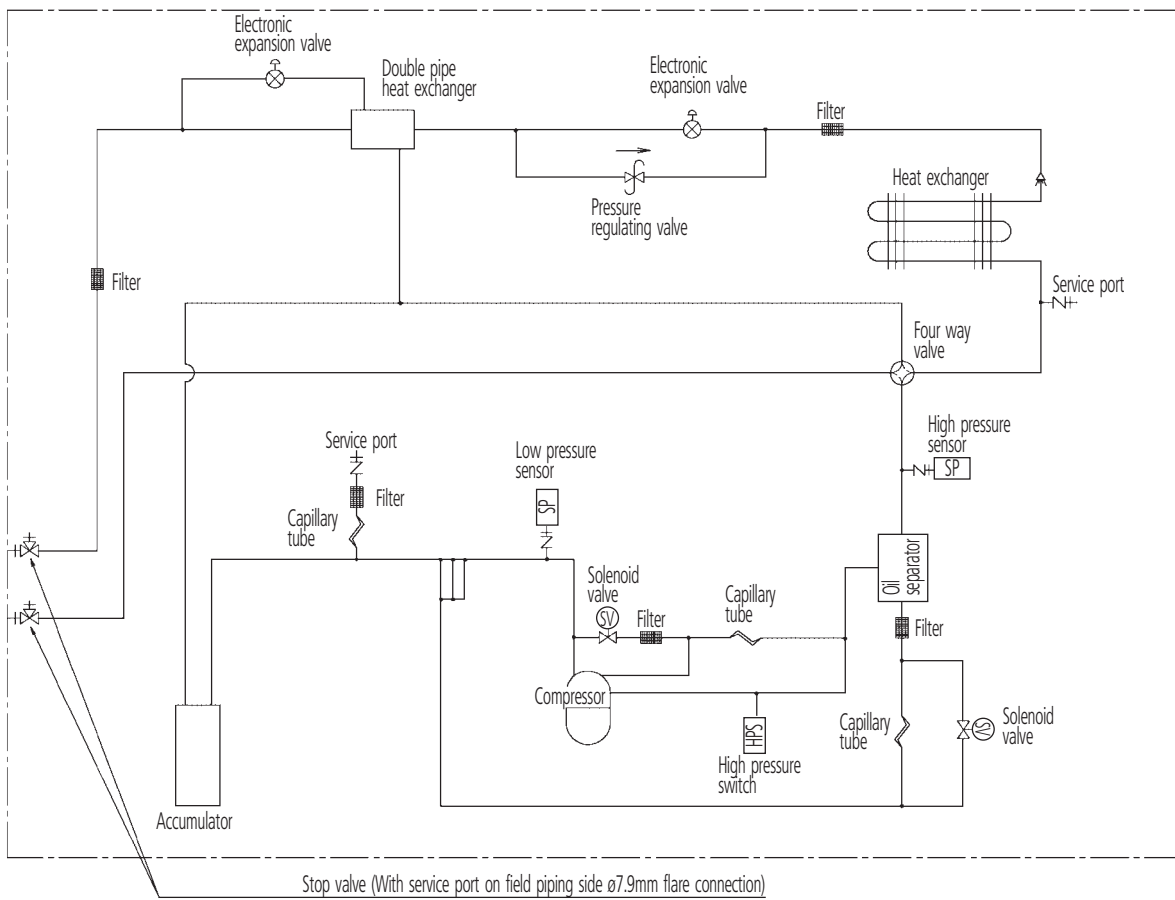

10
5

3D052712

6 Wiring diagram

6 - 1 Wiring diagram

RXYSQ-PAV1

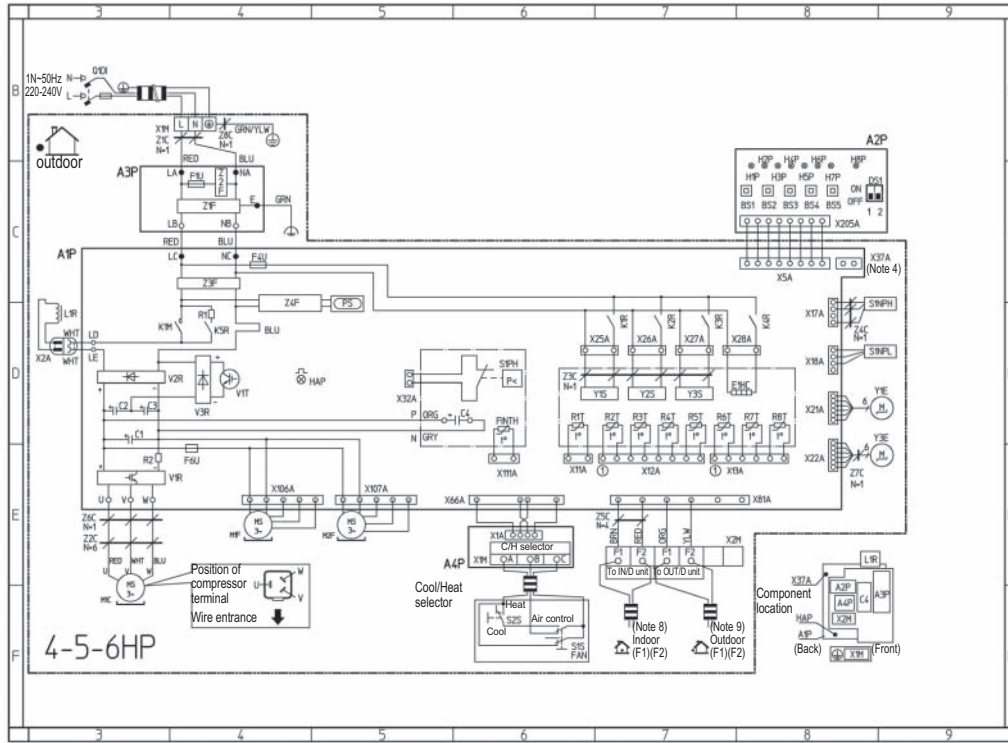

S1S	Selector switch (Fan / Cool - Heat)	HAP (A1P)	Light Emitting Diode (Service Monitor Green)	R6T	Thermistor (Subcooling H.EX)
S2S	Selector switch (Cool - Heat)	K1M	Magnetic contactor (M1C)	R7T	Thermistor (Liquid pipe 1)
Connector of Option Adaptor		K1R	Magnetic Relay (Y1S)	R8T	Thermistor (Liquid pipe 2)
X37A (Note 4)	Connector (Option Adaptor Power Supply)	K2R	Magnetic Relay (Y2S)	S1NPH	Pressure Sensor (High)
A1P	Printed Circuit Board (Main)	K3R	Magnetic Relay (Y3S)	S1NPL	Pressure Sensor (Low)
A2P	Printed Circuit Board (Inv.)	K4R	Magnetic Relay (E1HC)	S1PH	Pressure Switch (high)
A3P	Printed Circuit Board (Noise Filter)	L1R	Reactor	V1R	Power Module
A4P	Printed Circuit Board (C/H Selector)	M1C	Motor (Compressor)	V2R,V3R	Diode Module
BS1-BS5	Push button Switch (Mode, Set, Return, Test, Reset)	M1F	Motor (Fan) (Upper)	V1T	IGBT
C1-C4	Capacitor	M2F	Motor (Fan) (Lower)	X1M	Terminal Strip (Power Supply)
DS1	Dip Switch	PS	Switching Power Supply	X2M	Terminal Strip (Control)
E1HC	Crankcase heater	Q1DI	Field Earth Leakage breaker (300mA)	X1M	Terminal Strip (C/H Selector)(A4P)
F1, F4U	Fuse (T 6.3A / 250V)	R1	Resistor	Y1E	Electronic Expansion Valve (Main)
F6U	Fuse (T 5.0A / 250V)	R2	Resistor	Y2S	Solenoid Valve (Hot Gas)
FINTH	Thermistor (Fin)	R1T	Thermistor (Air)	Y3S	Solenoid Valve (U/L Circuit)
H1P-H8P	Light Emit. Diode (Serv. monitor-Orange)	R2T	Thermistor (Discharge)	Z1C-Z8C	Noise filter (Ferrity Core)
	Prepare, Test Flickering	R3T	Thermistor (Suction 1)	Z1F-Z4F	Noise Filter
	[H2P] Malfunction detection Light up	R4T	Thermistor (Heat Exchanger)		
		R5T	Thermistor (Suction 2)		

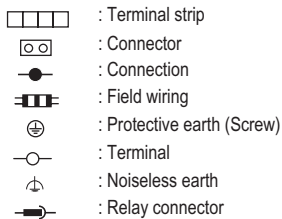

Colors: BLU: Blue BRN: Brown GRN: Green
 RED: Red WHT: White YLW: Yellow
 ORG: Orange

2TW30376-1

NOTES

- 1 This wiring diagram only applies to the outdoor unit
- 2 L: Live N: Neutral
- 3 When using the option adaptor, refer to the installation manual
- 4 Refer to the 'Wiring Diagram Sticker' (on back of front plate) on how to use BS1 ~ BS5 and DS1, DS2 switch
- 5 Do not operate the unit by short-circuiting protection device S1PH
- 6 Refer to the installation manual for connection wiring to indoor - outdoor transmission F1-F2
- 7 When using the central control system, connect outdoor - outdoor transmission F1-F2

6 Wiring diagram

6 - 2 External connection diagram

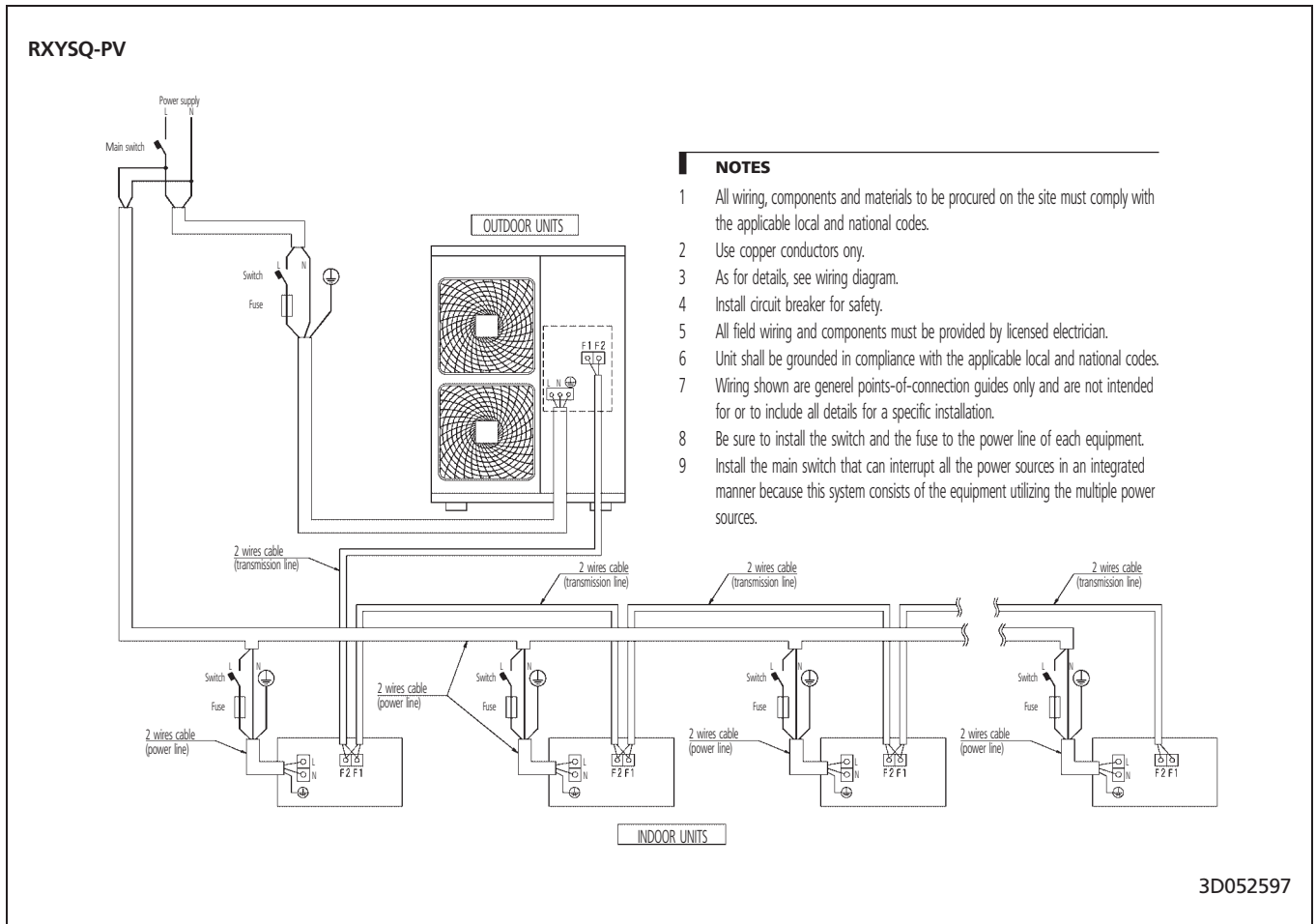

7 Sound data

7 - 1 Sound pressure spectrum

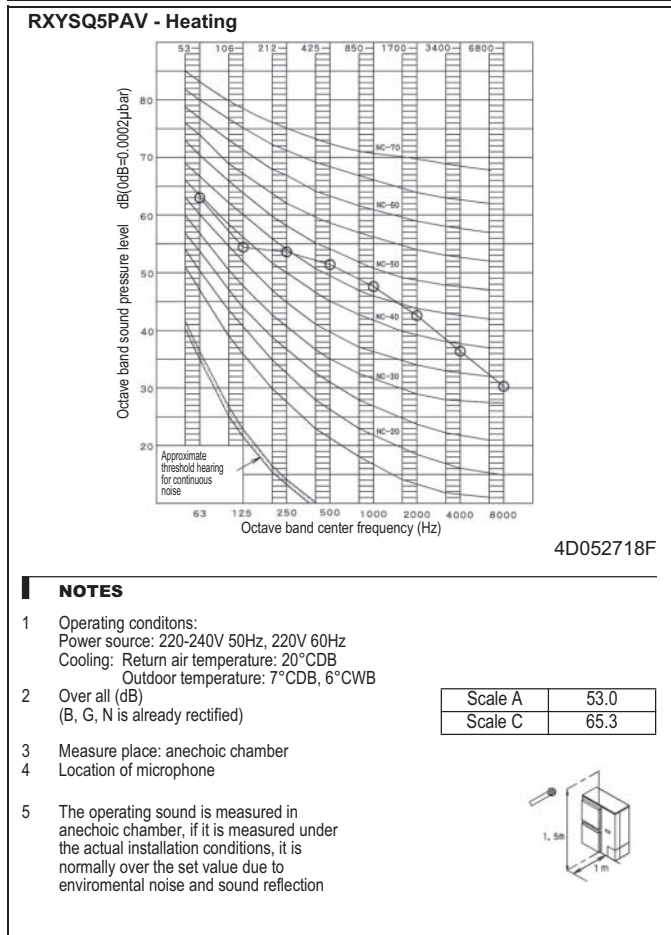
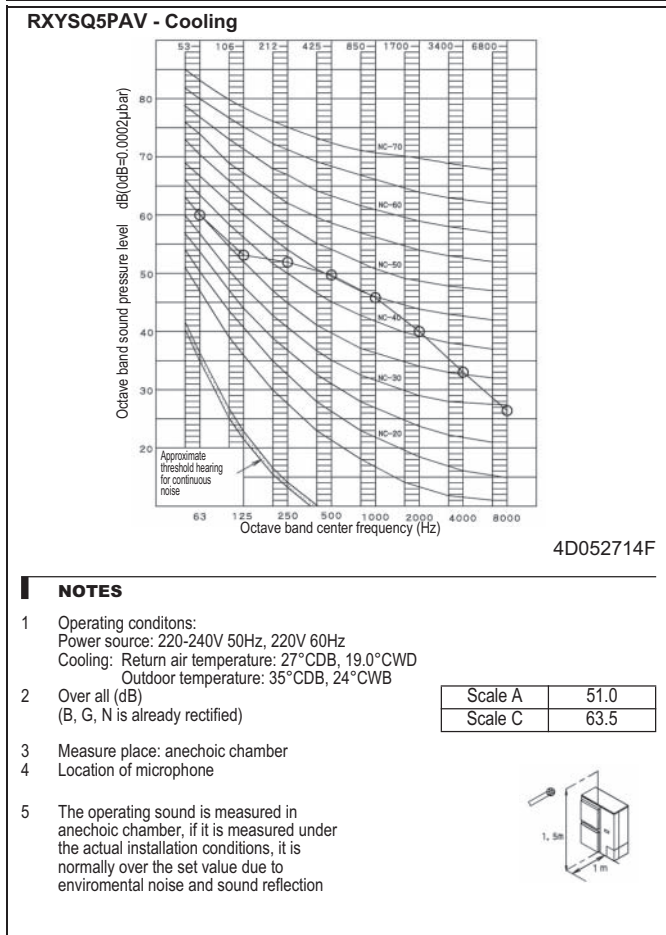
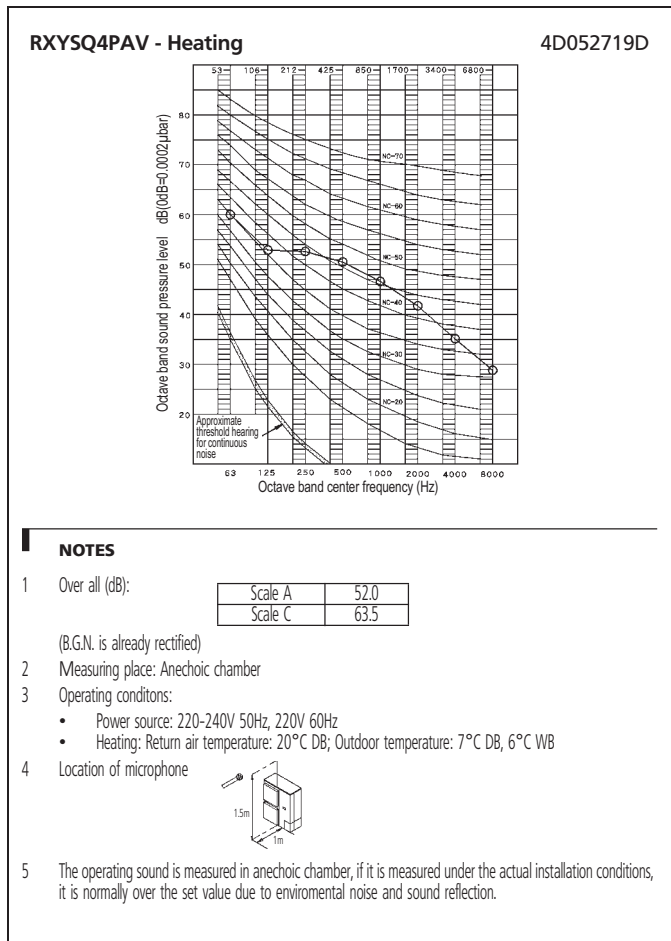
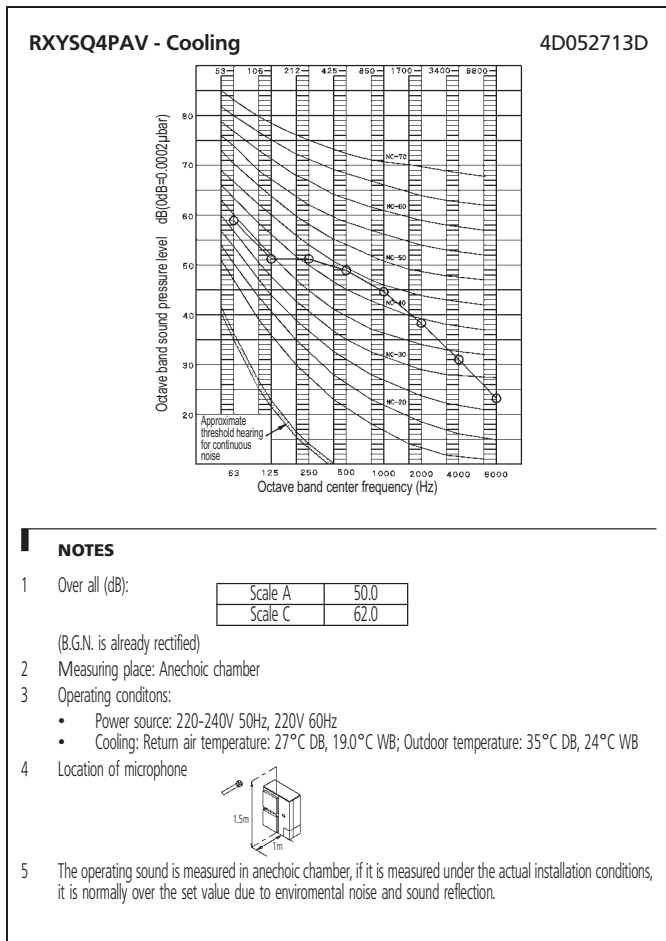

7 Sound data

7 - 1 Sound pressure spectrum

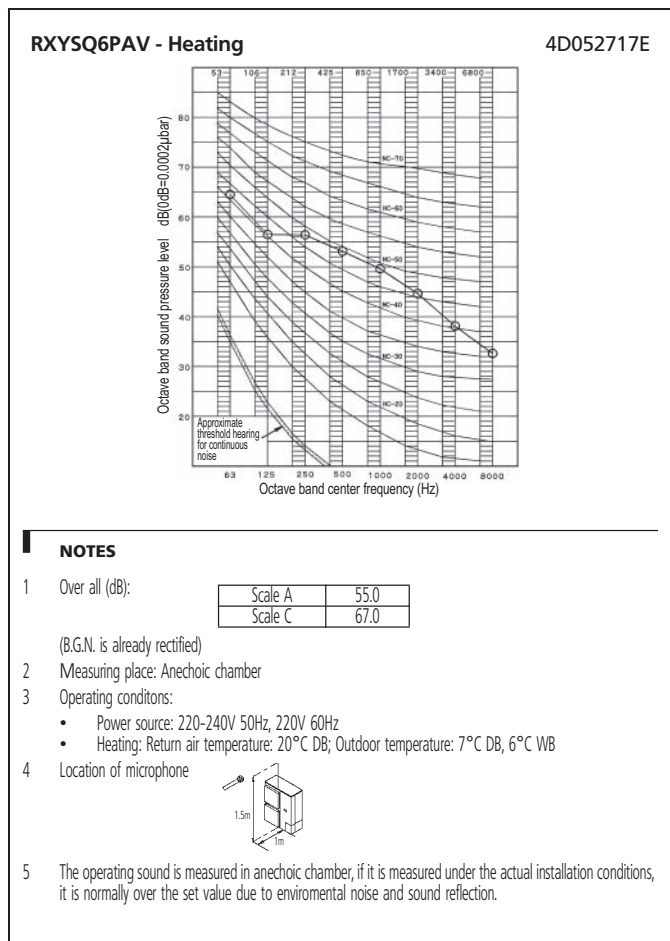
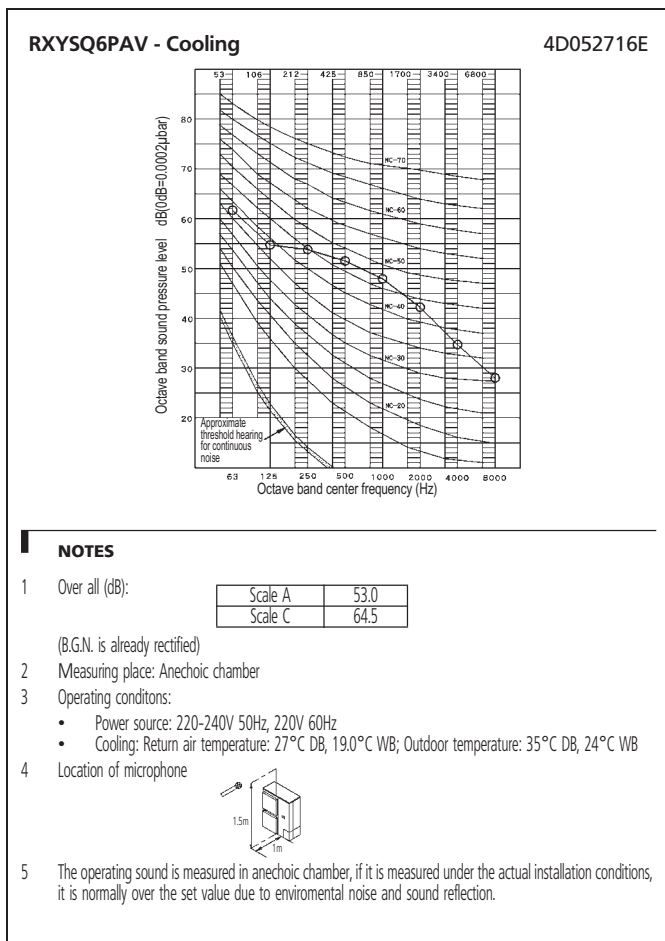

7 Sound data

7 - 2 Sound power spectrum

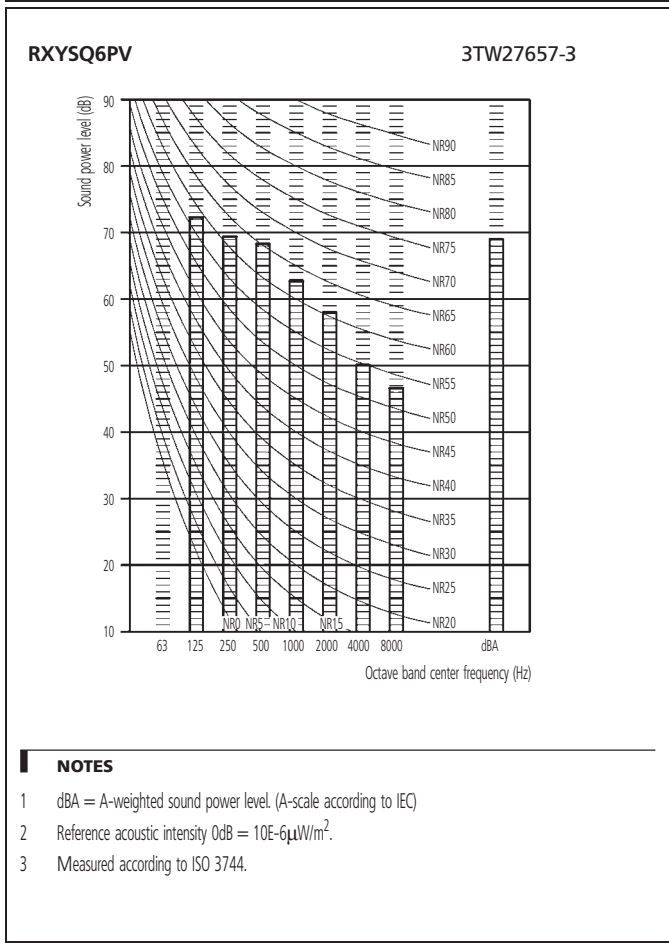
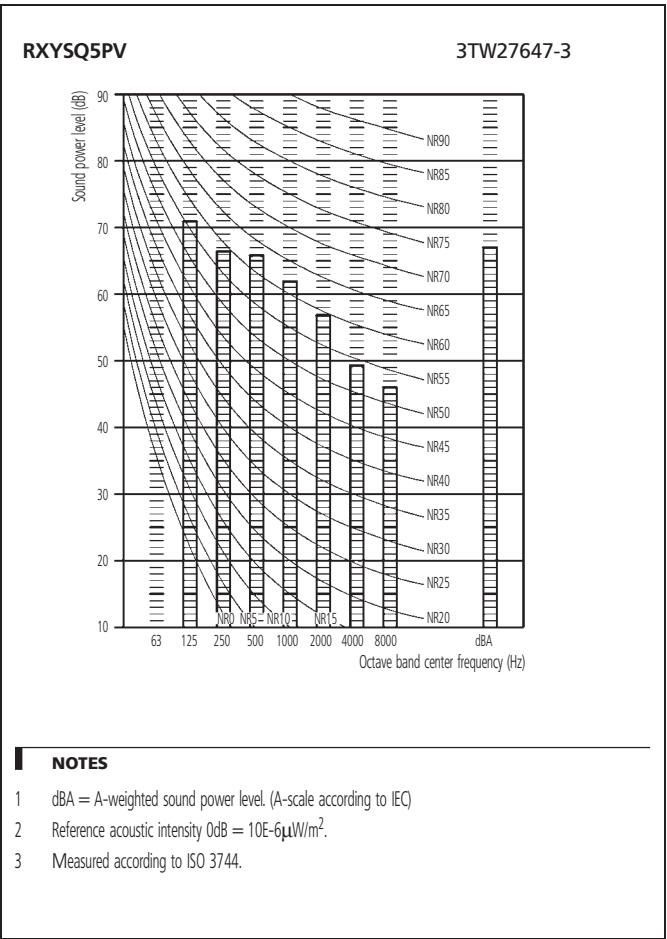
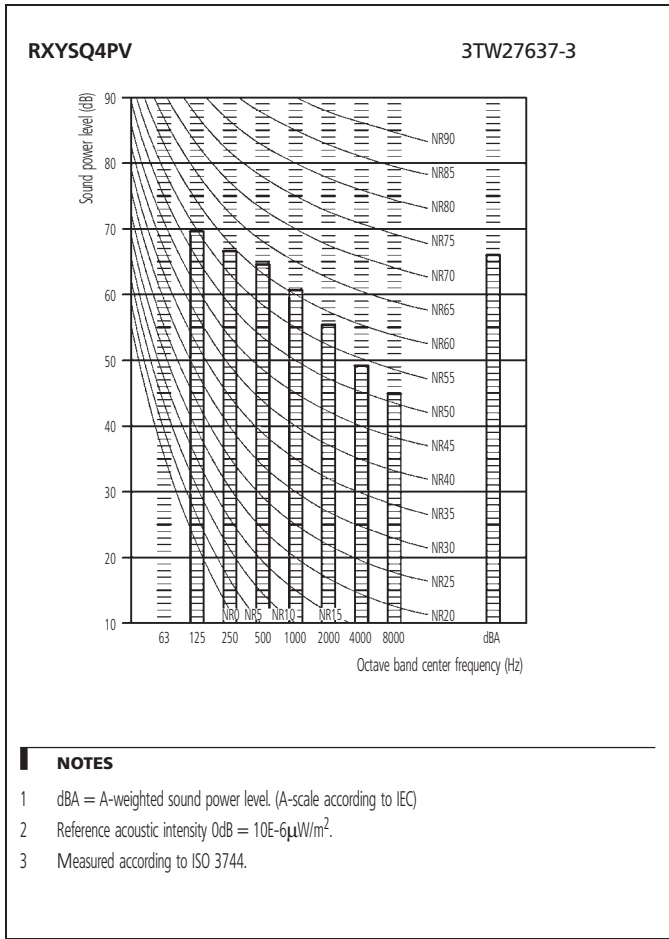

8 Installation

8 - 1 Service space

RXYSQ-PV

Required installation space

The unit of the values is mm.

1. Where there is an obstacle on the suction side

(a) No obstacle above

1 Stand-alone installation

- Obstacle on the suction side only.

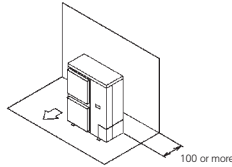

- Obstacle on both sides.

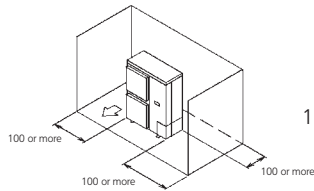

2 Series installation (2 or more).

- Obstacle on both sides

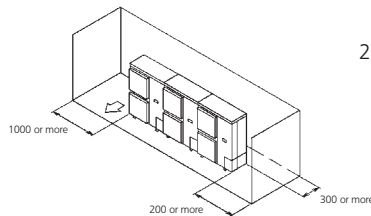

(b) Obstacle above, too.

1 Stand-alone installation

- Obstacle on the suction side,

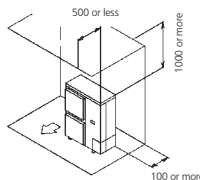

- Obstacle on the suction side and both sides.

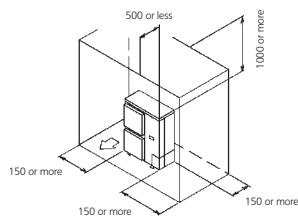

2 Series installation (2 or more).

- Obstacle on the suction side and both sides.

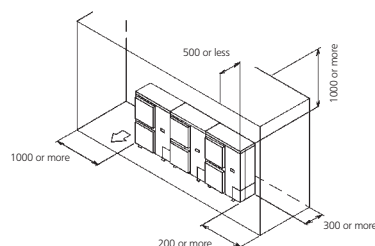

(2) Where there is an obstacle on the discharge side

(a) No obstacle above

(1) Stand-alone installation

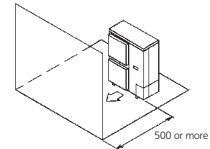

(2) Series installation (2 or more)

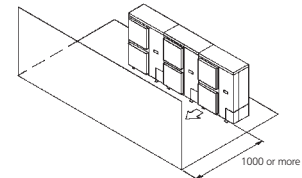

(b) Obstacle above, too.

1 Stand-alone installation

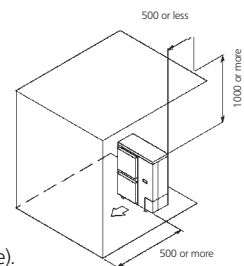

2 Series installation (2 or more).

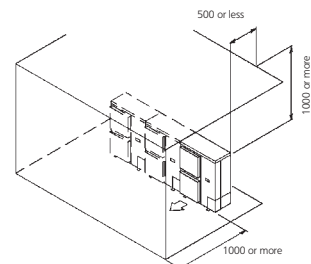

3. Where there are obstacles on both suction and discharge sides:

Pattern 1

Where the obstacles on the discharge side is higher than the unit.
(There is no height limit for obstructions on the intake side.)

(a) No obstacle above.

1 Stand-alone installation.

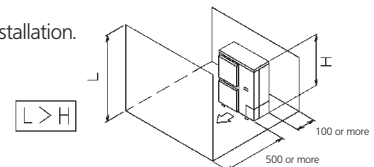

2 Series installation (2 or more).

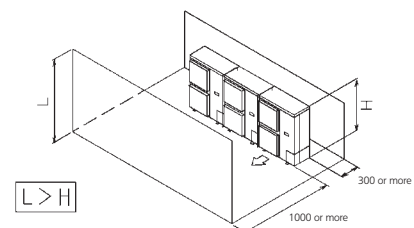

3D045696C

8 Installation

8 - 1 Service space

RXYSQ-PV

(b) Obstacle above, too

1 Stand-alone installation.

The relations between H, A and L are as follows.

	L	A
$L \leq H$	$0 < L \leq 1/2 H$	750
	$1/2 H < L \leq H$	1000
$H < L$	Set the stand as : $L \leq H$	

Close the bottom of the installation frame to prevent the discharged air from being bypassed.

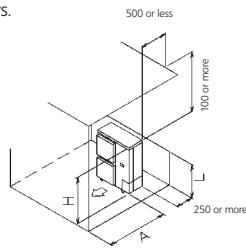

2 Series installation (2 or more).

The relations between H, A and L are as follows.

	L	A
$L \leq H$	$0 < L \leq 1/2 H$	1000
	$1/2 H < L \leq H$	1250
$H < L$	Set the stand as : $L \leq H$	

Close the bottom of the installation frame to prevent the discharged air from being bypassed.

Only two units can be installed for this series.

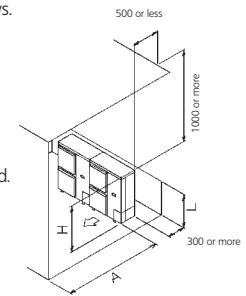

Pattern 2

Where the obstacle on the discharge side is lower than the unit.
(There is no height limit for obstructions on the intake side.)

(a) No obstacle above.

1 Stand-alone installation.

$$L \leq H$$

2 Series installation (2 or more).

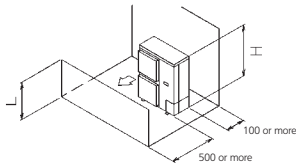

The relations between H, A and L are as follows.

	L	A
$L \leq H$	$0 < L \leq 1/2 H$	250
	$1/2 H < L \leq H$	300

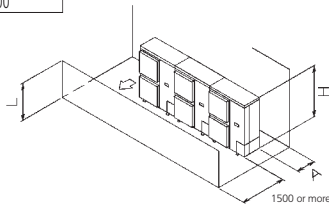

(b) Obstacle above, too.

1 Stand-alone installation.

The relations between H, A and L are as follows.

	L	A
$L \leq H$	$0 < L \leq 1/2 H$	100
	$1/2 H < L \leq H$	200
$H < L$	Set the stand as : $L \leq H$	

Close the bottom of the installation frame to prevent the discharged air from being bypassed.

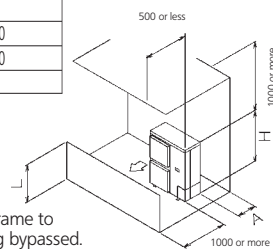

1 Series installation.

The relations between H, A and L are as follows.

	L	A
$L \leq H$	$0 < L \leq 1/2 H$	250
	$1/2 H < L \leq H$	300
$H < L$	Set the stand as : $L \leq H$	

Close the bottom of the installation frame to prevent the discharged air from being bypassed.

Only two units can be installed for this series.

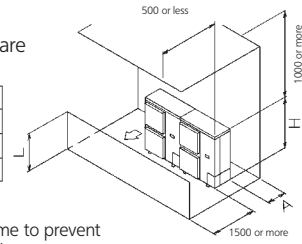

4. Double-decker installation

(a) Obstacle on the discharge side.

Close the gap A (the gap between the upper and lower outdoor units) to prevent the discharged air from being bypassed.

Do not stack more than two unit.

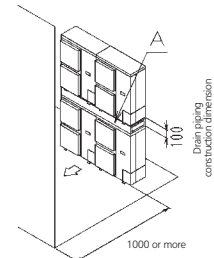

(b) Obstacle on the suction side only.

Close the gap A (the gap between the upper and lower outdoor units) to prevent the discharged air from being bypassed.

Do not stack more than one unit.

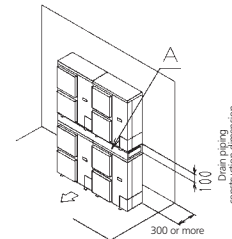

5. Multiple rows of series installation (on the rooftop, etc.)

(a) One row of stand-alone installation.

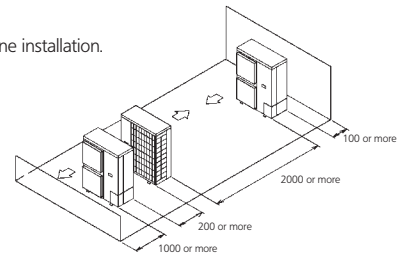

(b) Rows of series installation (2 or more).

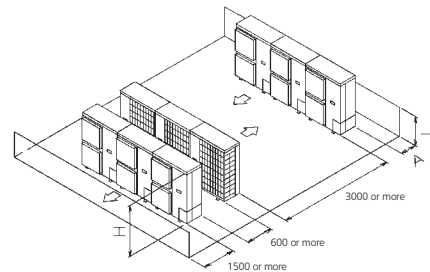

The relations between H, A and L are as follows.

	L	A
$L \leq H$	$0 < L \leq 1/2 H$	250
	$1/2 H < L \leq H$	300
$H < L$	Cannot be installed	

3D045696C

9 Operation range

RXYSQ-PV

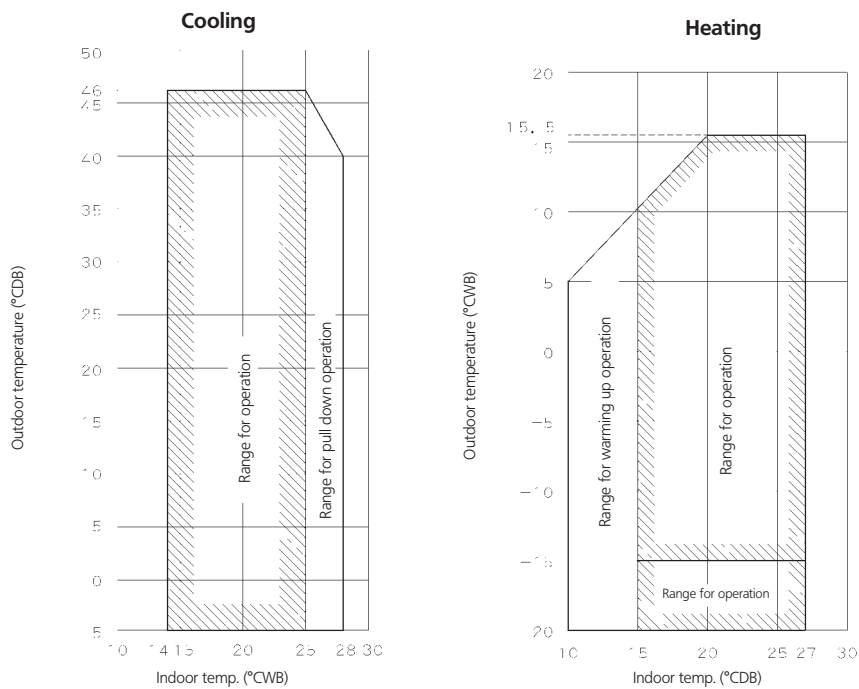

Notes:

These figures assume the following operating conditions.

- Indoor and outdoor units:
- Equivalent piping length
 - Level difference

7.5m
0m

3D045713C



Daikin's unique position as a manufacturer of air conditioning equipment, compressors and refrigerants has led to its close involvement in environmental issues. For several years Daikin has had the intention to become a leader in the provision of products that have limited impact on the environment. This challenge demands the eco design and development of a wide range of products and an energy management system, resulting in energy conservation and a reduction of waste.

VRV® products are not within the scope of the Eurovent certification programme.



The present publication is drawn up by way of information only and does not constitute an offer binding upon Daikin Europe N.V. Daikin Europe N.V. has compiled the content of this publication to the best of its knowledge. No express or implied warranty is given for the completeness, accuracy, reliability or fitness for particular purpose of its content and the products and services presented therein. Specifications are subject to change without prior notice. Daikin Europe N.V. explicitly rejects any liability for any direct or indirect damage, in the broadest sense, arising from or related to the use and/or interpretation of this publication. All content is copyrighted by Daikin Europe N.V.

Daikin products are distributed by:

